

LIGHT OAK RATTAN EFFECT SANTANA 3' BED ASSEMBLY INSTRUCTIONS

56359

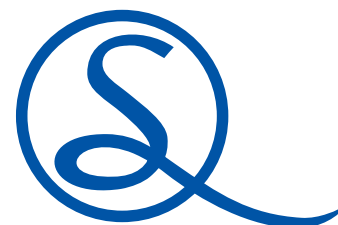

**MAX BED
WEIGHT**



FOR DOMESTIC USE ONLY

IMPORTANT

PLEASE READ BEFORE YOU CONTINUE FURTHER

CARE AND MAINTENANCE

After unpacking this product please keep the original packaging in case it needs to be returned for any reason.

- Please ensure all fittings and parts are present before commencing with assembly.
- We recommend that you lay a blanket or sheet on the floor to avoid damage to both your floor and the product.
- We strongly recommend that you keep children away from your work area.
- Assemble this product as close to its final position as possible.
- Never drag or push products as this could cause damage to the joints making it inferior.
- Do not place this product next to a radiator or in direct sunlight.
- Wood is a natural product and may expand if subjected to damp and may shrink or crack if subjected to heat. Therefore it is recommended that room temperature is maintained, with no sudden temperature fluctuations.
- Make sure any spillage is wiped off immediately.
- Do not place hot or chilled items directly on to the surface, use a place mat or marking will occur.
- For general cleaning use a duster, and do not use detergents of any kind. However, the surface will need to be retreated from time to time. This can be done by using block wax (unperfumed) and rubbing it over the whole item.
- From time to time it may be necessary to tighten fittings, regular inspections should be carried out.

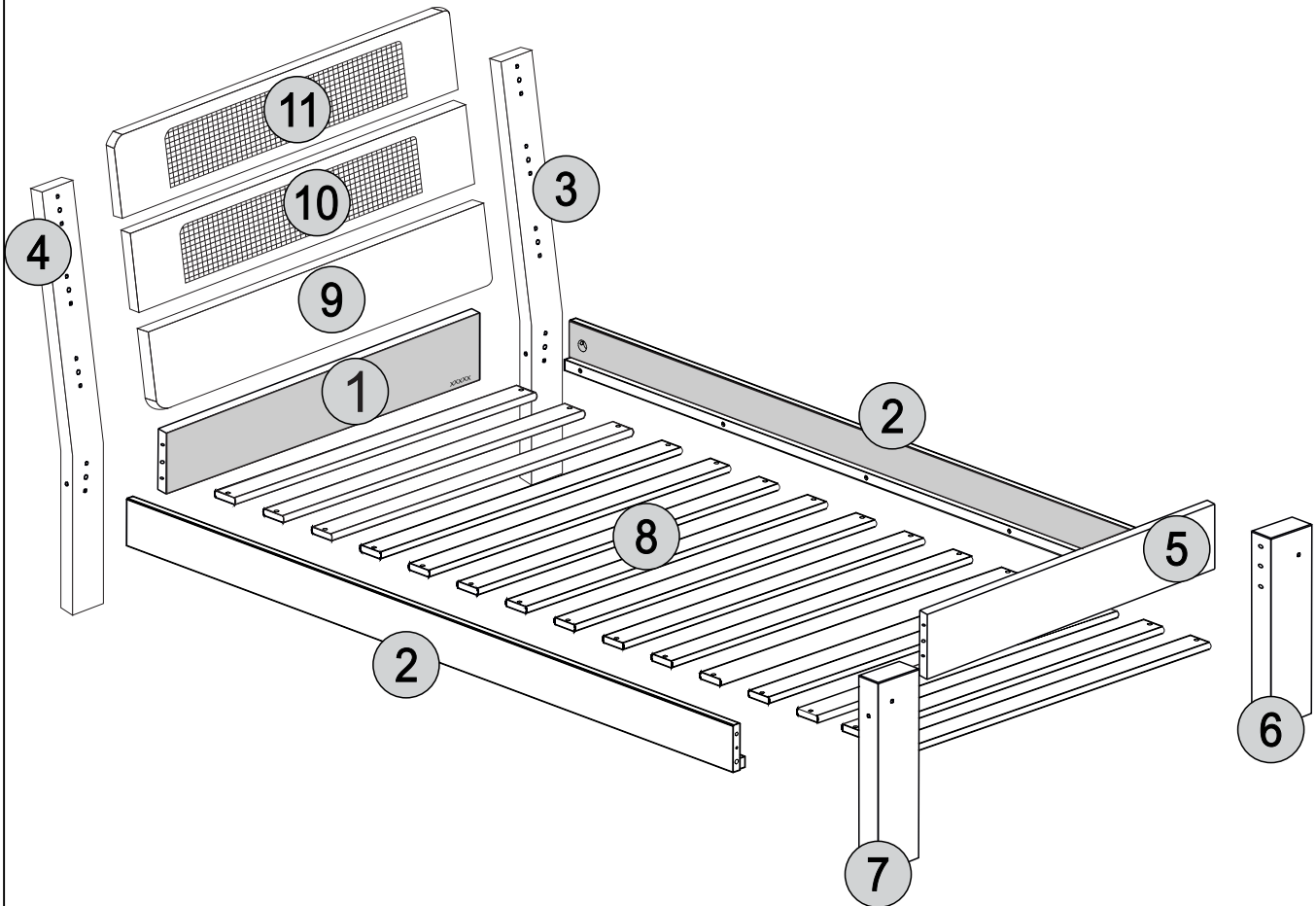

!
 * Use of power tools to assemble this product will invalidate any claim and damage this product making it unsafe !!!
 * Please assemble on a clean soft surface to avoid damage.

!
 * Please check contents and read the instructions before commencing assembly.
 * Assemble this product following the enclosed instructions carefully.
 * Please take care to avoid damaging panels during assembly.









PARTS LIST

Please Note:

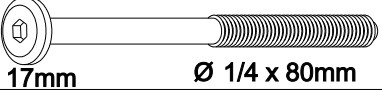
The below parts have all been stamped with the part number/color to help identify them during assembly.

Part Number	Part Code	Part Description	Quantity	Carton
1	S200-201-073-DC1-01	Headboard Panel	1	2/2
2	S200-201-073-DC1-02	Siderail	2	1/2
3	S200-201-073-DC1-03	Headboard Right Post (Natural)	1	2/2
4	S200-201-073-DC1-04	Headboard Left Post (Green)	1	2/2
5	S200-201-073-DC1-05	Footboard Panel	1	2/2
6	S200-201-073-DC1-06	Footboard Right Post	1	2/2
7	S200-201-073-DC1-07	Footboard Left Post (Green)	1	2/2
8	S200-201-073-DC1-08	Slats	13	2/2
9	S200-201-073-DC1-09	Lower Headboard Panel	1	2/2
10	S200-201-073-DC1-10	Centre Headboard Panel	1	2/2
11	S200-201-073-DC1-11	Top Headboard Panel	1	2/2

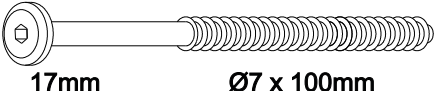
FITTINGS

A	 Ø8 x 50mm	16	F		01
B	 17mm Ø 1/4 x 80mm	04	G	 SPACER	02
C	 1/4	04	H	 Ø8 x 20mm	06
D	 17mm Ø7 x 100mm	04	I	 Ø5,0 x 50mm	12
E	 Ø4,0 x 30mm	26			

TOOLS REQUIRED

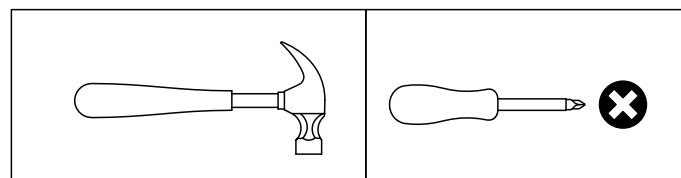

2,5m x 3m

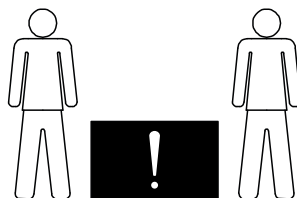
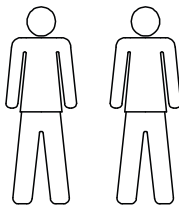

STEP 1

PARTS REQUIRED

1 - HEADBOARD PANEL	x1
2 - SIDERAIL	x2
5 - FOOTBOARD PANEL	x1

HARDWARE REQUIRED

A		16
---	---	----

TOOLS REQUIRED



Ø8 x 50mm



Ø8 x 20mm

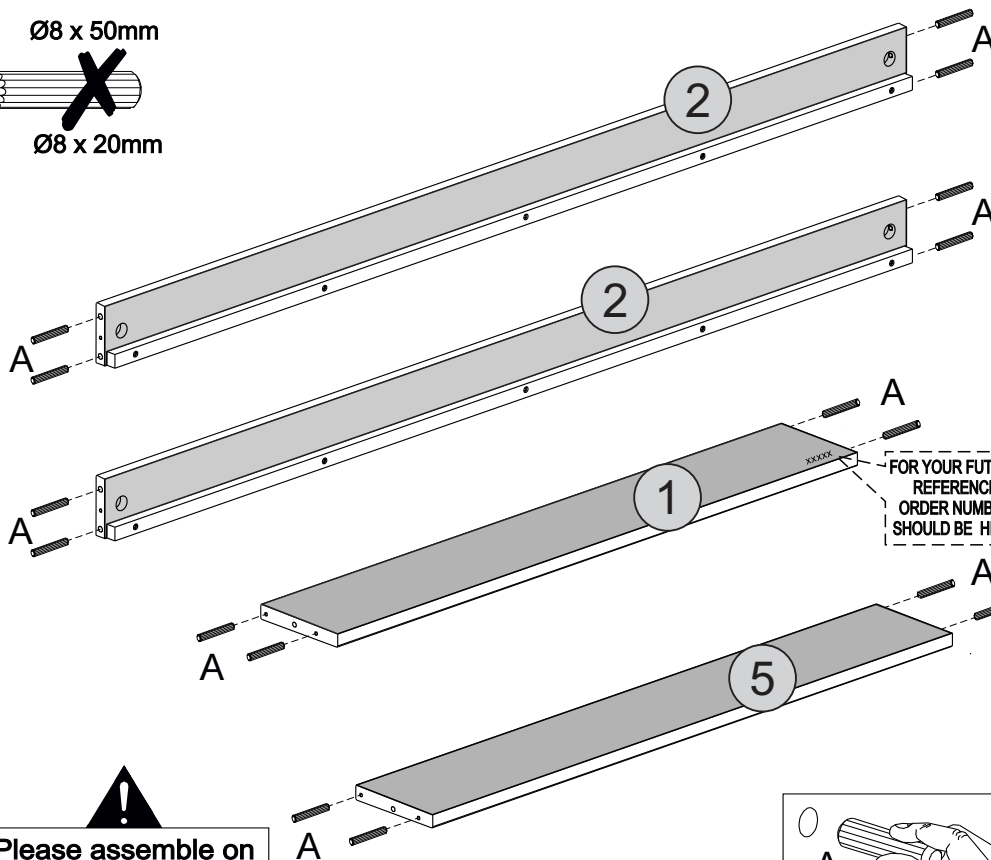

FOR YOUR FUTURE REFERENCE ORDER NUMBER SHOULD BE HERE

 Please assemble on a clean soft surface to avoid damage.

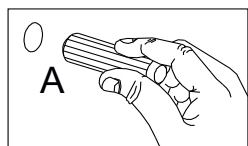

STEP 2

PARTS REQUIRED

3 - HEADBOARD RIGHT POST (NATURAL) X1
4 - HEADBOARD LEFT POST (GREEN) X1

HARDWARE REQUIRED

H		06
---	---	----

TOOLS REQUIRED



Ø8 x 50mm

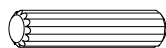

Ø8 x 20mm

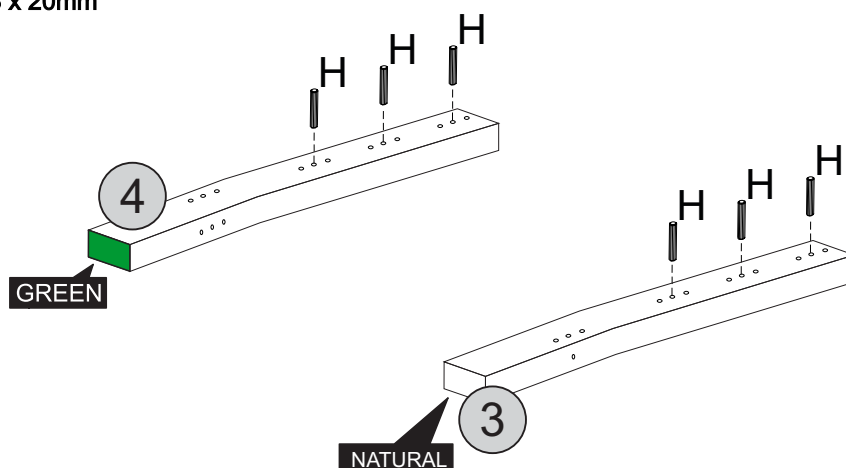

 Please assemble on a clean soft surface to avoid damage.

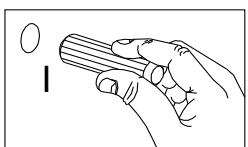

STEP 3

PARTS REQUIRED

- 1 - HEADBOARD PANEL x1
- 3 - HEADBOARD RIGHT POST (NATURAL) x1
- 4 - HEADBOARD LEFT POST (GREEN) x1

HARDWARE REQUIRED

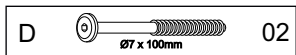

TOOLS REQUIRED

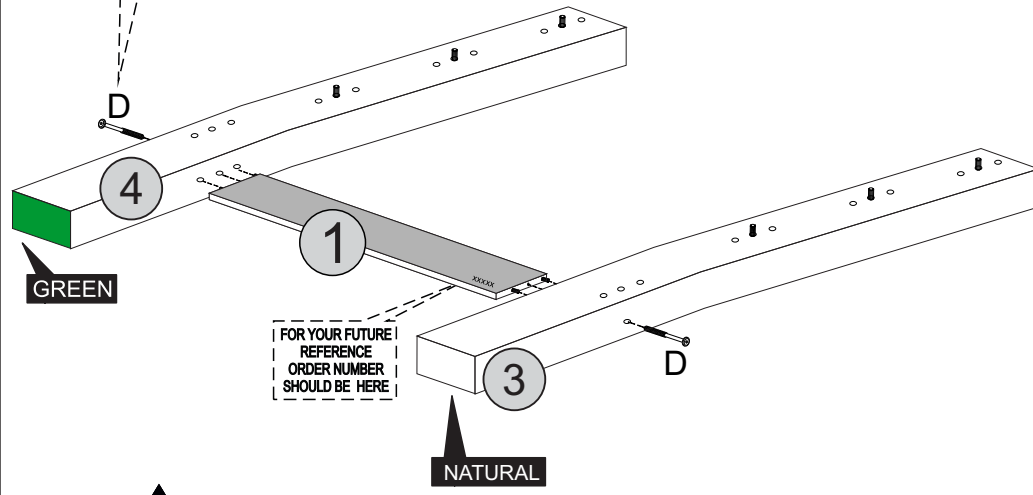
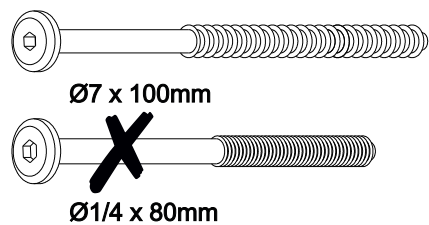
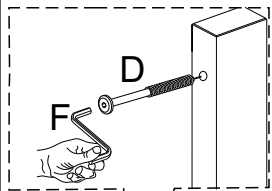
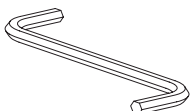

Please assemble on a clean soft surface to avoid damage.

STEP 4

PARTS REQUIRED

- 10 - CENTRE HEADBOARD PANEL x1
- 11 - TOP HEADBOARD PANEL x1

HARDWARE REQUIRED

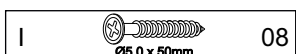

TOOLS REQUIRED

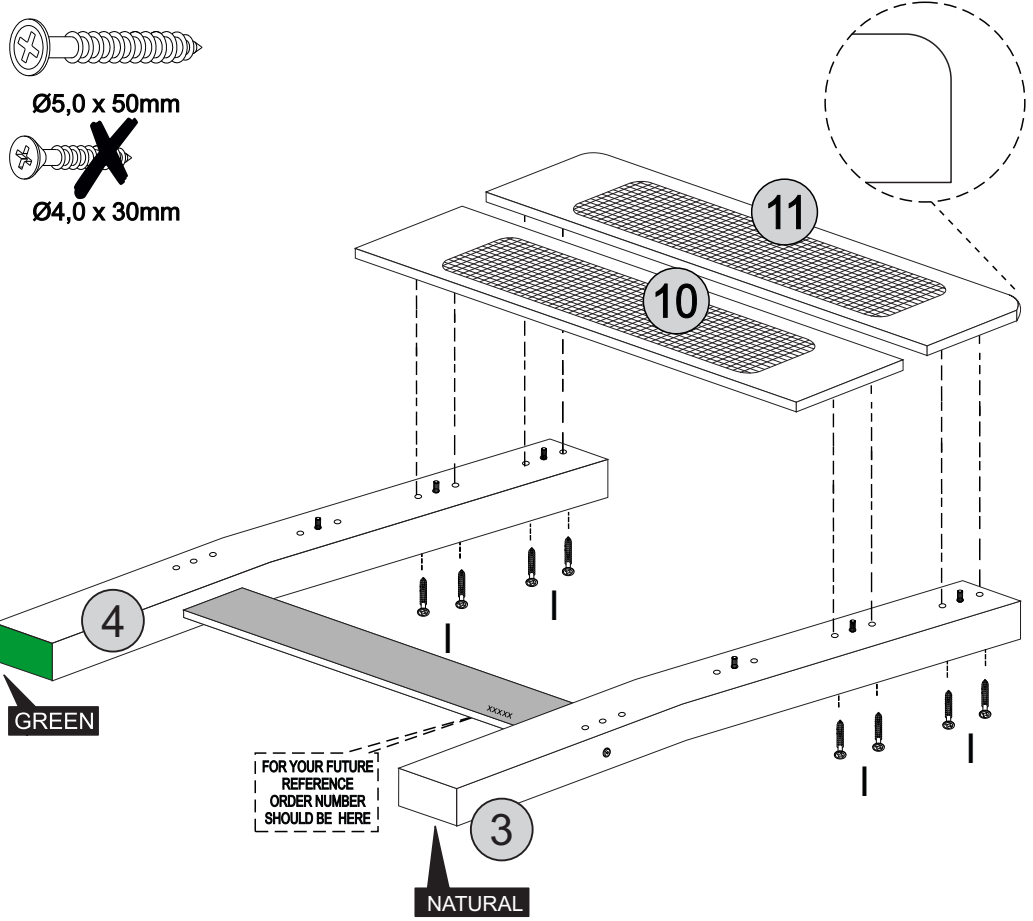
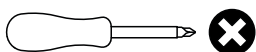

STEP 5

PARTS REQUIRED

9 - LOWER HEADBOARD PANEL x1

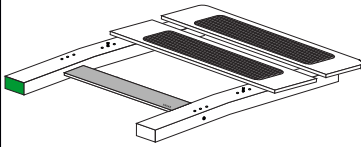

HARDWARE REQUIRED

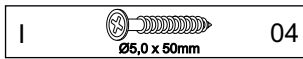

TOOLS REQUIRED

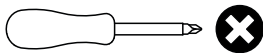

Ø5,0 x 50mm



Ø4,0 x 30mm

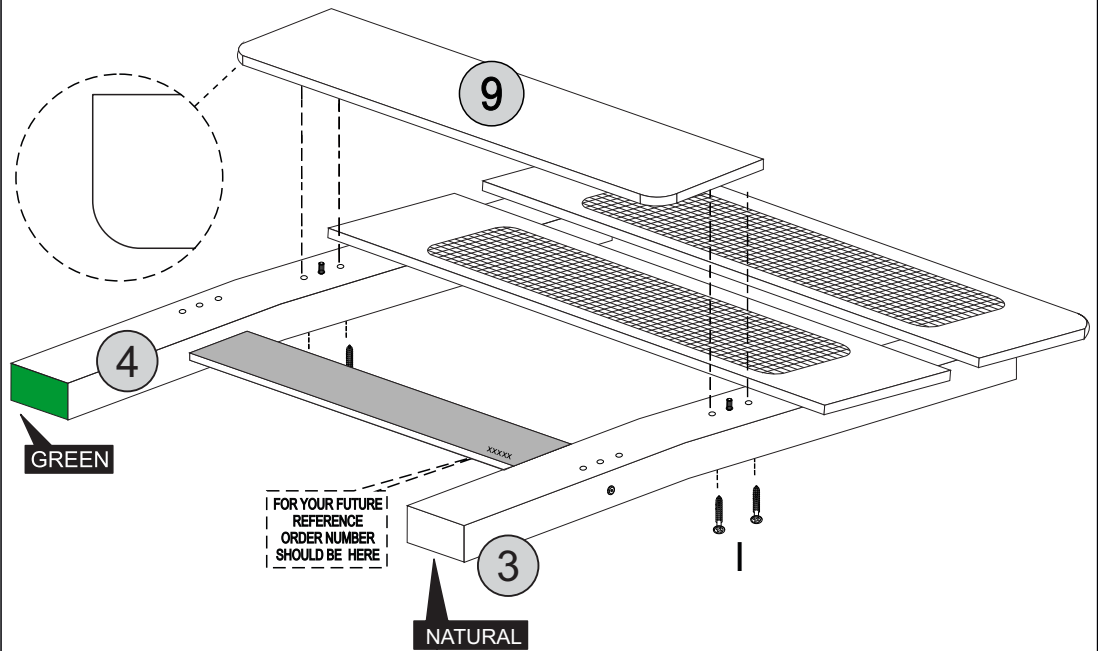

STEP 6

PARTS REQUIRED

5 - FOOTBOARD PANEL x1

6 - FOOTBOARD RIGHT POST (NATURAL) x1

7 - FOOTBOARD LEFT POST (GREEN) x1

HARDWARE REQUIRED

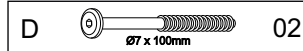

TOOLS REQUIRED

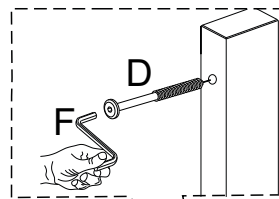
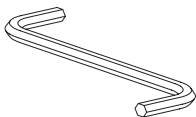

Ø7 x 100mm

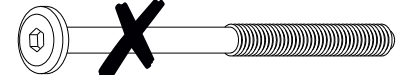

Ø1/4 x 80mm

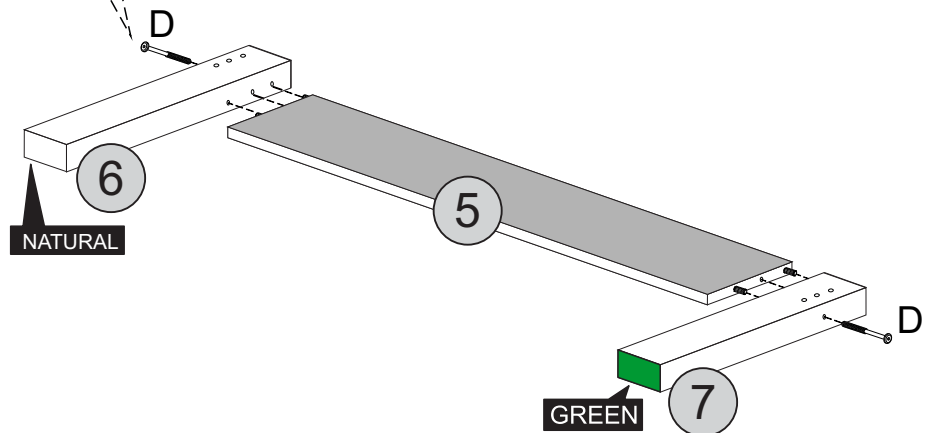

!
Please assemble on a clean soft surface to avoid damage.

STEP 7

PARTS REQUIRED

2- SIDERAIL x2

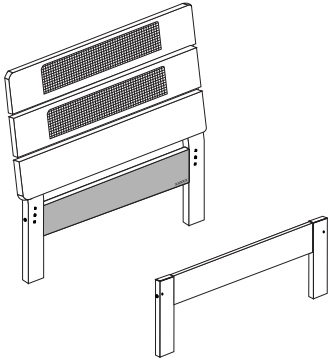

HARDWARE REQUIRED

B  Ø1/4 x 80mm 04

C  1/4 04

TOOLS REQUIRED

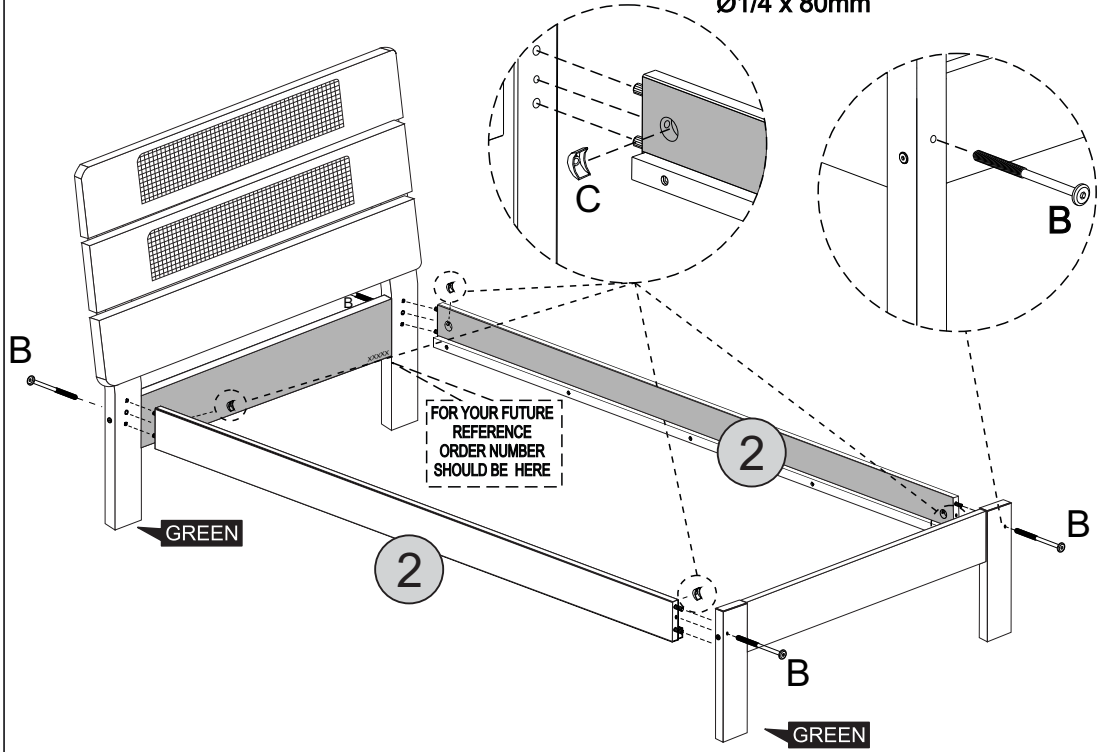
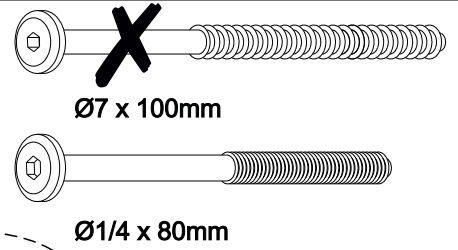
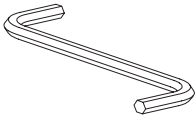

STEP 8

PARTS REQUIRED

8 - SLATS x13

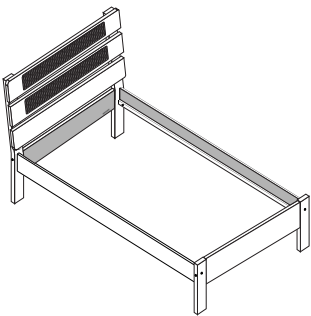

HARDWARE REQUIRED

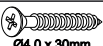
E  Ø4,0 x 30mm 26

G  SPACER 02

TOOLS REQUIRED

