

CORONA 5' HIGH END BED ASSEMBLY INSTRUCTIONS

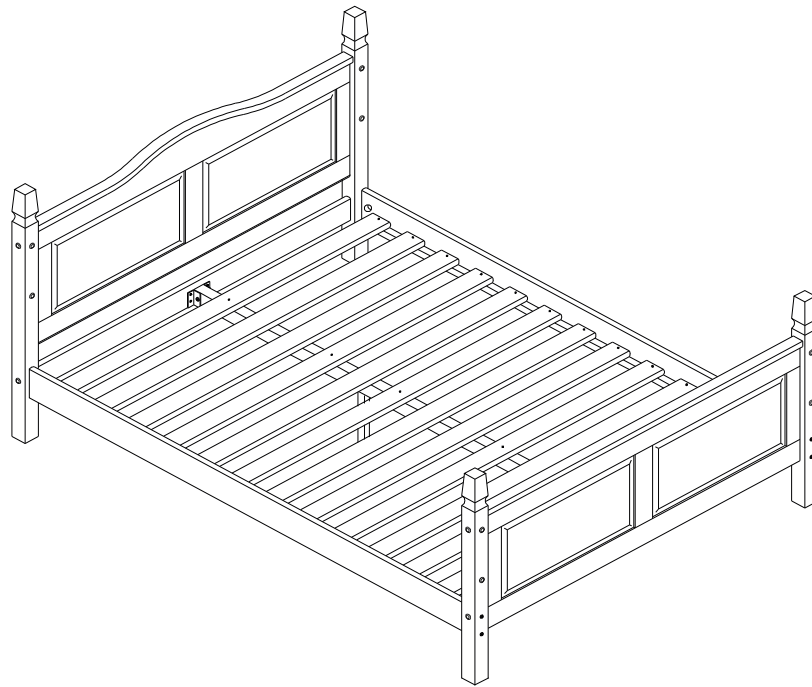
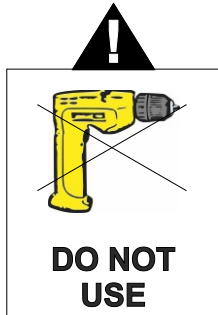

IMPORTANT
PLEASE READ BEFORE YOU CONTINUE FURTHER
FOR DOMESTIC USE ONLY
CARE AND MAINTENANCE

After unpacking this product please keep the original packaging in case it needs to be returned for any reason.

- Please ensure all fittings and parts are present before commencing with assembly.
- We recommend that you lay a blanket or sheet on the floor to avoid damage to both your floor and the product.
- We strongly recommend that you keep children away from your work area.
- Assemble this product as close to its final position as possible.
- Never drag or push products as this could cause damage to the joints making it inferior.
- Do not place this product next to a radiator or in direct sunlight.
- Wood is a natural product and may expand if subjected to damp and may shrink or crack if subjected to heat. Therefore it is recommended that room temperature is maintained, with no sudden temperature fluctuations.
- Make sure any spillage is wiped off immediately.
- Do not place hot or chilled items directly on to the surface, use a place mat or marking will occur.
- For general cleaning use a duster, and do not use detergents of any kind. However, the surface will need to be retreated from time to time. This can be done by using block wax (unperfumed) and rubbing it over the whole item.
- From time to time it may be necessary to tighten fittings, regular inspections should be carried out.

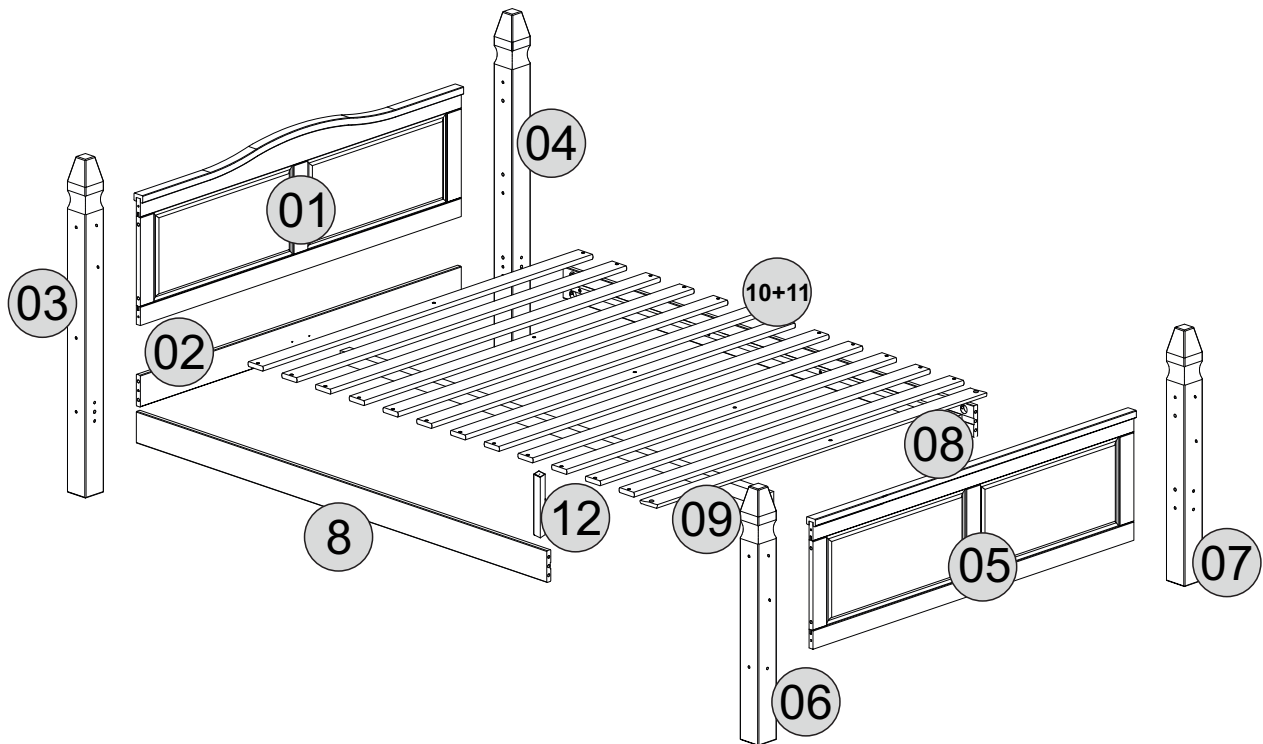

!

- * Use of power tools to assemble this product will invalidate any claim and damage this product making it unsafe !!!
- * Please assemble on a clean soft surface to avoid damage.







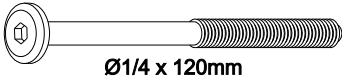

!

- * Please check contents and read the instructions before commencing assembly.
- * Assemble this product following the enclosed instructions carefully.
- * Please take care to avoid damaging panels during assembly.

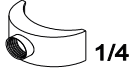
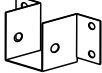
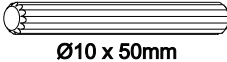
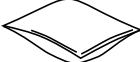
PARTS LIST

Part Number	Part Code	Part Description	Quantity	Carton
1	S200-203-009-LT1-01	Headboard Panel	1	1/4
2	S200-203-009-LT1-02	Crossbeam	1	3/4
3	S200-203-009-LT1-03	Left Headboard Post	1	2/4
4	S200-203-009-LT1-04	Right Headboard Post	1	2/4
5	S200-203-009-LT1-05	Footboard Panel	1	1/4
6	S200-203-009-LT1-06	Left Footboard Post	1	2/4
7	S200-203-009-LT1-07	Right Footboard Post	1	2/4
8	S200-203-009-LT1-08	Side Rail	2	3/4
9	S200-203-009-LT1-09	Centre Support Rail	1	3/4
10	S200-203-009-LT1-10	Slats (2 holes)	8	4/4
11	S200-203-009-LT1-11	Slats (3 holes)	5	4/4
12	S200-203-009-LT1-12	Centre Support Leg	1	2/4

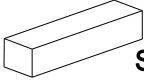
FITTINGS

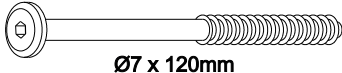
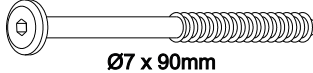
A	 Ø1/4 x 120mm	08	H	 Ø4.0 x 16mm	08
B	 1/4	08	I		02
C	 Ø10 x 50mm	12	J		02
D	 Ø3,5 x 30mm	31	K	 Ø1/4 x 60mm	02
E		01	L		08
F	 SPACER	02	M	 Ø12 x 40mm	04
G	 Ø7 x 120mm	10	N	 Ø7 x 90mm	01

TOOLS REQUIRED

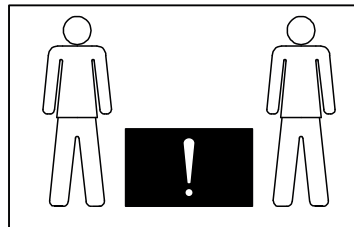
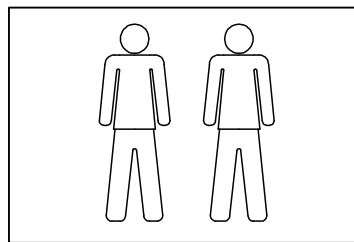
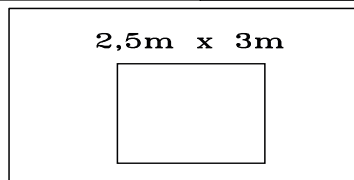
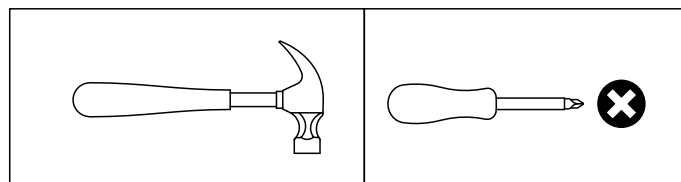

STEP 1

PARTS REQUIRED

08 - SIDERAIL x2

HARDWARE REQUIRED

M  04
Ø12 x 40mm

TOOLS REQUIRED

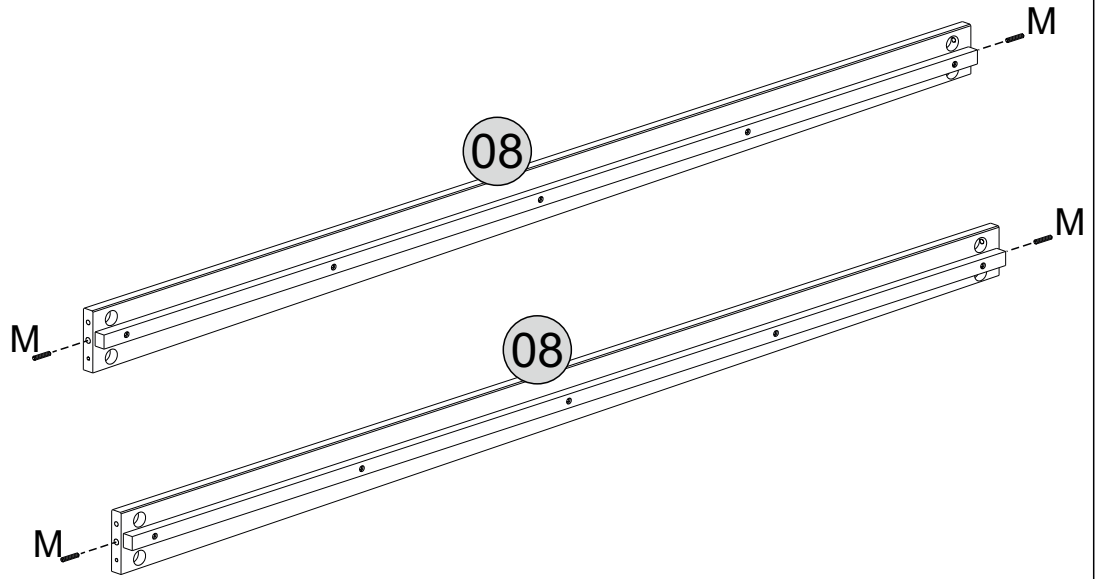

 Please assemble on a clean soft surface to avoid damage.

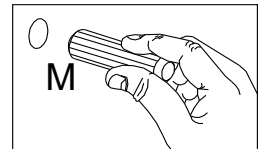

STEP 2

PARTS REQUIRED

01 - HEADBOARD PANEL x1

02 - CROSSBEAM x1

HARDWARE REQUIRED

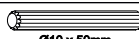
C  08
Ø10 x 50mm

J  01

TOOLS REQUIRED

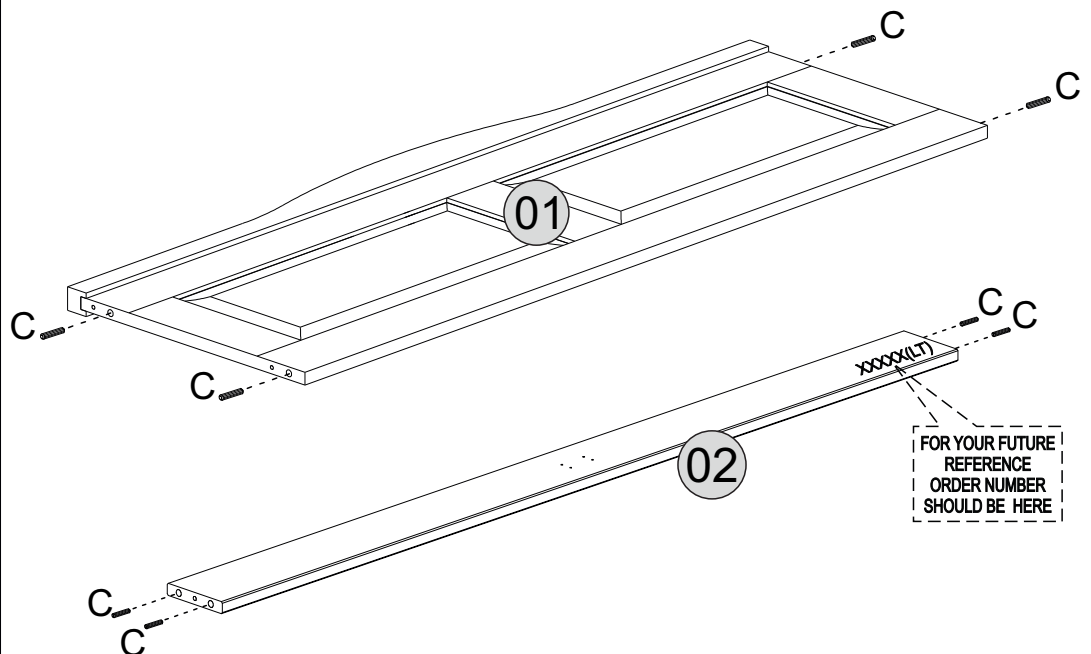

 Please assemble on a clean soft surface to avoid damage.

 Glue must be added to the dowel holes on parts 1 and 7.

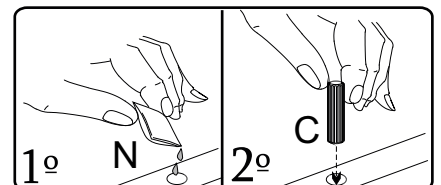

STEP 3

PARTS REQUIRED

05 - FOOTBOARD PANEL x1

HARDWARE REQUIRED

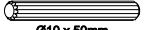
C  04
Ø10 x 50mm

J  01

TOOLS REQUIRED

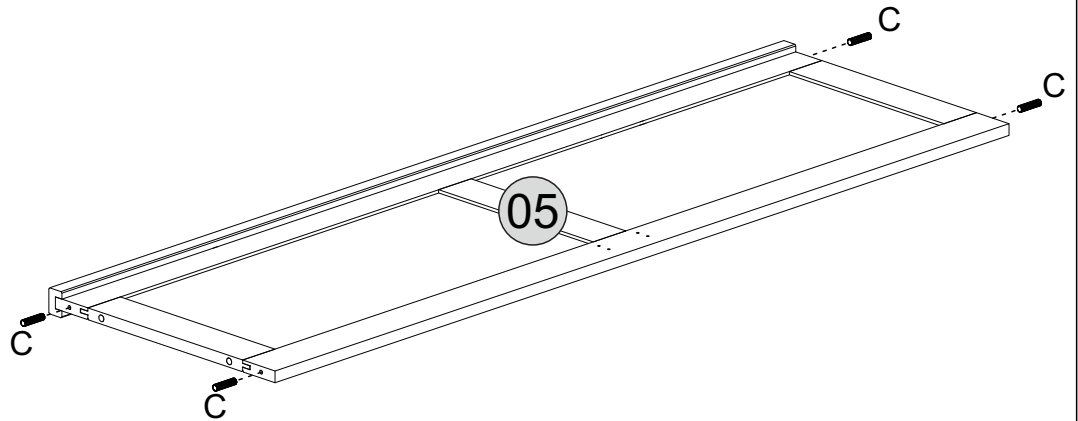

 Please assemble on a clean soft surface to avoid damage.

 Glue must be added to the dowel holes on part 05.

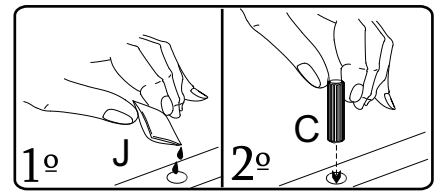

STEP 4

PARTS REQUIRED

01 - HEADBOARD PANEL x1

02 - HEADBOARD CROSSBEAMx1

03 - HEADBOARD RIGHT POST x1

04 - HEADBOARD LEFT POST x1

HARDWARE REQUIRED

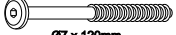
G  06
Ø7 x 120mm

J  01

TOOLS REQUIRED

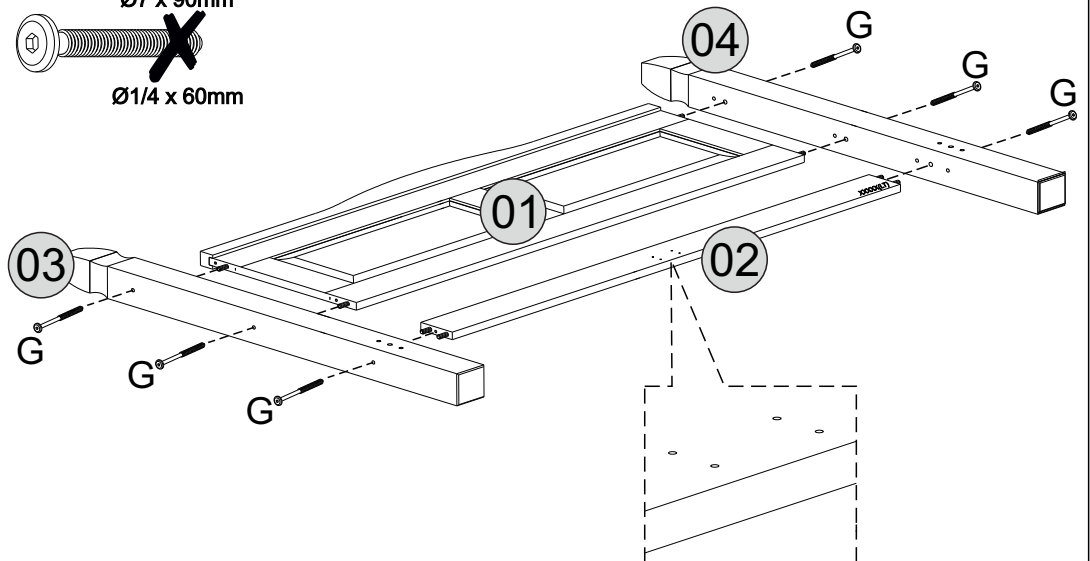
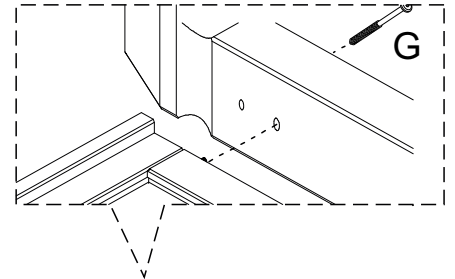
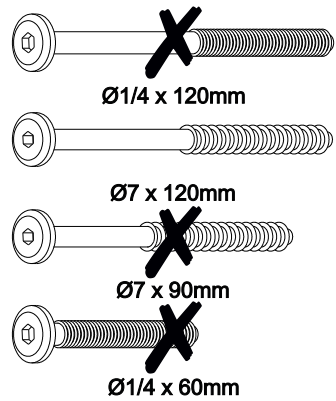
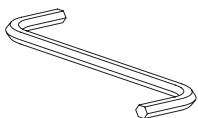

 Please assemble on a clean soft surface to avoid damage.

 Glue must be added to the dowel holes on part 03 and 04.

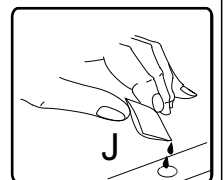



STEP 5

PARTS REQUIRED

- 5 - FOOTBOARD PANEL x1
- 6 - LEFT FOOTBOARD POST x1
- 7 - RIGHT FOOTBOARD POST x1

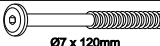
HARDWARE REQUIRED

- G  04
Ø7 x 120mm
- J  01

TOOLS REQUIRED

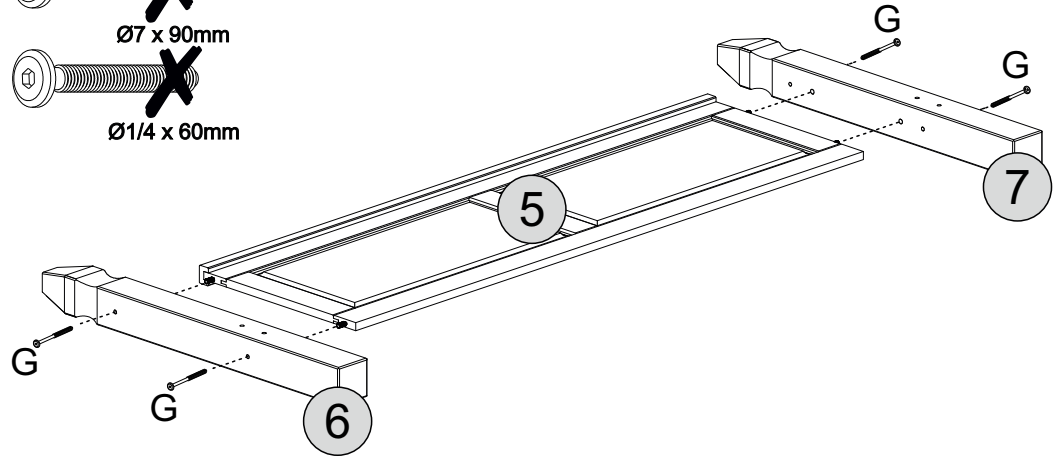
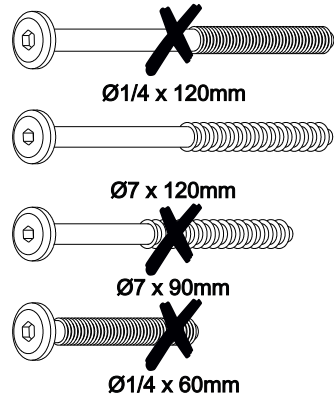
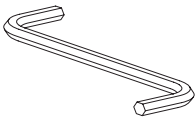

!
Please assemble on a clean soft surface to avoid damage.

!
Glue must be added to the dowel holes on part 6 and 7.

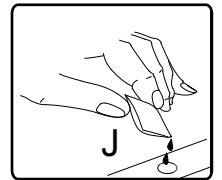



STEP 6

PARTS REQUIRED

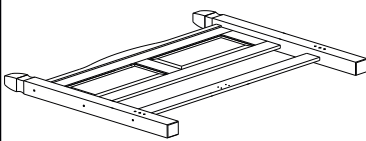
- 8 - SIDERAIL x2

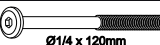

HARDWARE REQUIRED

- A  04
Ø1/4 x 120mm
- B  04
1/4

TOOLS REQUIRED

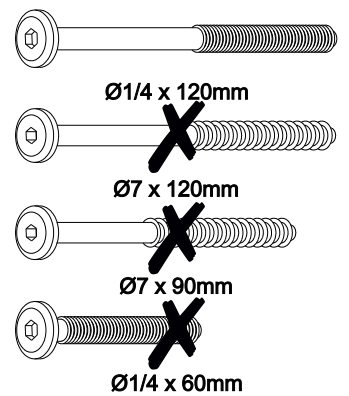
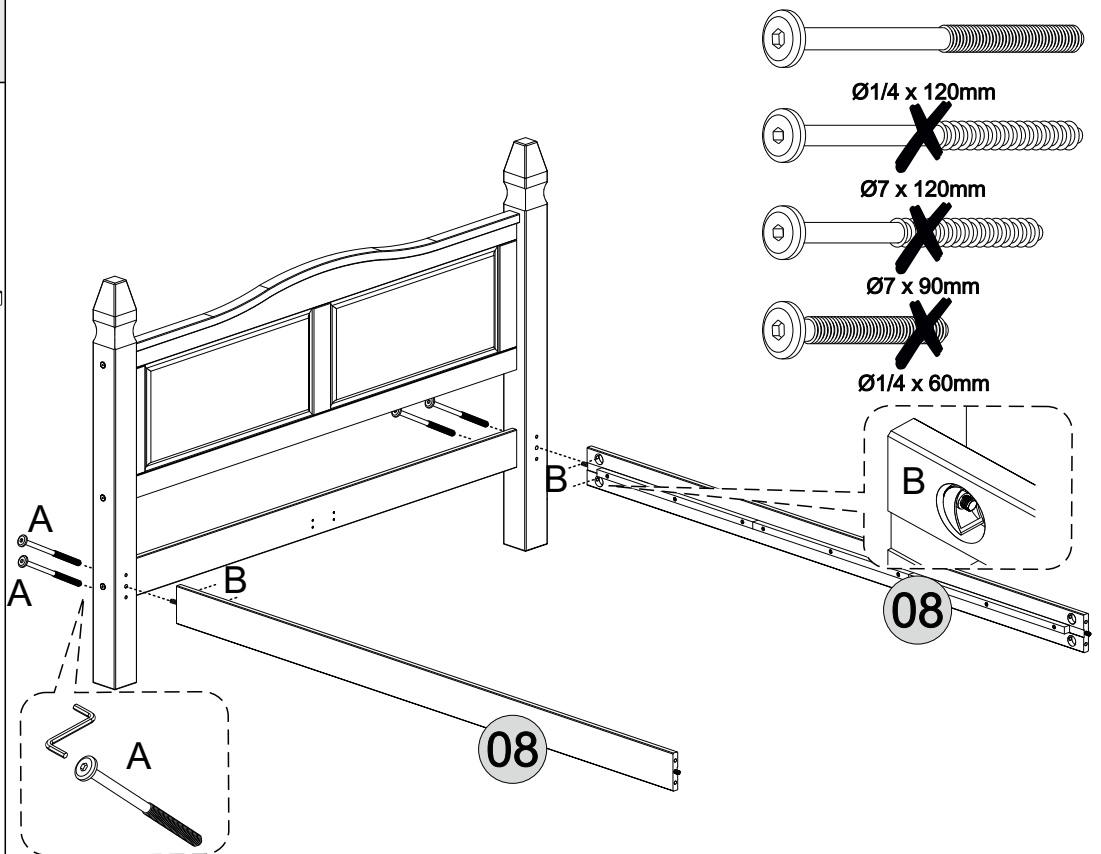
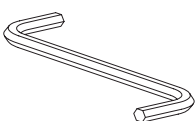



!
Please assemble on a clean soft surface to avoid damage.

STEP 7

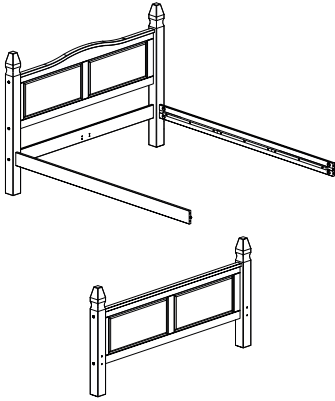
PARTS REQUIRED



HARDWARE REQUIRED

A	 Ø1/4 x 120mm	04
B	 1/4	04

TOOLS REQUIRED

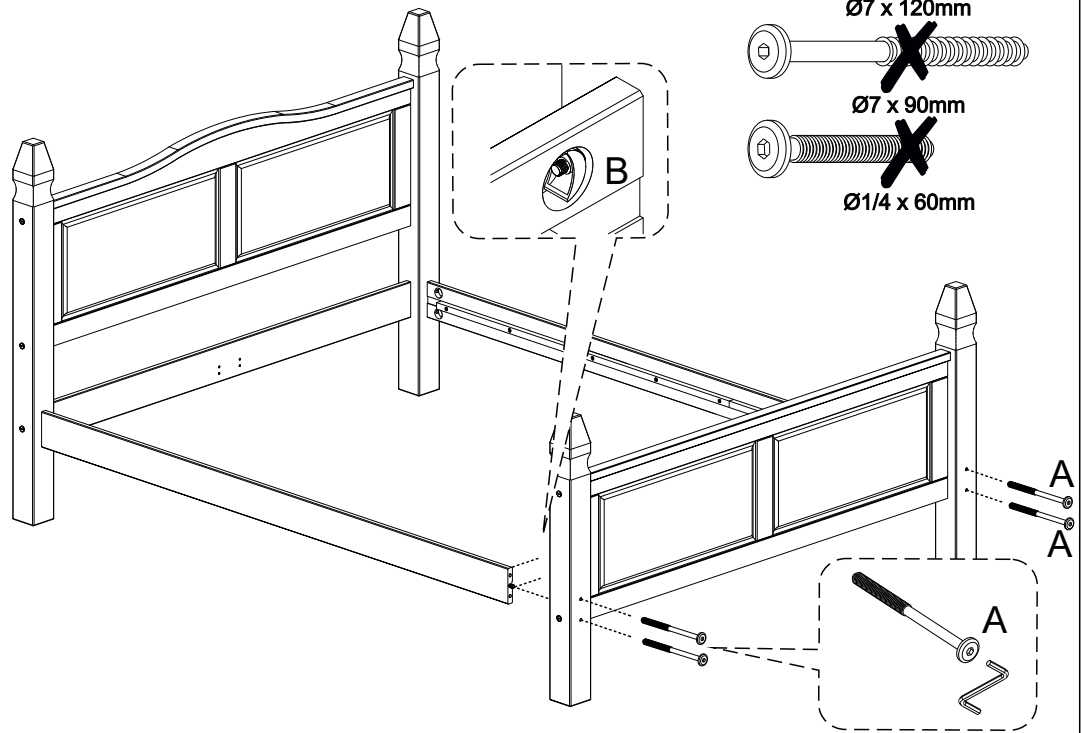
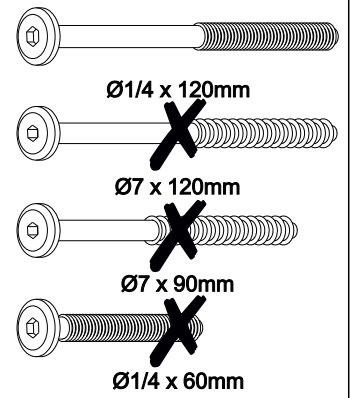
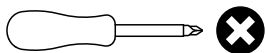

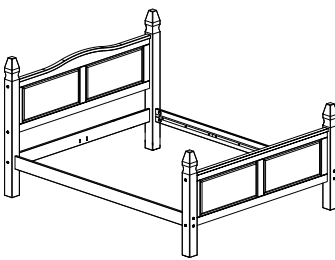

STEP 8

PARTS REQUIRED



HARDWARE REQUIRED

H	 Ø4.0 x 16mm	08
I		02

TOOLS REQUIRED

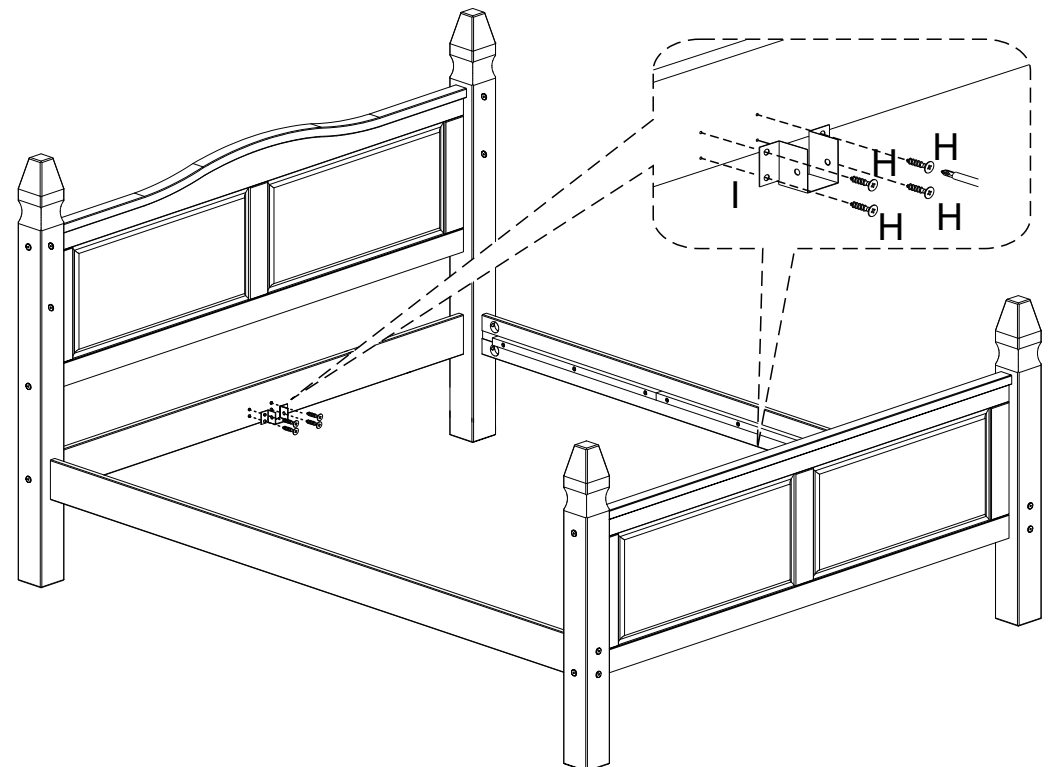
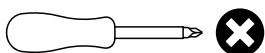

STEP 9

PARTS REQUIRED

09 - CENTRE SUPPORT RAIL x1

12 - CENTRE SUPPORT LEG x1

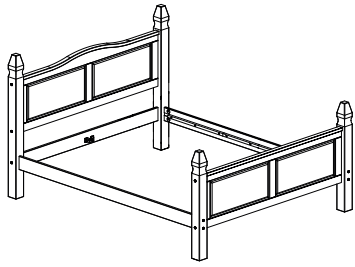

HARDWARE REQUIRED

K  02
Ø1/4 x 60mm

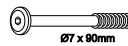
N  01
Ø7 x 90mm

TOOLS REQUIRED

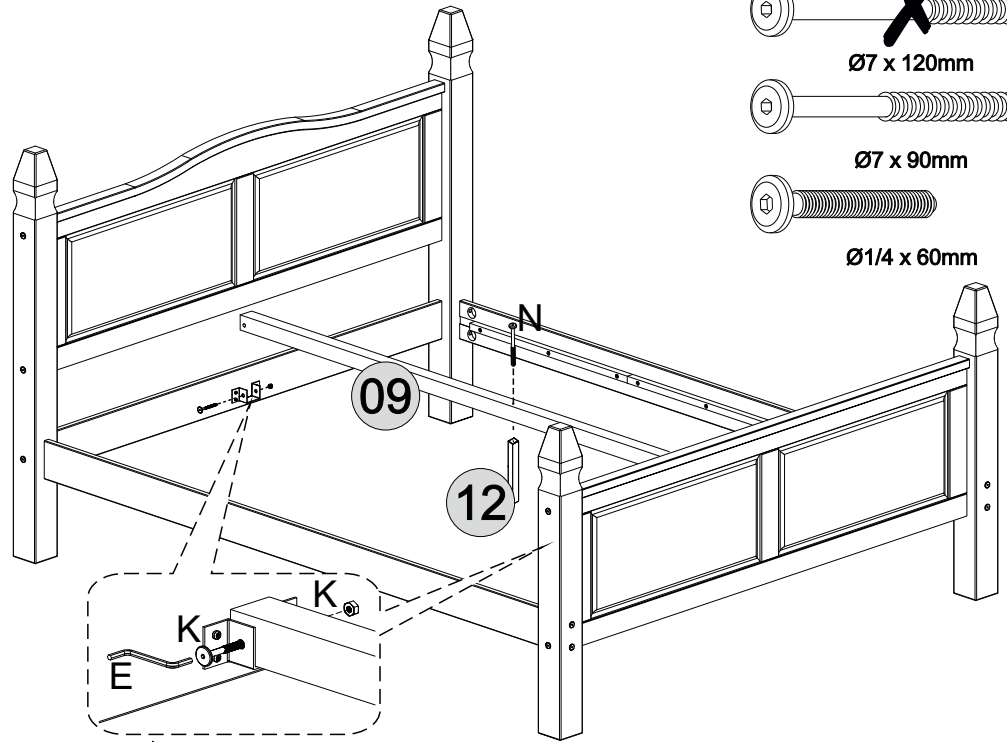
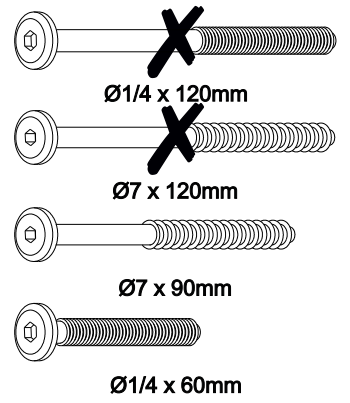
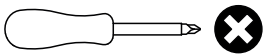

!
Please assemble on a clean soft surface to avoid damage.

STEP 10

PARTS REQUIRED

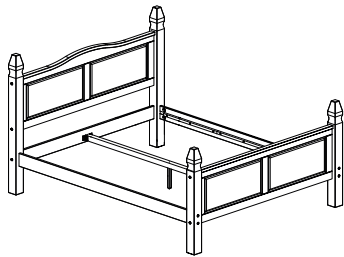

HARDWARE REQUIRED

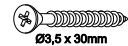
D  31
Ø3,5 x 30mm

F  02
SPACER

TOOLS REQUIRED

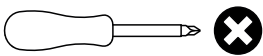

Please fix the first slats adjacent to the headboard and footboard and work towards the middle of the bed using the spacer (F) as shown to ensure correct spacing. Fix all the slats to one siderail first then push the second siderail tight against the slats and fix.

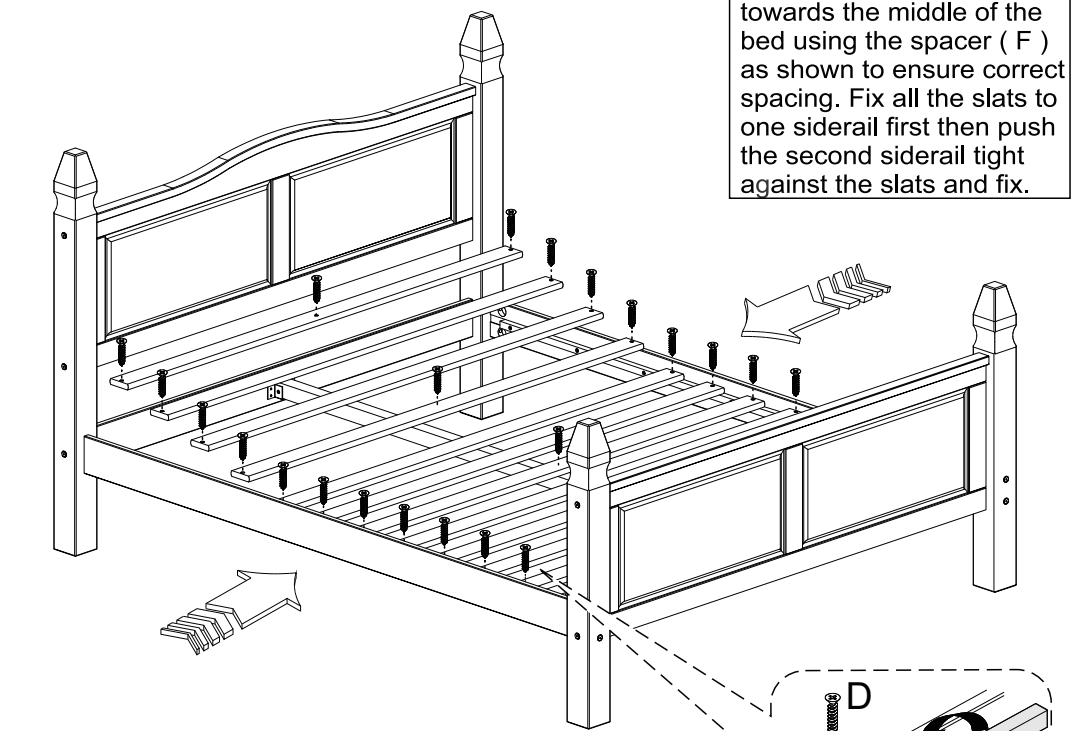

!
Please assemble on a clean soft surface to avoid damage.

STEP 11

PARTS REQUIRED

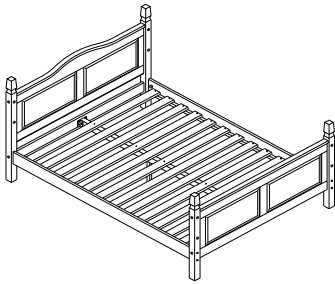

HARDWARE REQUIRED



TOOLS REQUIRED

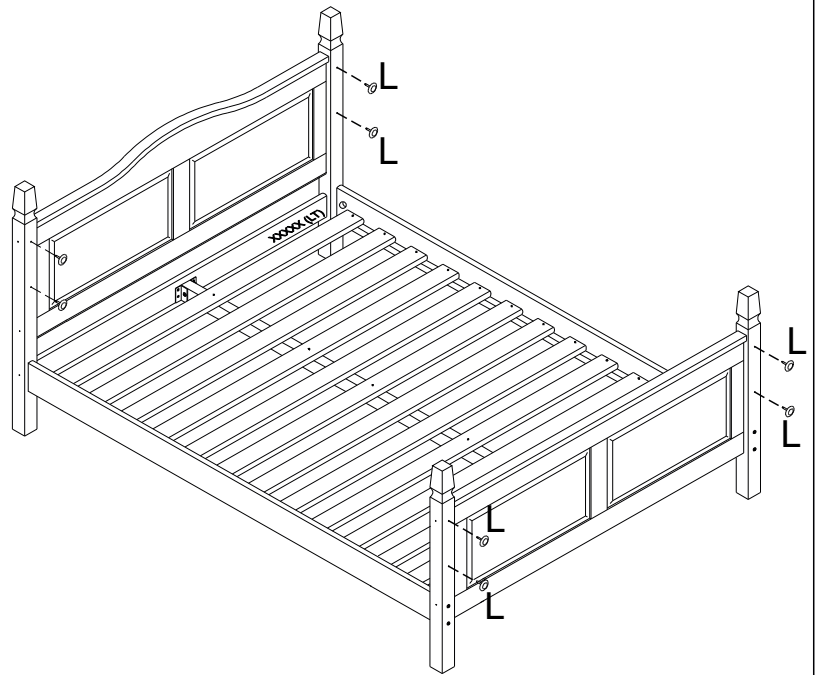
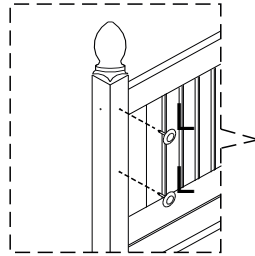

Please assemble on a clean soft surface to avoid damage.

STEP 12

PARTS REQUIRED

HARDWARE REQUIRED

TOOLS REQUIRED

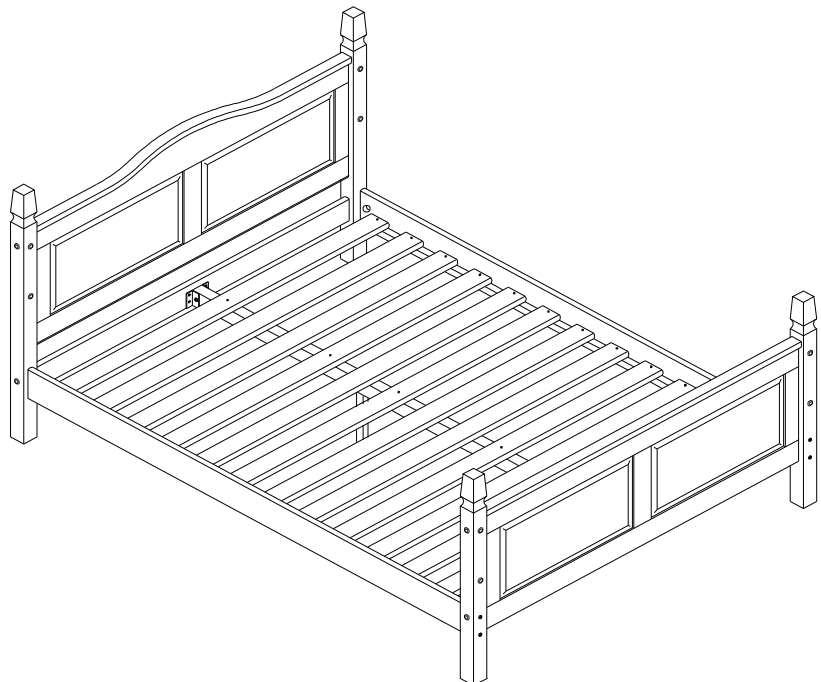

Please assemble on a clean soft surface to avoid damage.