

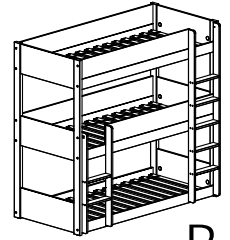















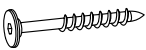

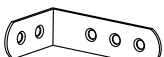

A

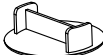

B

A		8x40	x80
B		7x60	x12
C		7x50	x28
D		D35	x12
E		M6x75	x16
F		M6x10x13	x16
G		6,3x70	x2
H		55/12,2x5	x14
J		3,5x40	x90
K		4,2x35	x2
L		20x42x70	x2

M		4x30	x4
N		7x34	x4
P		D15x13,5	x4
R		D4x13	x28
S		D8x13	x8
T		D15x18	x18
U		D35	x12
V		D4x17	x4
X		D13	x4
Y		D25x3	x4
Z		4mm	x1

D Montageanleitung

WICHTIG - AUFMERKSAM LESEN - ZUR SPATEREN EINSICHTNAHME AUFZUBEWAHREN

a) **WARNUNG** Hochbetten und das obere Bett bei Etagenbetten sind wegen des Verletzungsrisikos durch Stürze nicht für Kinder unter sechs Jahren geeignet.

b) **WARNUNG** Wenn sie nicht richtig verwendet werden, können Hochbetten und Etagenbetten ein schweres Verletzungsrisiko durch Strangulierung darstellen. Es dürfen niemals Elemente an Teilen des Hochbetts befestigt oder aufgehängt werden, die nicht zur Verwendung mit besagtem Bett bestimmt sind. Diese Elemente umfassen, sind aber nicht beschränkt auf, Seile, Fäden, Schnüre, Haken, Gürtel und Taschen.

c) **WARNUNG** Kinder können sich zwischen dem Bett und einer Wand, einer gekippten Wandstelle, der Decke, Möbeln in der Nähe (zum Beispiel Schränke) oder anderem einklemmen. Um jedes Risiko einer schweren Verletzung zu vermeiden, darf der Abstand zwischen der oberen Sicherheitsschranke und den Elementen in der Umgebung 75 mm nicht überschreiten oder muss größer als 230 mm sein.

d) **WARNUNG** Das Hochbett oder das Etagenbett darf nicht verwendet werden, wenn ein Teil des Aufbaus fehlt oder beschädigt ist. Ersatzteile müssen beim Hersteller oder im Laden bestellt werden.

e) Die Montage- und Gebrauchsanweisungen des Herstellers müssen unbedingt immer befolgt werden.

f) Die empfohlene Größe der mit dem Bett zu verwendenden Matratze beträgt 1900 mm x 900 mm. **Höchstdicke der Matratze: 164mm,**

g) Es ist notwendig, den Raum zu lüften, um einen geringen Feuchtigkeitsgrad aufrechtzuerhalten und die Entwicklung von Schimmel im Bett und seiner Umgebung zu verhindern.

k) Die Montagevorrichtungen müssen immer angemessen festgezogen und regelmäßig überprüft werden. Wenn nötig, erneut festziehen.

l) Entspricht den europäischen Sicherheitsanforderungen der Norm EN 747+A1 : 2015.

m) Wenn ein Nachtlicht vorhanden ist, kann dies dem im oberen Bett schlafenden Kind mehr Sicherheit geben.

EN Assembling instructions

IMPORTANT - READ CAREFULLY - KEEP FOR FUTURE REFERENCE

a) **WARNING** Raised beds and the upper bed in a bunk bed assembly are not good for children under 6 years old because of the risk of injury from falling from such beds,

b) **WARNING** If the raised and bunk beds are not used correctly, they can present a serious risk of injury from strangulation. Never attach or suspend things from the upper bunk bed that are not going to be used with that bed. Such things include - but are not limited to - cords, string, sashes, hooks, belts and bags.

c) **WARNING** Children can find themselves trapped between the bed and wall, or inclined roof wall, ceiling, adjacent pieces of furniture (such as cupboards) or other items. To avoid any risk of serious injury, the distance between the upper safety barrier and surrounding items should not exceed 75 mm - or the distance should be greater than 230 mm.

d) **WARNING** Do not use the upper bunk bed or a raised bed if a part of the structure is missing or broken. Spare parts should be requested from the manufacturer or shop.

e) It is essential that the manufacturer's instructions on assembly and use are followed.

f) The recommended size of the mattress to be used with the bed is 1900 mm x 900, Maximum mattress thickness: 164mm,

g) Mattresses must be aired to maintain a low humidity and to stop moisture building up in the bed and its surroundings.

k) The fastenings put in place on assembly should all be properly tightened and regularly checked. Retighten the fastenings as necessary.

l) This complies with the requirements of the European Safety Standard EN 747+A1: 2015.

m) The presence of a night light could give more safety for a child sleeping in an upper bed.

FR Notice de montage

IMPORTANT - LIRE ATTENTIVEMENT - A CONSERVER POUR REFERENCE ULTERIEURE

a) **AVERTISSEMENT** Les lits surélevés et le lit supérieur des lits superposés ne conviennent pas pour les enfants de moins de six ans en raison du risque de blessures liées à des chutes,

b) **AVERTISSEMENT** S'ils ne sont pas utilisés correctement, les lits superposés et les lits surélevés peuvent présenter un sérieux risque de blessure par étranglement. Ne jamais attacher ou suspendre des éléments à des parties du lit superposé qui ne sont pas destinés à être utilisés avec ledit lit. Ces éléments comprennent, sans toutefois s'y limiter, les cordes, les ficelles, les cordons, les crochets, les ceintures et les sacs,

c) **AVERTISSEMENT** Les enfants peuvent se retrouver coincés entre le lit et un mur, une partie d'un toit incliné, le plafond, des meubles adjacents (par exemple, des placards) ou autre. Pour éviter tout risque de blessure grave, la distance entre la barrière de sécurité supérieure et les éléments environnants ne doit pas dépasser 75 mm ou doit être supérieure à 230 mm,

d) **AVERTISSEMENT** Ne pas utiliser le lit superposé ou le lit surélevé si une pièce de la structure est manquante ou cassée. Les pièces de rechange doivent être demandés auprès du fabricant ou du magasin.

e) Il est impératif de toujours suivre les instructions de montage et d'utilisation du fabricant,

f) La taille recommandée du matelas à utiliser avec le lit est de 1900mm x 900mm, **Epaisseur du matelas maximum : 164mm,**

g) Il est nécessaire de ventiler la pièce afin de maintenir un niveau peu élevé d'humidité et d'empêcher le développement de moisissure dans le lit et sa périphérie,

k) Les dispositifs d'assemblage doivent toujours être convenablement serrés et régulièrement vérifiés. Les resserrer si nécessaire.

l) Conforme aux exigences européenne de sécurité de la norme EN 747+A1 : 2015.

m) la présence d'une veilleuse de nuit peut procurer plus de sécurité à l'enfant couchant dans le lit haut

IT Istruzioni per montaggio

IMPORTANTE - LER ATENTAMENTE - A GUARDAR PARA REFERENCIA FUTURA

a) **AVVERTENZE** I letti a soppalco ed il letto superiore dei letti a castello non sono adatti ai bambini di età inferiore ai sei anni per i rischi di lesioni dovute a cadute,

b) **AVVERTENZE** Se non utilizzati correttamente, i letti a castello ed i letti a soppalco possono rappresentare un importante rischio di lesioni da strangolamento. Non legare o sospendere mai elementi a delle parti del letto a castello che non siano previsti per essere utilizzati con il suddetto letto. Questi elementi comprendono, senza tuttavia esserne limitati, le corde, gli spaghi, i cordoncini, i ganci, le cinghie ed i sacchi,

c) **AVVERTENZE** I bambini possono ritrovarsi bloccati tra il letto ed un muro, la parte di un tetto inclinato, il soffitto, i mobili adiacenti (per esempio gli armadi) o altro. Per evitare qualsiasi rischio di lesione grave, la distanza tra la sponda di sicurezza superiore e gli elementi circostanti non deve superare 75 mm o deve essere superiore a 230 mm,

d) **AVVERTENZE** Non utilizzare il letto a castello o il letto a soppalco se un pezzo della struttura manca o se è rotto. I pezzi di ricambio devono essere richiesti al fabbricante o al negozio.

e) Seguire rigorosamente le istruzioni di montaggio e d'uso del fabbricante,

f) La misura consigliata del materasso da usare con il letto è di 1900mm x 900mm, **Spessore massimo del materasso: 164mm,**

g) Per mantenere un livello poco elevato di umidità, e per impedire lo sviluppo di muffa nel letto e intorno al letto, ventilare la stanza,

k) I dispositivi d'assemblaggio devono sempre essere adeguatamente stretti e regolarmente verificati. Ristringere se necessario.

l) Conforme alle esigenze europee di sicurezza della norma EN 747+A1: 2015.

m) la presenza di una luce notturna può dare più sicurezza al bambino che dorme nel letto superiore

1

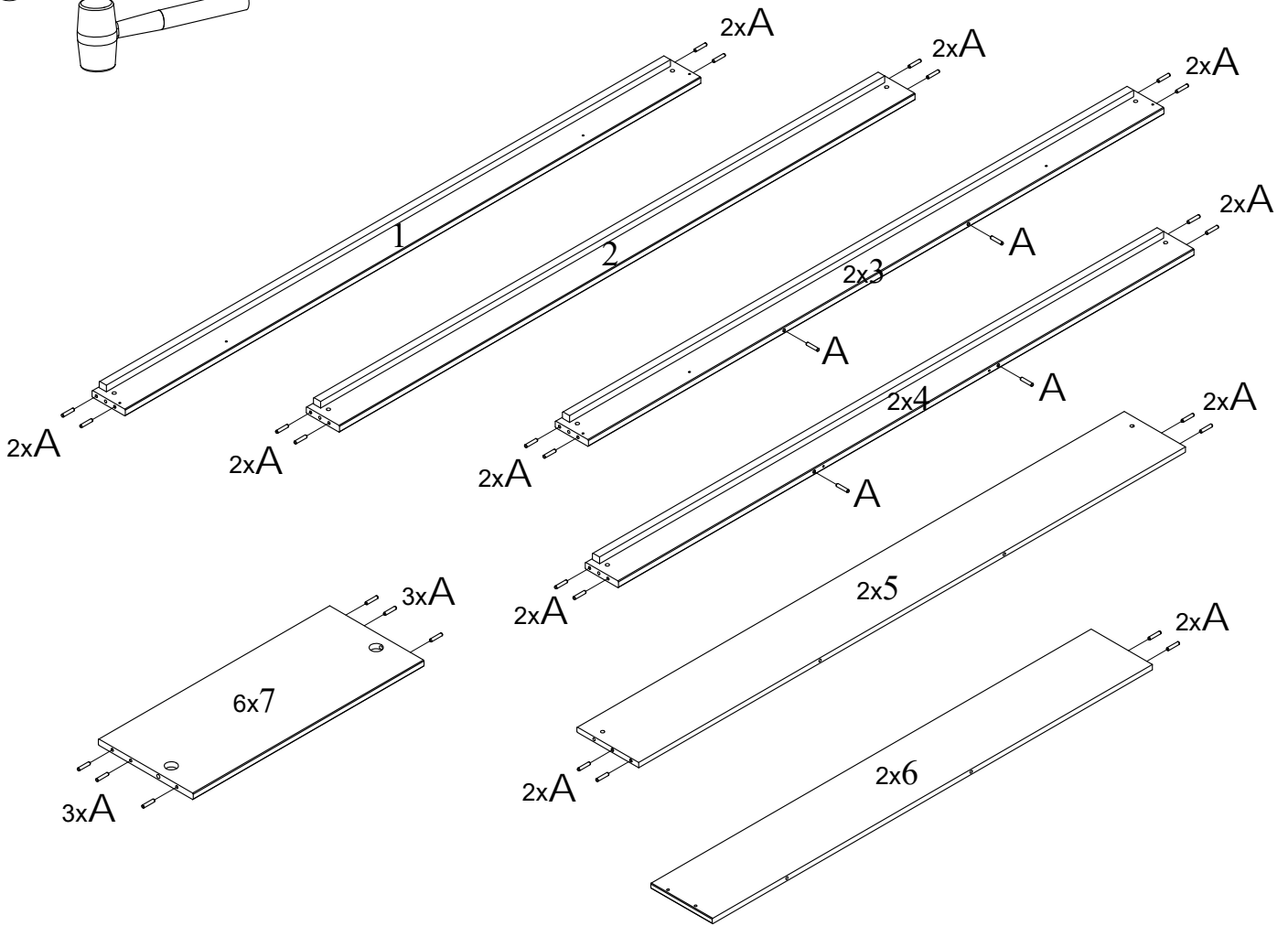
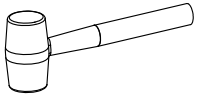

A		8x40	x80
---	---	------	-----

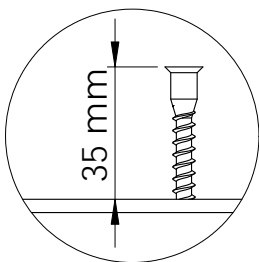
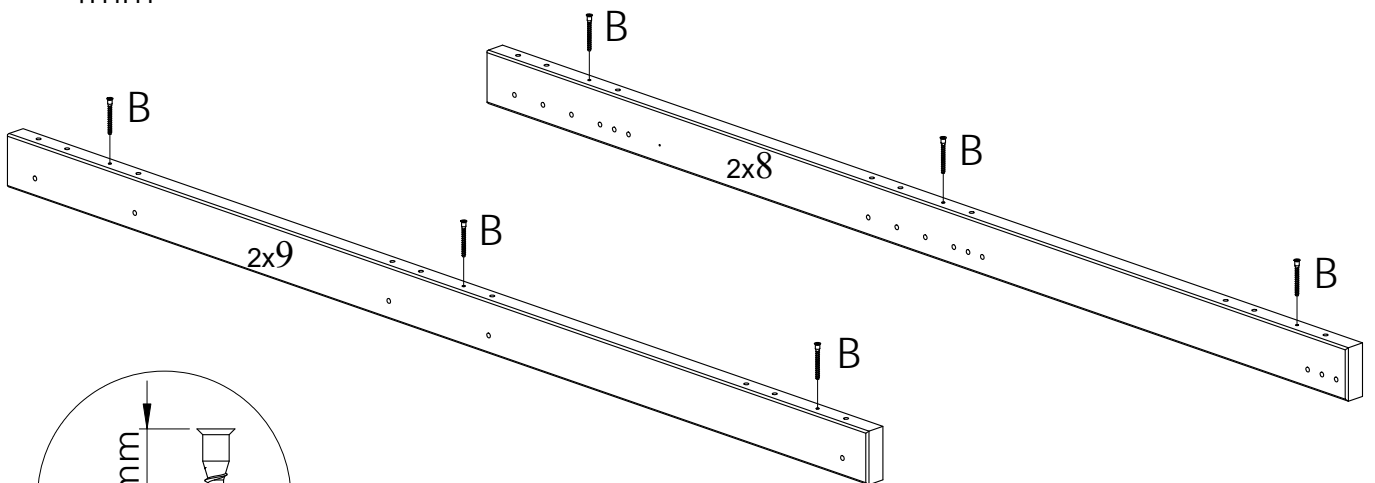

2

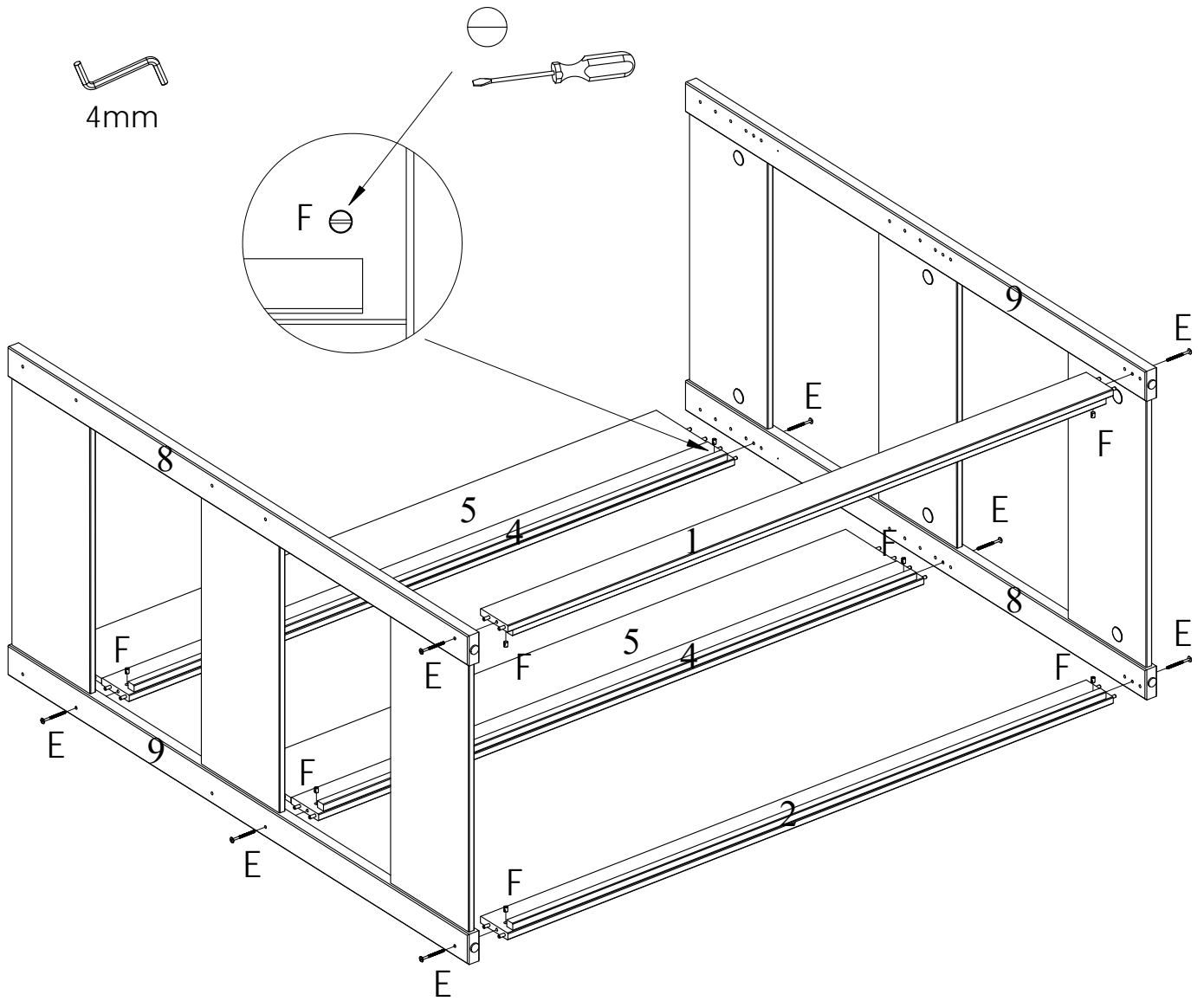

B		7x60	x12
---	---	------	-----

6



E		M6x75	x8
F		M6x10x13	x8

7

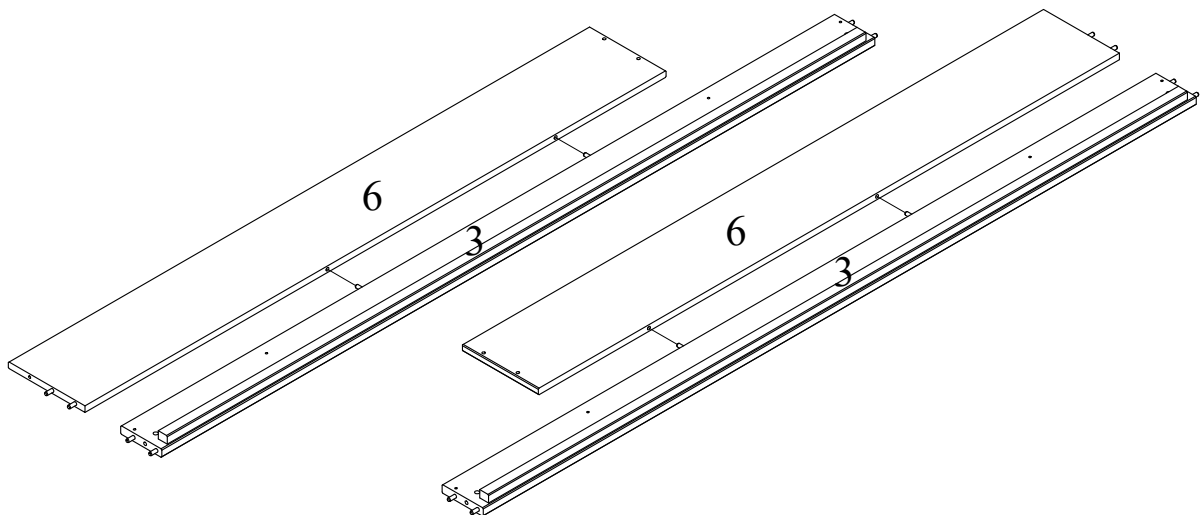

8a

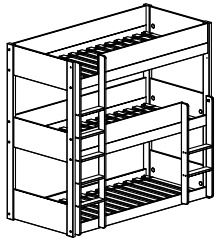

A

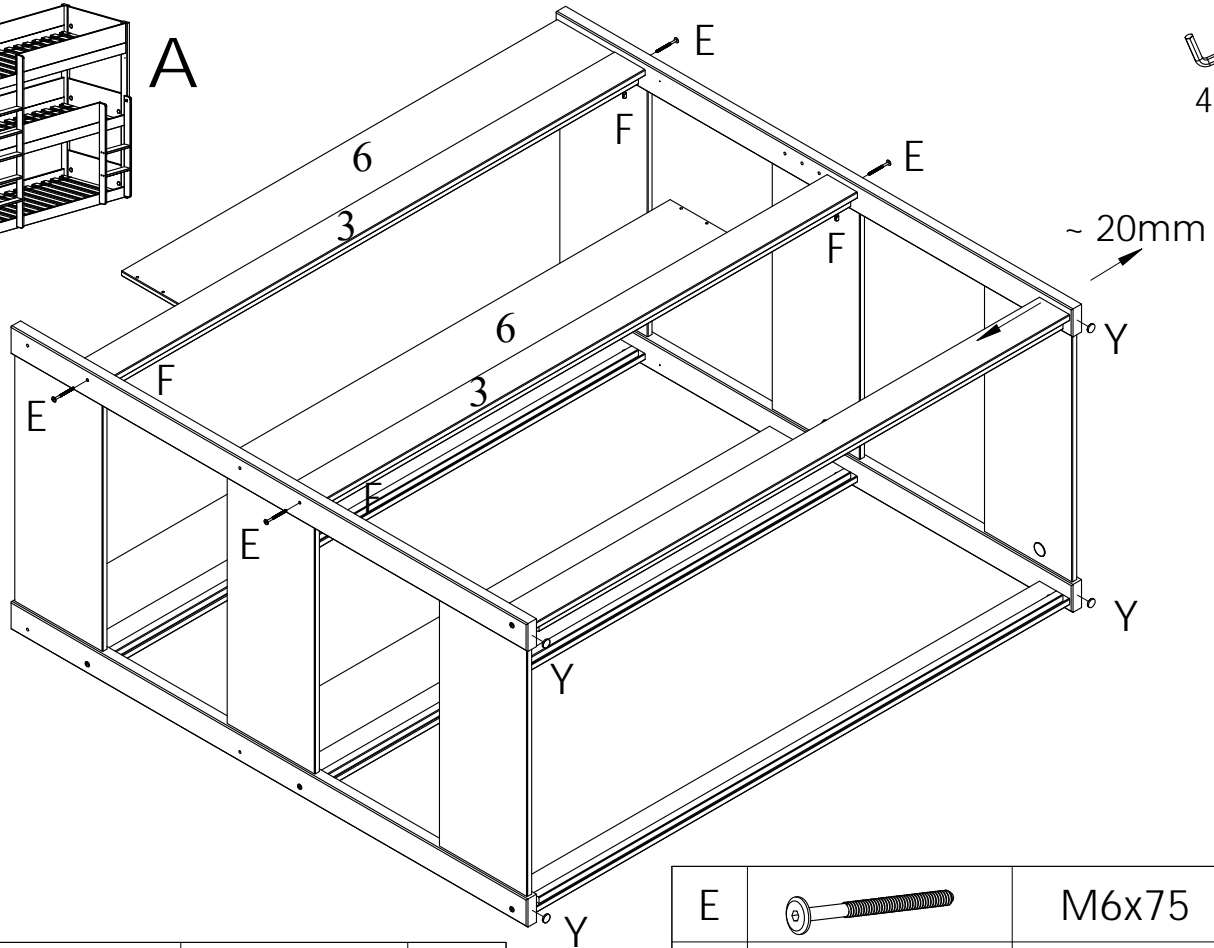

4mm

~ 20mm

Y



D25x3

x4

E



M6x75

x4

F



M6x10x13

x4

8b

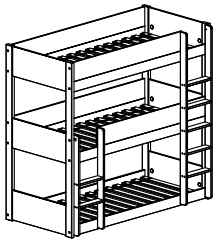

B

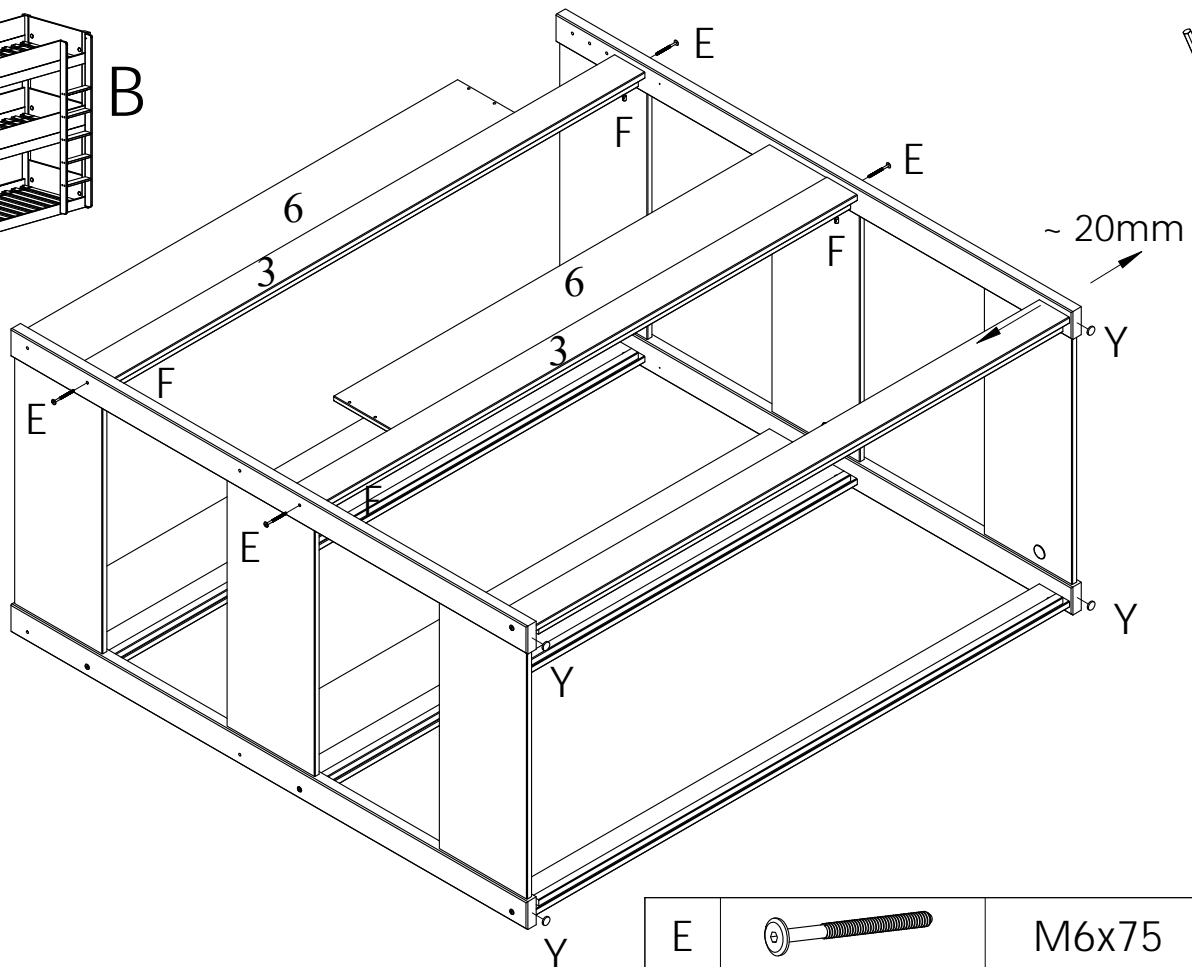

4mm

~ 20mm

Y



D25x3

x4

E



M6x75

x4

F



M6x10x13

x4

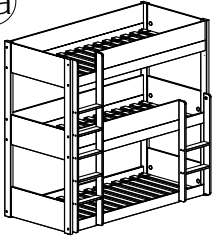

9a

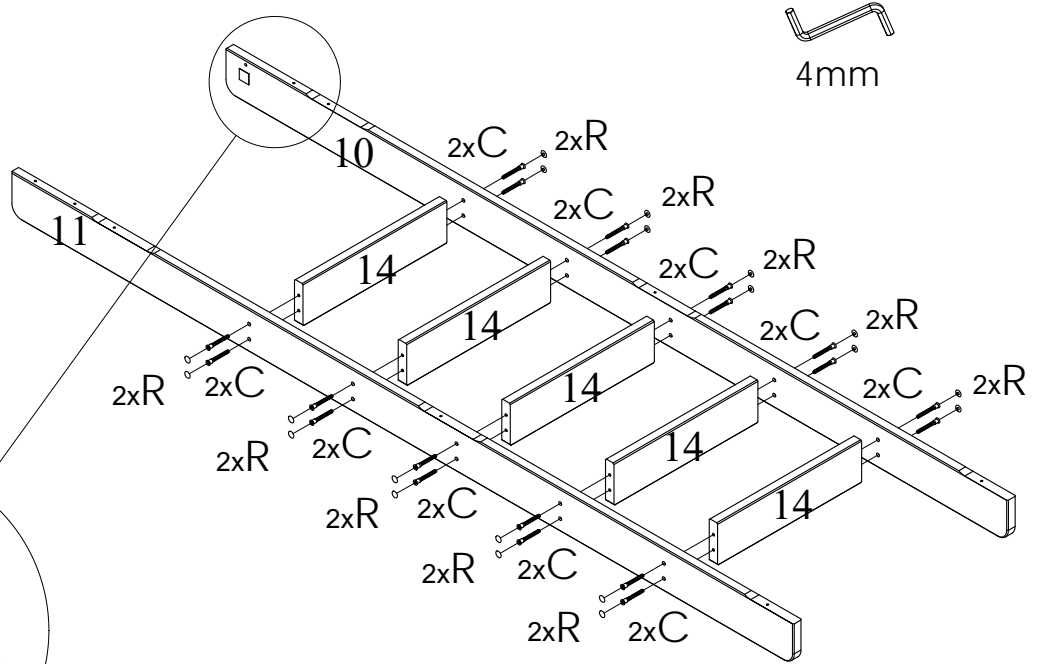
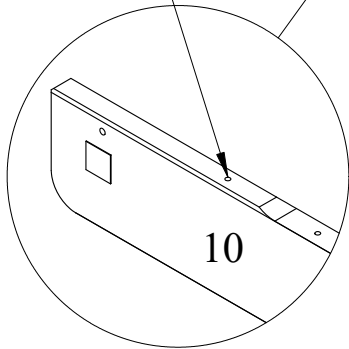

A

D: Max. Höhe der Matratze
 GB: Maximum height of mattress
 F: Hauteur maximum du matelas
 I: Altezza massima del materasso



C		7x50	x20
R		D4x13	x20

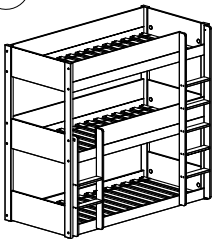

9b

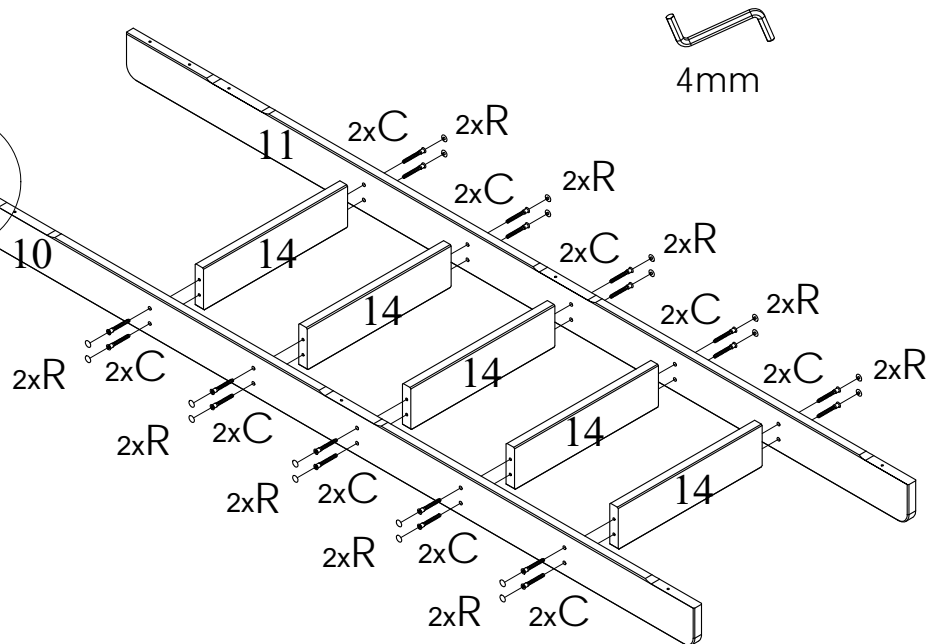
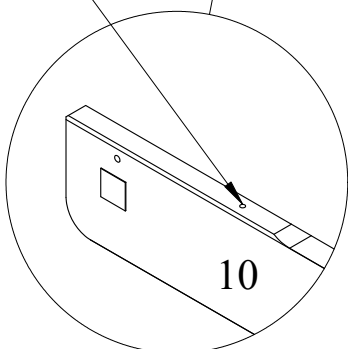

B

D: Max. Höhe der Matratze
 GB: Maximum height of mattress
 F: Hauteur maximum du matelas
 I: Altezza massima del materasso



C		7x50	x20
R		D4x13	x20

10a

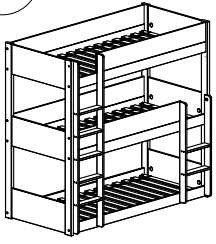



A

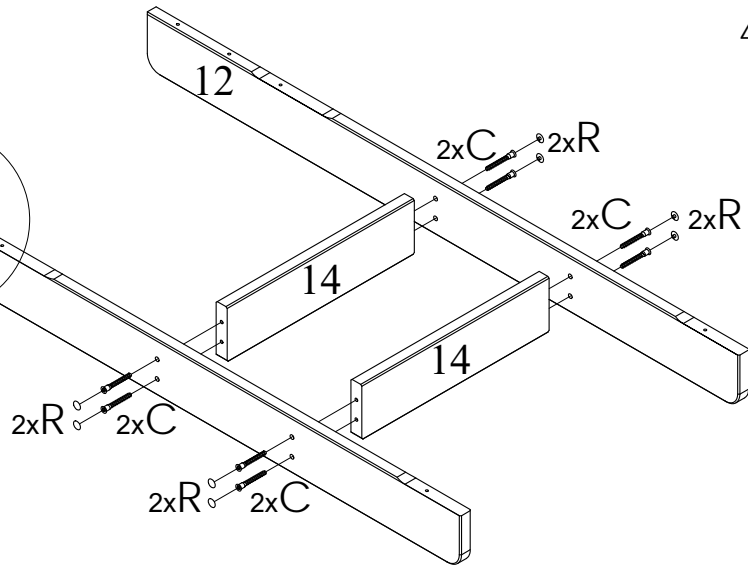
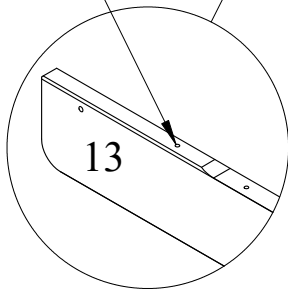

4mm

D: Max. Höhe der Matratze
 GB: Maximum height of mattress
 F: Hauteur maximum du matelas
 I: Altezza massima del materasso



C		7x50	x8
R		D4x13	x8

10b

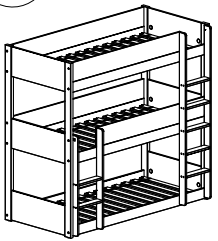



B

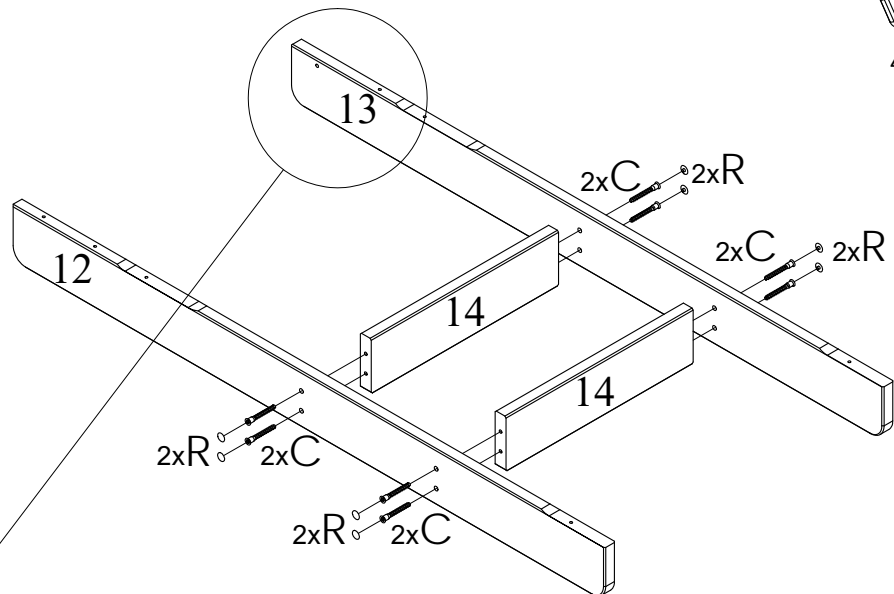
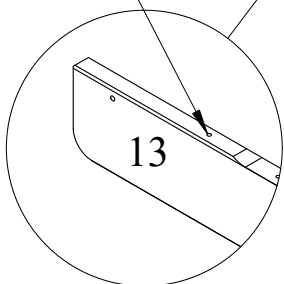

4mm

D: Max. Höhe der Matratze
 GB: Maximum height of mattress
 F: Hauteur maximum du matelas
 I: Altezza massima del materasso



C		7x50	x8
R		D4x13	x8

11a

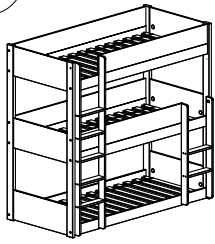





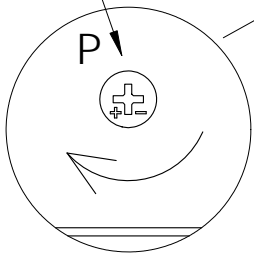
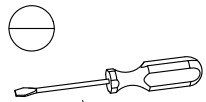
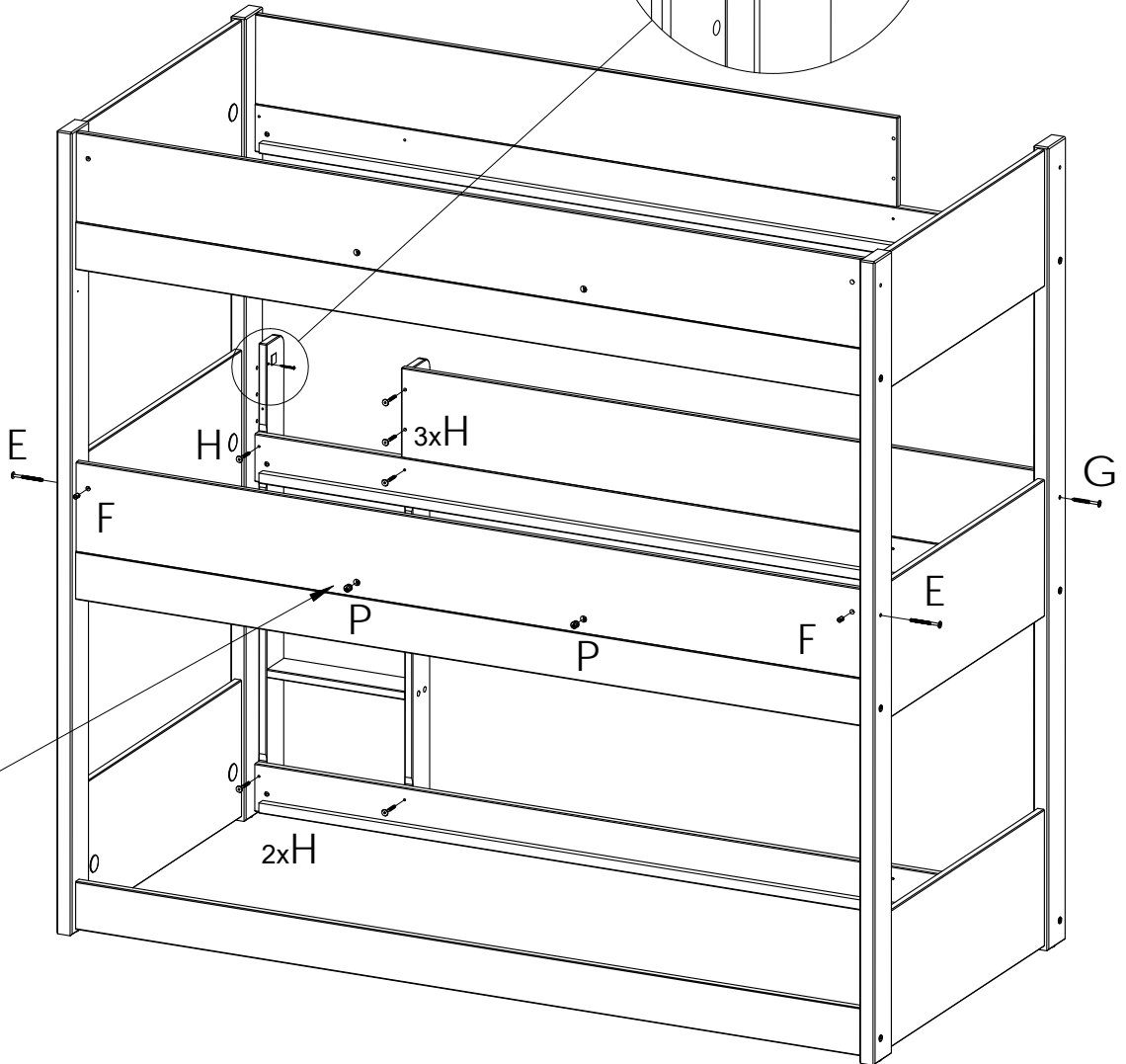
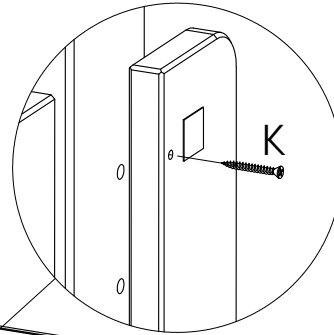
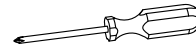

A

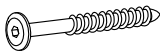

4mm



G		6,3x70	x1
H		55/12,2x5	x6
K		4,2x35	x1

E		M6x75	x2
F		M6x10x13	x2
P		D15x13,5	x2

11b

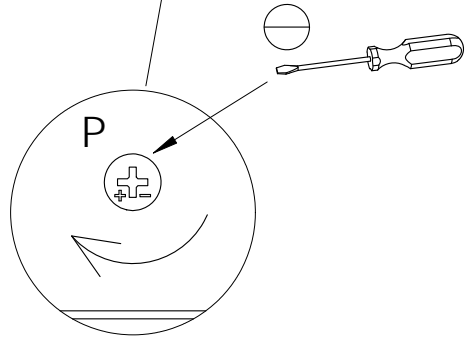
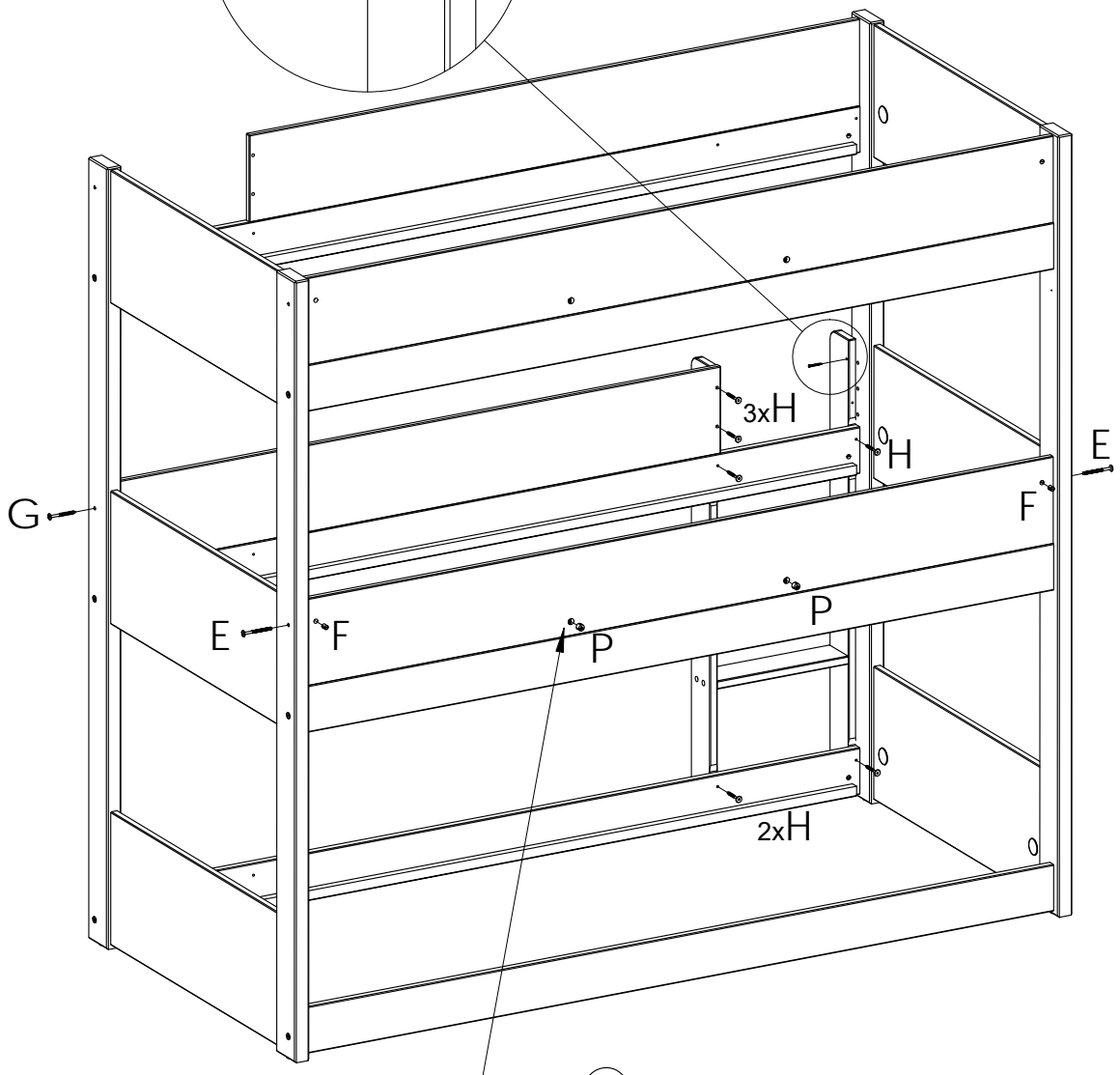
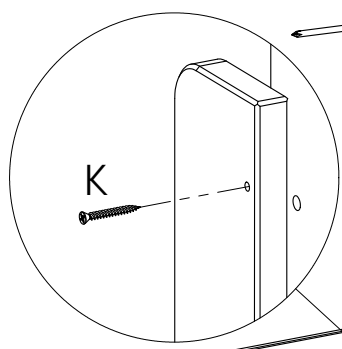
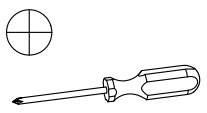
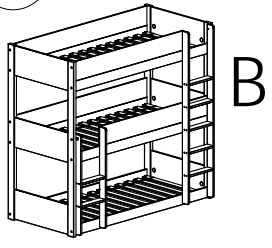

G		6,3x70	x1
H		55/12,2x5	x6
K		4,2x35	x1

E		M6x75	x2
F		M6x10x13	x2
P		D15x13,5	x2

12a

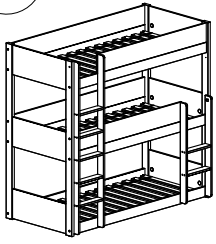



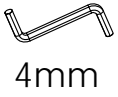
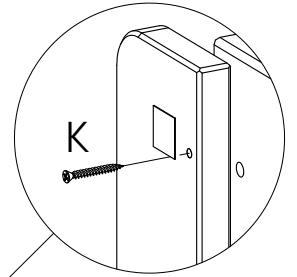
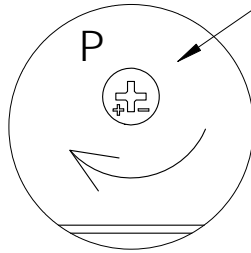
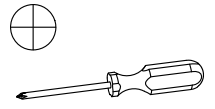
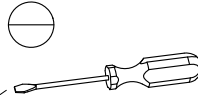

A

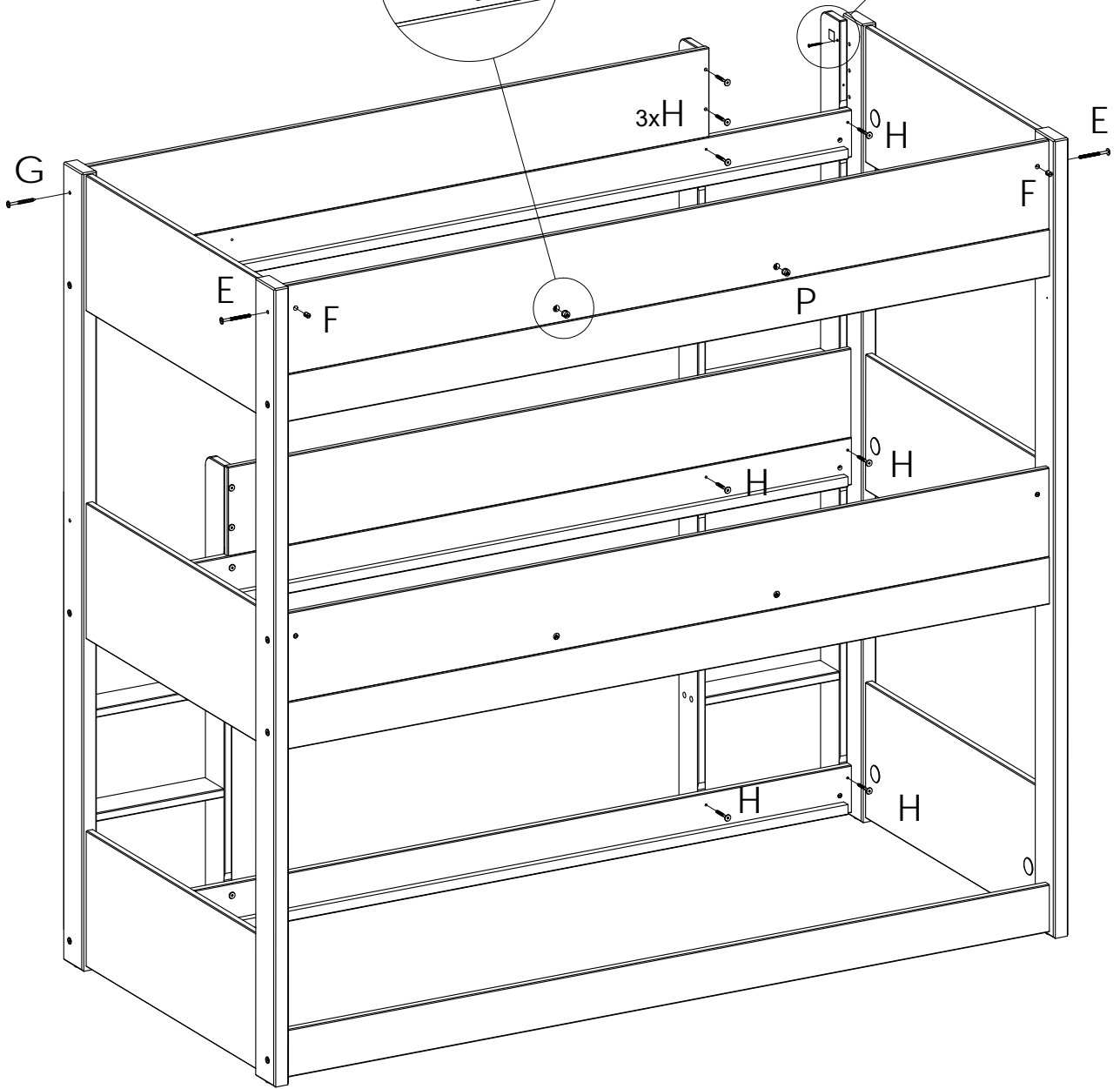
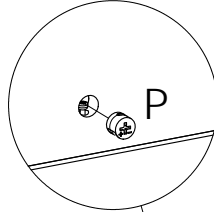

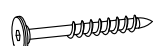
4mm



G		6,3x70	x1
H		55/12,2x5	x8
K		4,3x35	x1

E		M6x75	x2
F		M6x10x13	x2
P		D15x13,5	x2

12b

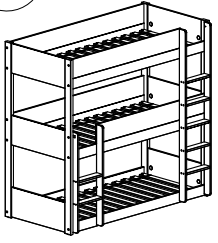

B

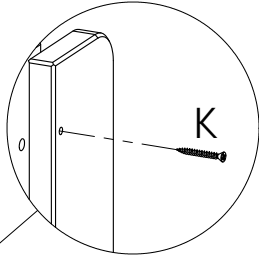
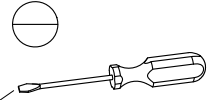
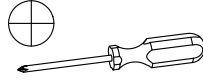

K

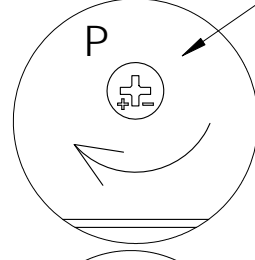

P

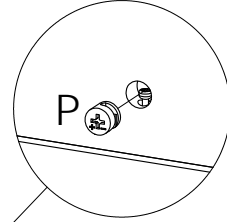

P



4mm

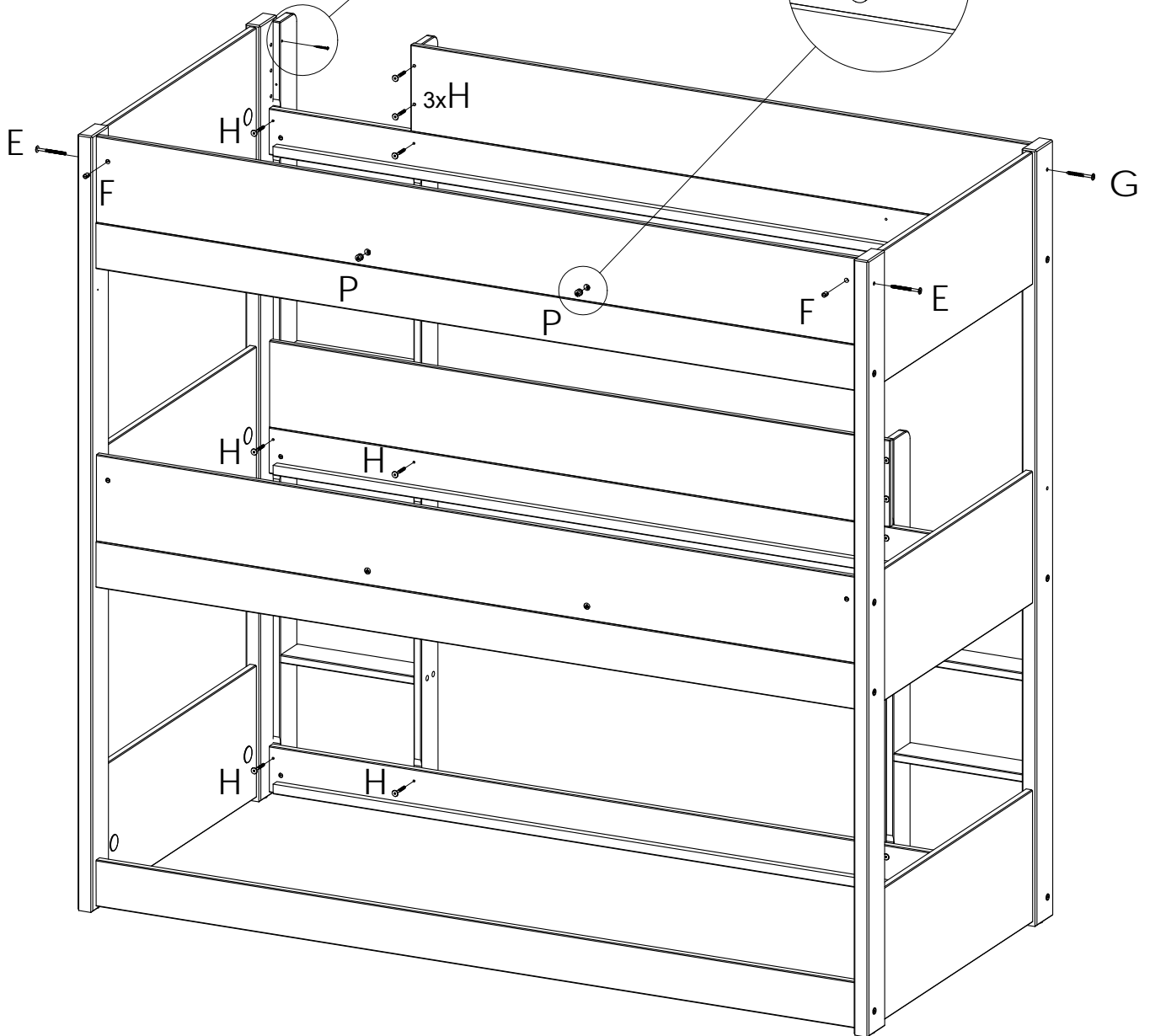

G		6,3x70	x1
H		55/12,2x5	x8
K		4,3x35	x1

E		M6x75	x2
F		M6x10x13	x2
P		D15x13,5	x2

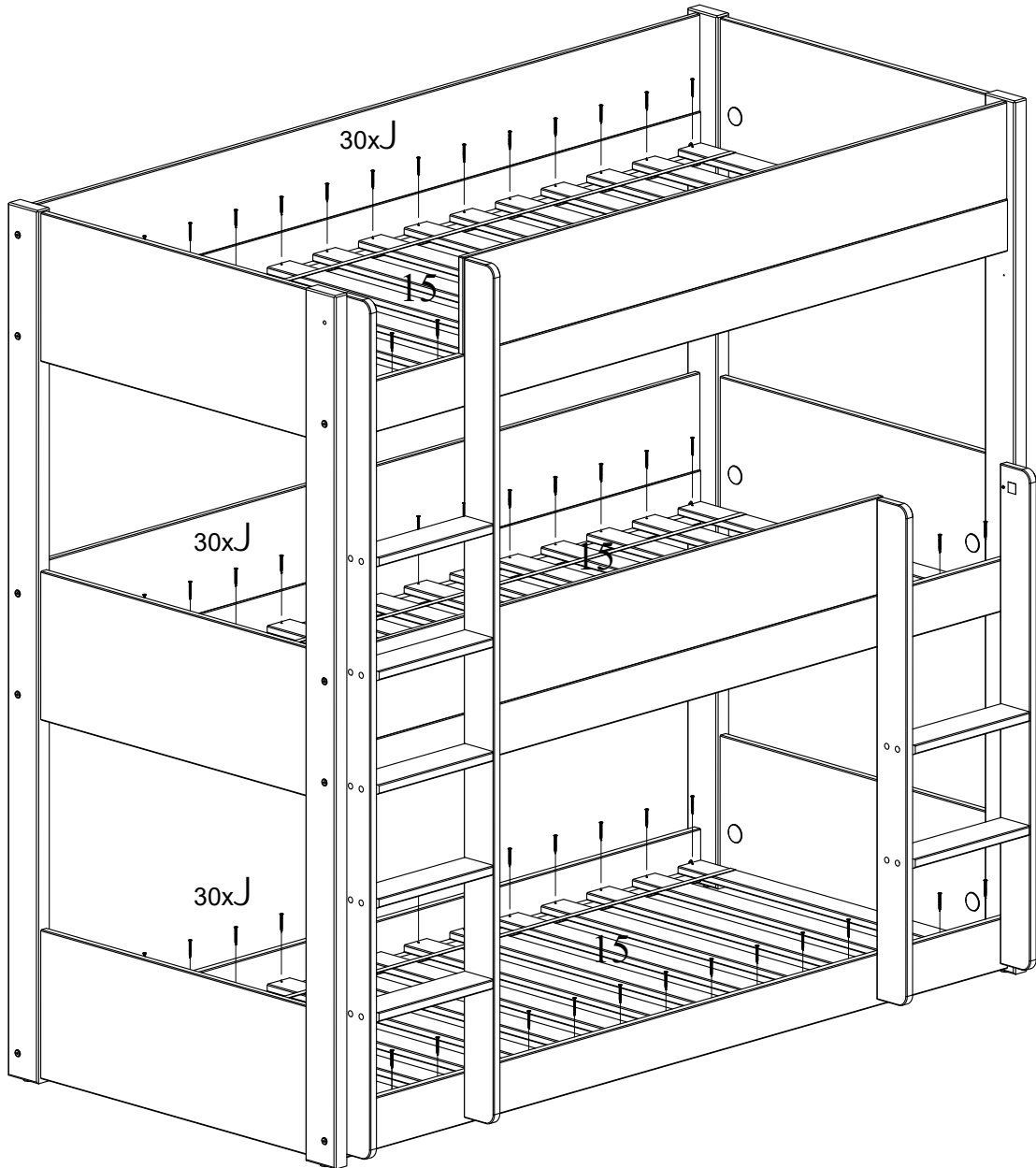
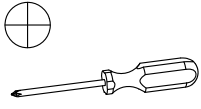

13



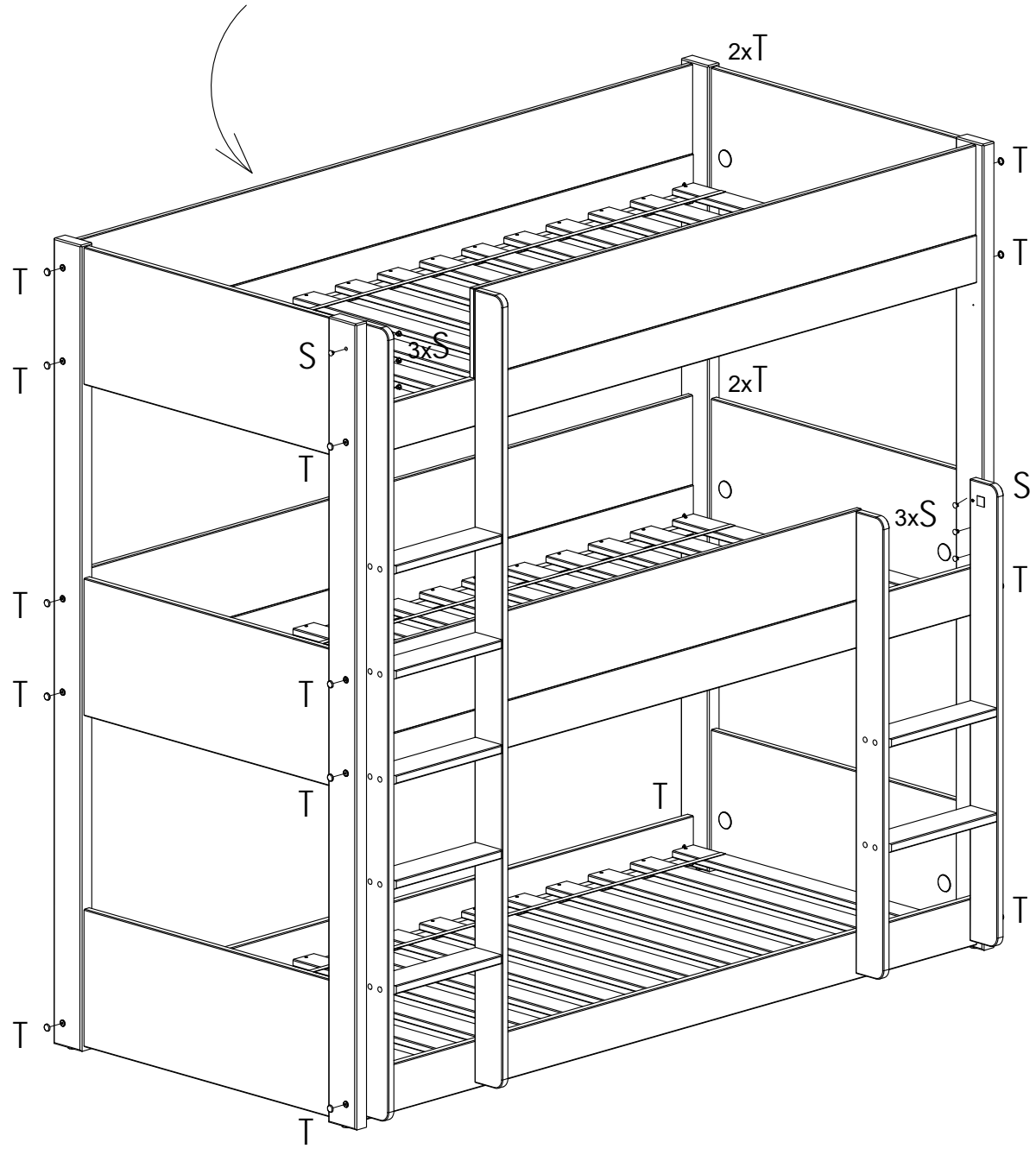
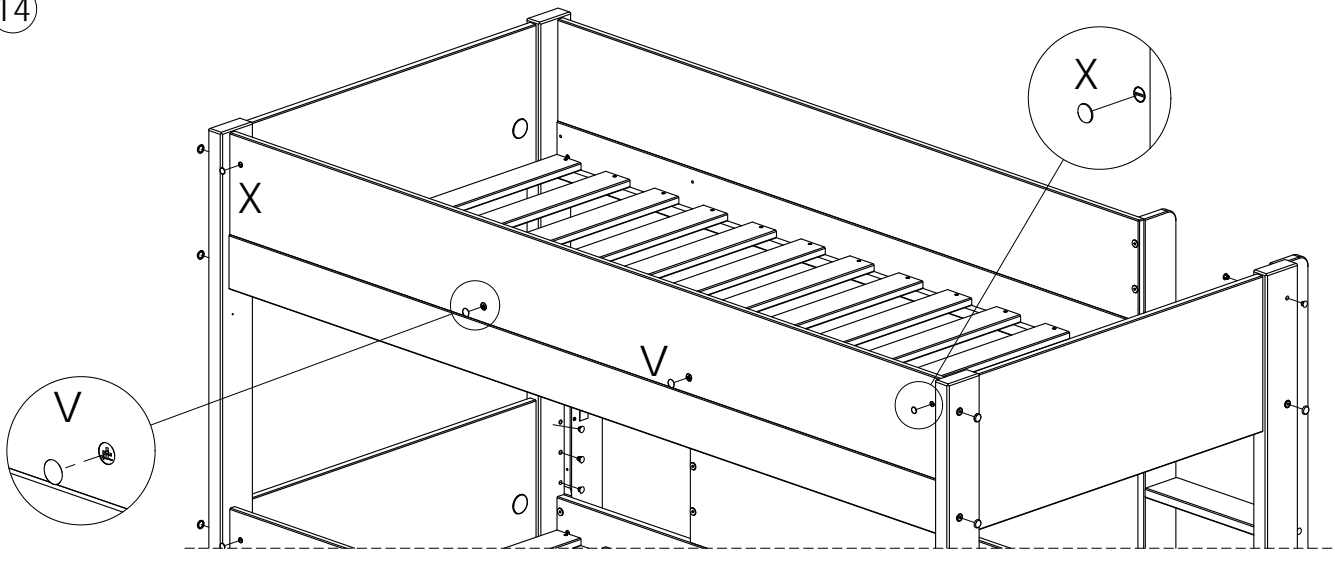

J		3,5x40	x90
---	---	--------	-----

14



S		D8x13	x8
T		D15x18	x18

V		D4x17	x4
X		D13	x4

15

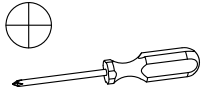

Important! Il est indispensable de fixer le lit mezzanine au mur avec les 2 équerres L. Utiliser des vis et des chevilles adaptés votre mur.

Important! To secure the bed it is necessary to fix the bed to the wall by mounting the 2 brackets L as shown on the illustration.

Wichtig! Es ist notwendig das Bett an der Wand mit zu befestigen - siehe Zeichnung.

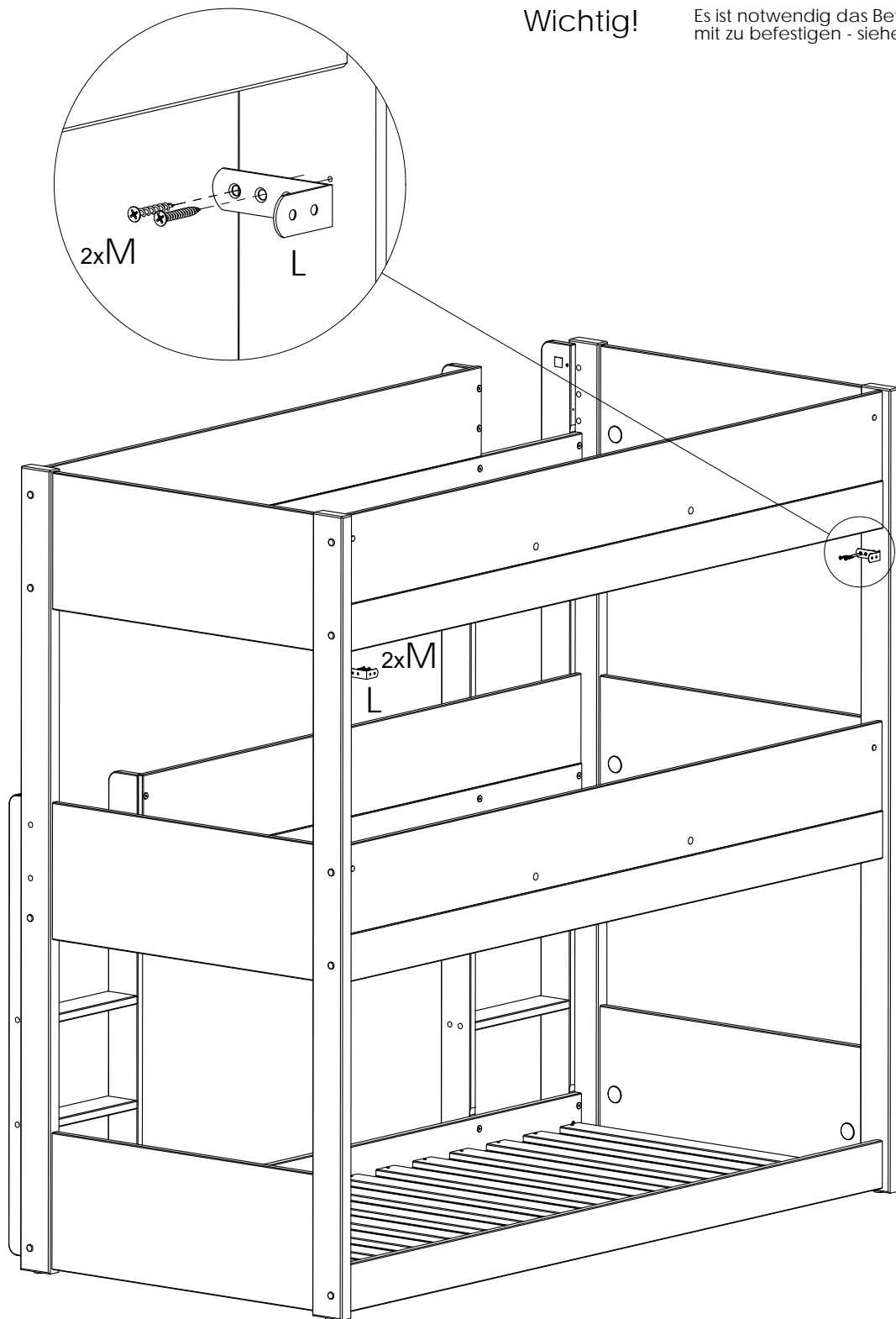

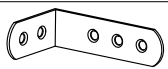
M		4x30	x4
L		20x42x70	x2