

51912

# SALVADOR 4'6" HIGH END BED

## ASSEMBLY INSTRUCTIONS

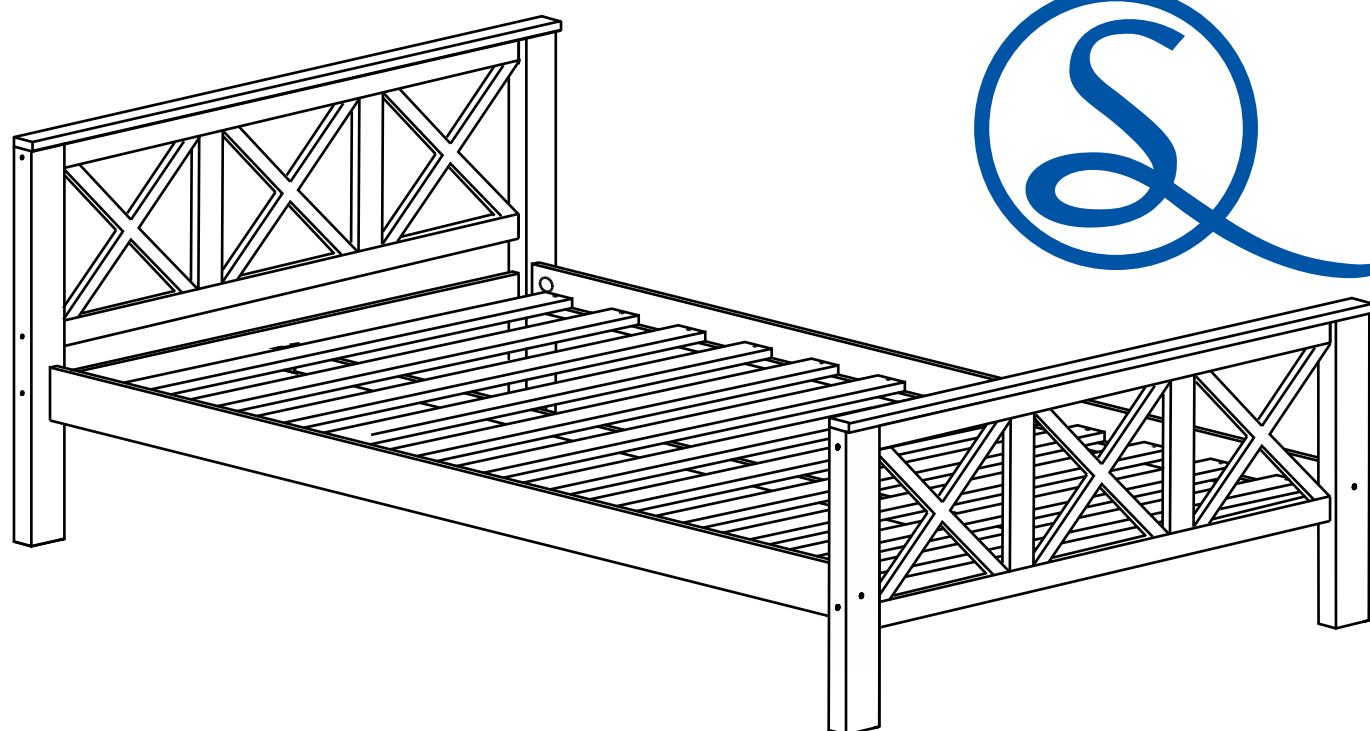

FOR DOMESTIC USE ONLY

IMPORTANT

PLEASE READ BEFORE YOU CONTINUE FURTHER

## CARE AND MAINTENANCE

After unpacking this product please keep the original packaging in case it needs to be returned for any reason.

- Please ensure all fittings and parts are present before commencing with assembly.
- We recommend that you lay a blanket or sheet on the floor to avoid damage to both your floor and the product.
- We strongly recommend that you keep children away from your work area.
- Assemble this product as close to its final position as possible.
- Never drag or push products as this could cause damage to the joints making it inferior.
- Do not place this product next to a radiator or in direct sunlight.
- Wood is a natural product and may expand if subjected to damp and may shrink or crack if subjected to heat. Therefore it is recommended that room temperature is maintained, with no sudden temperature fluctuations.
- Make sure any spillage is wiped off immediately.
- Do not place hot or chilled items directly on to the surface, use a place mat or marking will occur.
- For general cleaning use a duster, and do not use detergents of any kind. However, the surface will need to be retreated from time to time. This can be done by using block wax (unperfumed) and rubbing it over the whole item.
- From time to time it may be necessary to tighten fittings, regular inspections should be carried out.

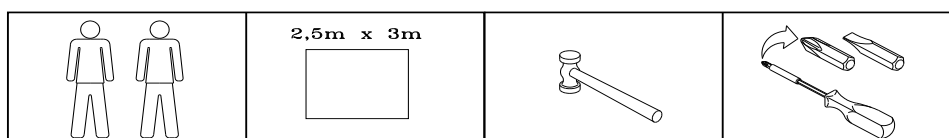
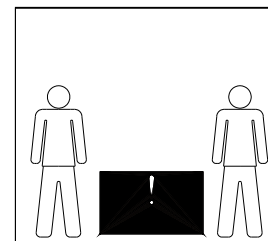
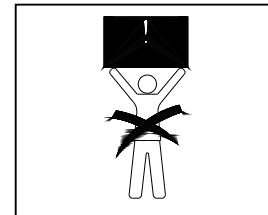
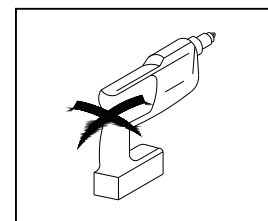
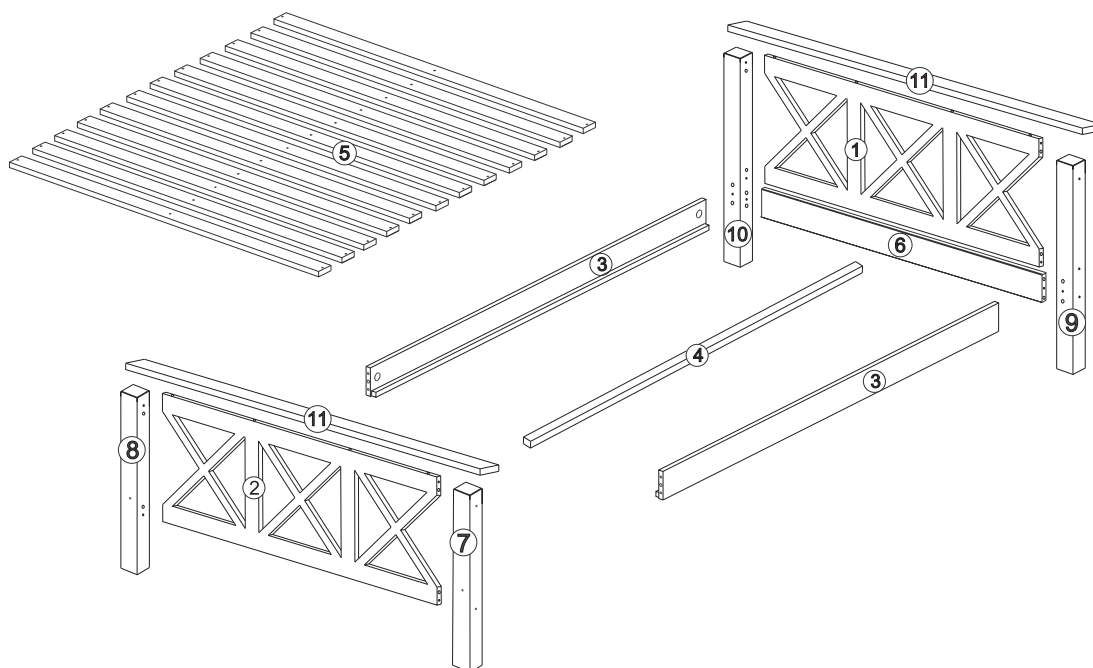

**\*Use of power tools to assemble this product will invalidate any claim and could damage this product making it unsafe!!!**  
**\*Please assemble on a clean soft surface to avoid damage.**

**\*Please check contents and read the instructions before commencing assembly.**  
**\*Assemble this product following the enclosed instructions carefully.**  
**\*Please take care to avoid damaging parts during assembly.**

### PARTS LIST

1	HEADBOARD PANEL	01	7	RIGHT FOOTBOARD POST	01
2	FOOTBOARD PANEL	01	8	LEFT FOOTBOARD POST	01
3	SIDERAIL	02	9	RIGHT HEADBOARD POST	01
4	CENTRE SUPPORT RAIL	01	10	LEFT HEADBOARD POST	01
5	SLAT	12	11	TOP PLINTH	02
6	HEADBOARD CROSSBAR	01			

### FITTINGS

A		04	I		02
B		04	J		02
C		36	K		02
D		08	L		10
E		01	M		01
F		02	N		12
G		08	O		08
			P		06

# PRE-ASSEMBLY

**!**  
Glue must be added to the dowel holes on parts 1,2,3 and 6.

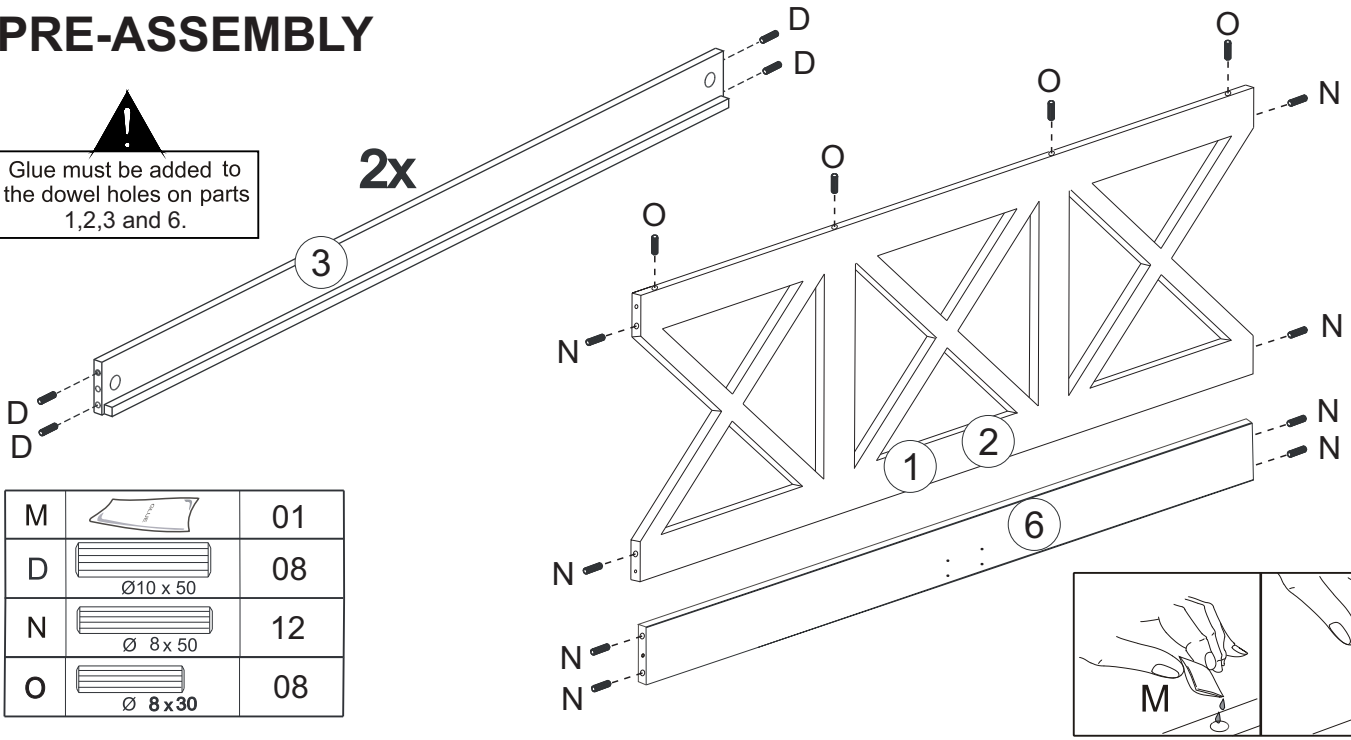

M		01
D	 Ø10 x 50	08
N	 Ø 8 x 50	12
O	 Ø 8 x 30	08

# STEP 1

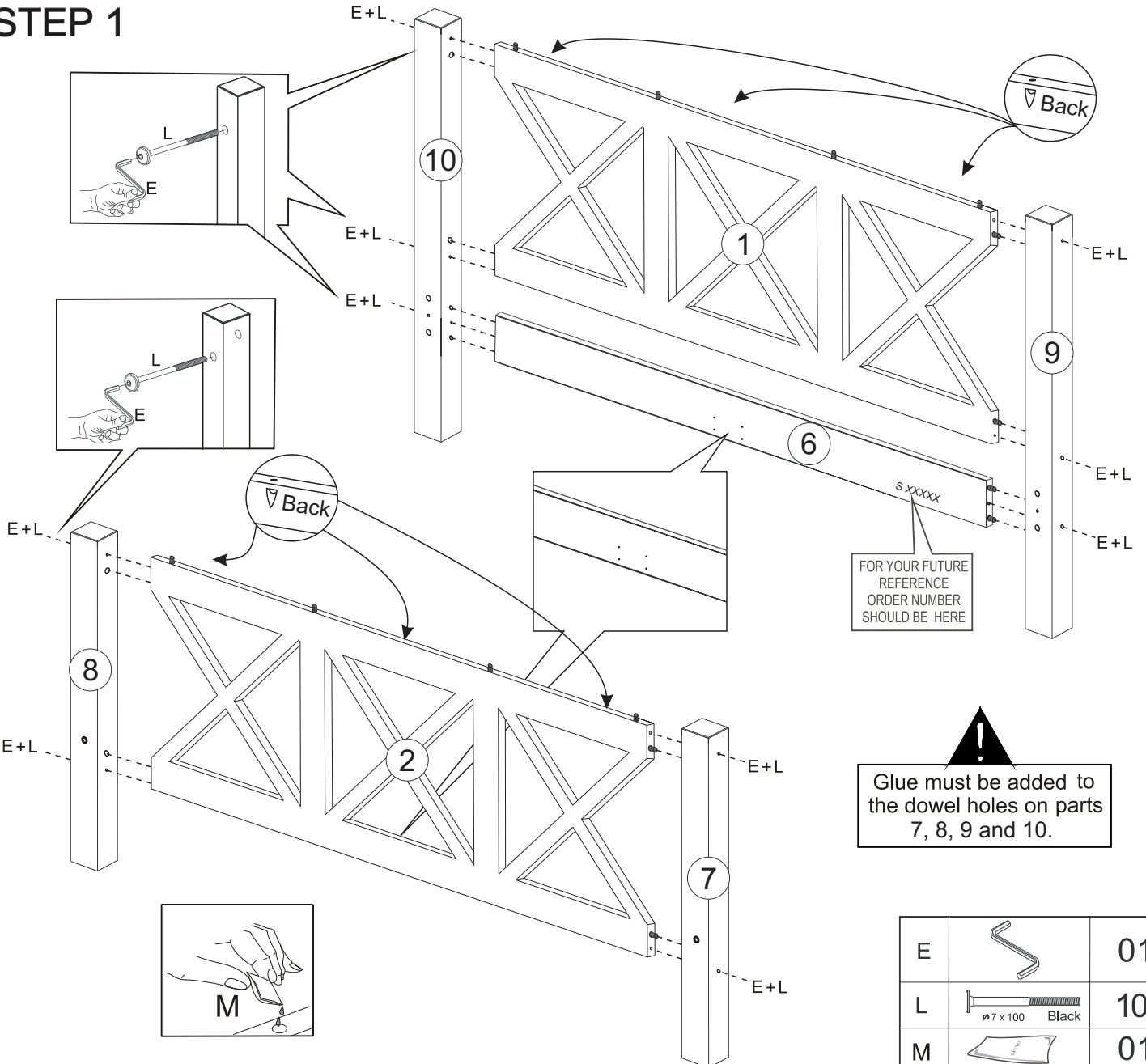





FOR YOUR FUTURE REFERENCE ORDER NUMBER SHOULD BE HERE

**!**  
Glue must be added to the dowel holes on parts 7, 8, 9 and 10.

E		01
L	 Ø7 x 100 Black	10
M		01

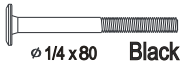
# STEP 2

Glue must be added to the dowel holes on part 11.

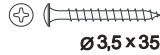
A		04
B		04
E		01
M		01
P		06

# STEP 3

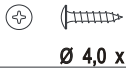
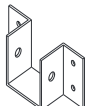

When fixing the support (J) carefully line up the screw holes with those pre-drilled on the Headboard and footboard, this will ensure the best assembly

G		08
J		02

**! THE USE OF POWER TOOLS TO ASSEMBLE THIS PRODUCT WILL INVALIDATE ANY CLAIM MAKING THE PRODUCT UNSAFE!!!!**

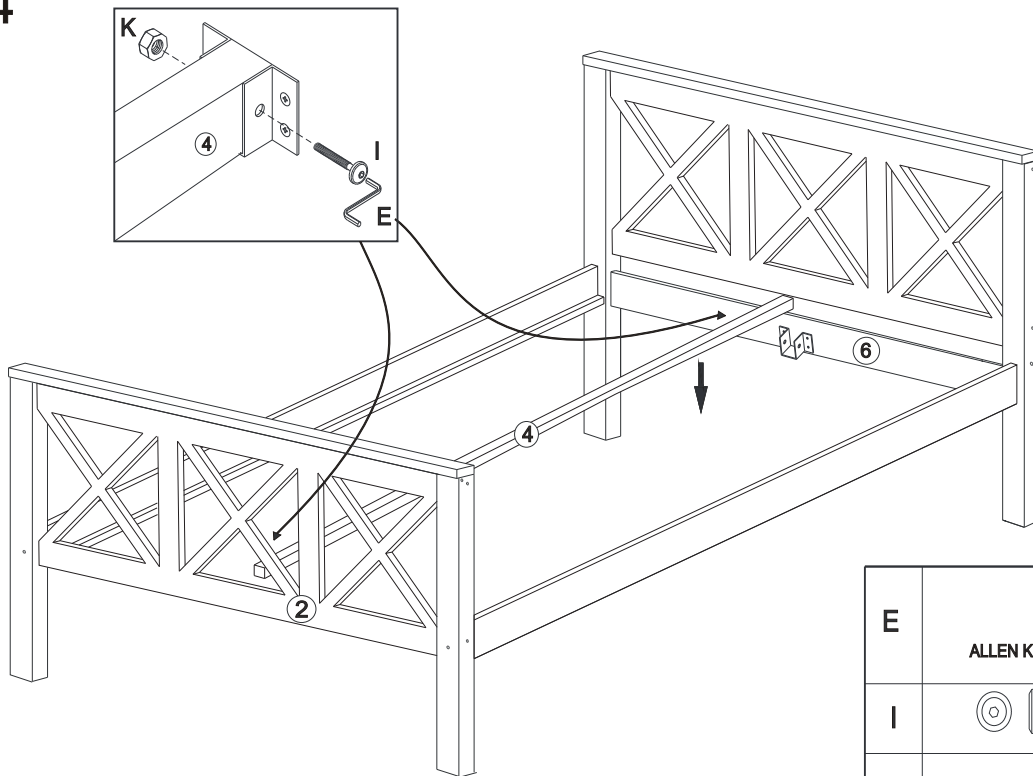

# STEP 4

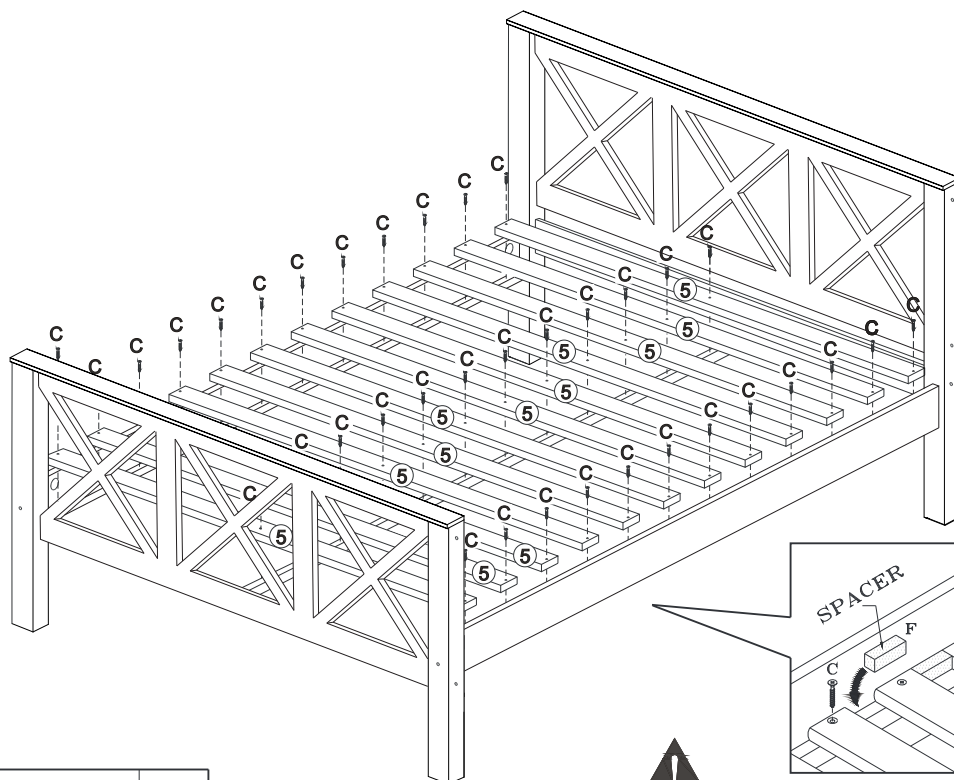
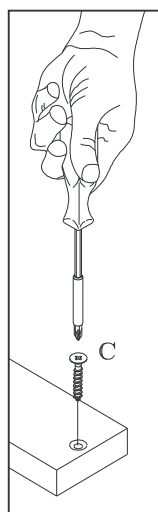

E	 ALLEN KEY	01
I	 Ø1/4" x 60	02
K	 1/4"	02

# STEP 5



C	 Ø 4,0 x 30	36
F	SPACER (WOODEN) 	02

**!**  
Please fix the first slats adjacent to the headboard and footboard and work towards the middle of the bed using the spacer ( F ) as shown to ensure correct spacing. Fix all the slats to one siderail first then push the second siderail tight against the slats and fix.

**!**  
THE USE OF POWER TOOLS TO ASSEMBLE THIS PRODUCT WILL INVALIDATE ANY CLAIM MAKING THE PRODUCT UNSAFE!!!!