



Birlea

Suppliers of inspiration

Assembly Instructions

Thank you for purchasing a Birlea product.

For a chance to win a Love 2 Shop voucher simply post a picture of your new product on your preferred social channels tagging Birlea Furniture and using the hashtag #ShareYourStyle and #Birlea. One winner will be selected at random each month.

To view our full terms and conditions please visit our website. www.birlea.com

Are you happy with your purchase?

Yes: That's great, we would love to hear more from you. Please leave us a review on our social media channels or Trustpilot. Your feedback will be greatly appreciated.

No: If for any reason there is something missing, indifferent or incorrect with your order, please contact the retailer you purchased the item from. We will work with the retailer to resolve your issue as quickly as possible.



www.birlea.com



Birlea

Suppliers of inspiration

Assembly Video

For a step by step guide on how to build our Lynx 3 Door 2 Drawer Robe visit our YouTube channel 'BirleaFurnitureLtd' or alternatively scan the QR code on your smart phone.



How to scan a QR code from an apple device

Step One: Open up the camera app

Step Two: Hold the device's camera up to the QR code

Step Three: Your Apple device will automatically recognise the QR code and provide you with a link to the video.

How to scan a QR code from an android device

Step One: Download the QR Code reader application from the Play Store.

Step Two: Open the QR code application and open the camera.

Step Three: Your Android device will automatically recognise the QR code and provide you with a link to the video.

How to scan a QR code from a Window's device

Step One: Open up the camera app

Step Two: Hold the device's camera up to the QR code

Step Three: Your Window device will automatically recognise the QR code and provide you with a link to the video.

Please ensure that you device is up to date with the latest operating system.



Birlea

Suppliers of inspiration

Vendor: S000139



ASSEMBLY INSTRUCTIONS LYNX 3 DOOR 2 DRAWER ROBE

IMPORTANT: READ THESE INSTRUCTIONS CAREFULLY BEFORE ATTEMPTING TO ASSEMBLE OR USE YOUR LYNX 3 DOOR 2 DRAWER ROBE.

PLEASE KEEP THESE INSTRUCTIONS FOR FUTURE REFERENCE.

ASSEMBLY:

Assembly should be carried out with this item laying flat, not standing upright.

Assemble on a soft, clean surface to prevent damages.

To erase the numbers printed on the pieces, use the rubber into the accessories pack.

HEALTH & SAFETY:

DO NOT use this wardrobe if any parts are missing, damaged or worn.

DO NOT use this wardrobe unless all fixings are secured.

Always use on a level, even surface.

CARE & MAINTENANCE:

Periodically check all screws & fixings to ensure they are secure.







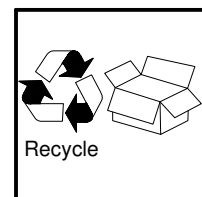
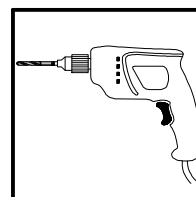
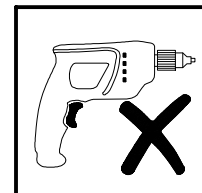
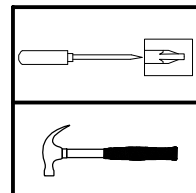
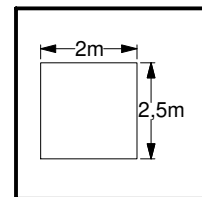
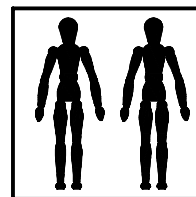
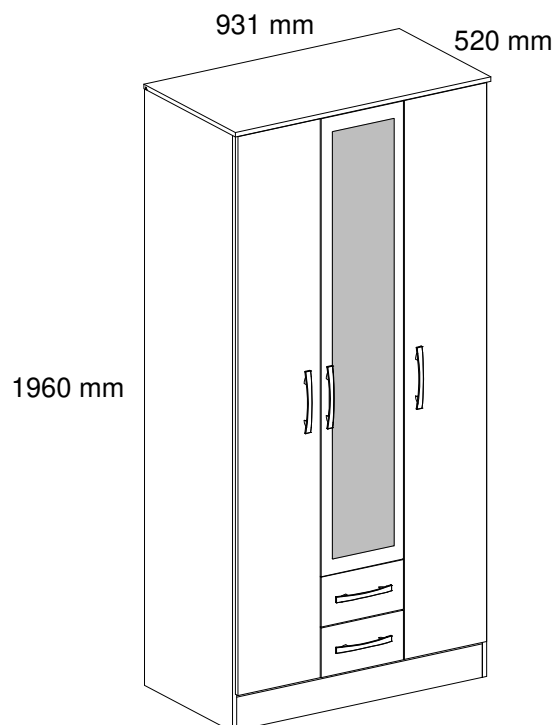

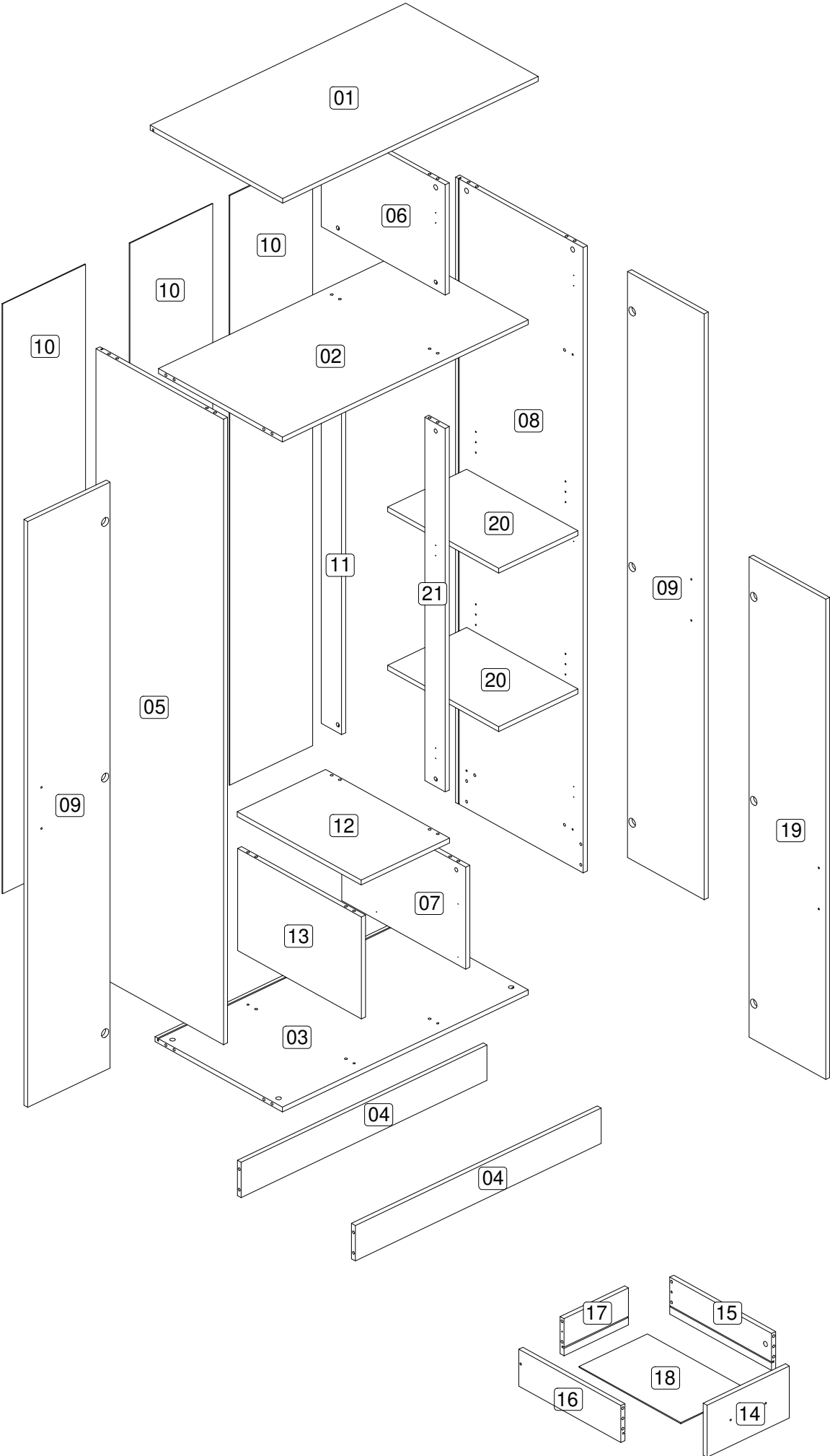

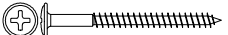





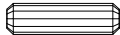



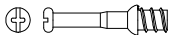

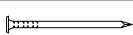
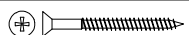
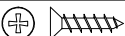

DO NOT push the wardrobe as this will damage the base.

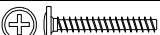
Always lift the wardrobe with two people to reposition.

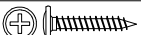
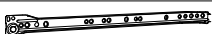
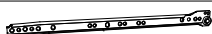
Keep any sharp objects away from the wardrobe.





Parts List				Identification of Accessories			
Part	Description	Box	Qty	Part	Description		Qty
01	Top Panel	1	1	A	5 x 60 mm Screw		1
02	Shelf	1	1	A1	Glue		1
03	Base Panel	1	1	A6	Spine		1
04	Plinth	2	2	B3	Bushing		1
05	Left Panel	1	1	C1	Metal Claw		7
06	Shelf Divider	1	1	D5	Hinge Bracket		9
07	Drawer Cabinet - Right Panel	1	1	E	8 x 30mm Wooden Dowel		44
08	Right Panel	1	1	E7	Small Plastic Foot		4
09	Door	2	2	E9	Strap		1
10	Back Panel	2	3	F	8 x 50mm Wooden Dowel		4
11	Back Support	2	1	F6	Hinge		9
12	Drawer Cabinet - Top Panel	1	1	J	Simple Minifix Screw		20
13	Drawer Cabinet - Left Panel	1	1	K	Double Minifix Screw		4
14	Drawer Front	1	2	L	Cam Lock		28
15	Right Side Drawer Panel	2	2	M	Plastic Cap		24
16	Left Side Drawer Panel	2	2	N	10 x 10mm Tack		11
17	Back Drawer Panel	2	2	O	4.5 x 45mm Screw		8
18	Drawer Base	1	2	P5	3,5 x 14mm Screw		25
19	Mirroed Door	2	1	R4	Hanging Rail		1
20	Shelf	1	2	S	3.5 x 14mm Screw		37
21	Front Support	2	1	T	3.5 x 25mm Screw		10
				T9	Close Rail Support		1
				V4	3.5 x 20mm Screw		2
				WA	Metallic slide the left field		2
				WB	Metallic slide the right field		2
				WC	Drawer slide left		2
				WD	Drawer slide right		2
				W2	Handles		5
				W8	Metalic Shelf Support		8
				Z4	Rail Support		1

**** You will need a small mallet and a screwdriver for assembly.**

**** Some screws and wooden dowel may remain.**

**** Wall plug and screw is supplied to attach strap to the wall.**



Step 2: Prepare these parts for assembly using hardware parts A1, D5, E, E7, F, F6, J, N, P5, S, and WB. You will need to use a small mallet and a screwdriver (not provided).

DO NOT use any power tools as this may damage the frame and will invalidate any claim.

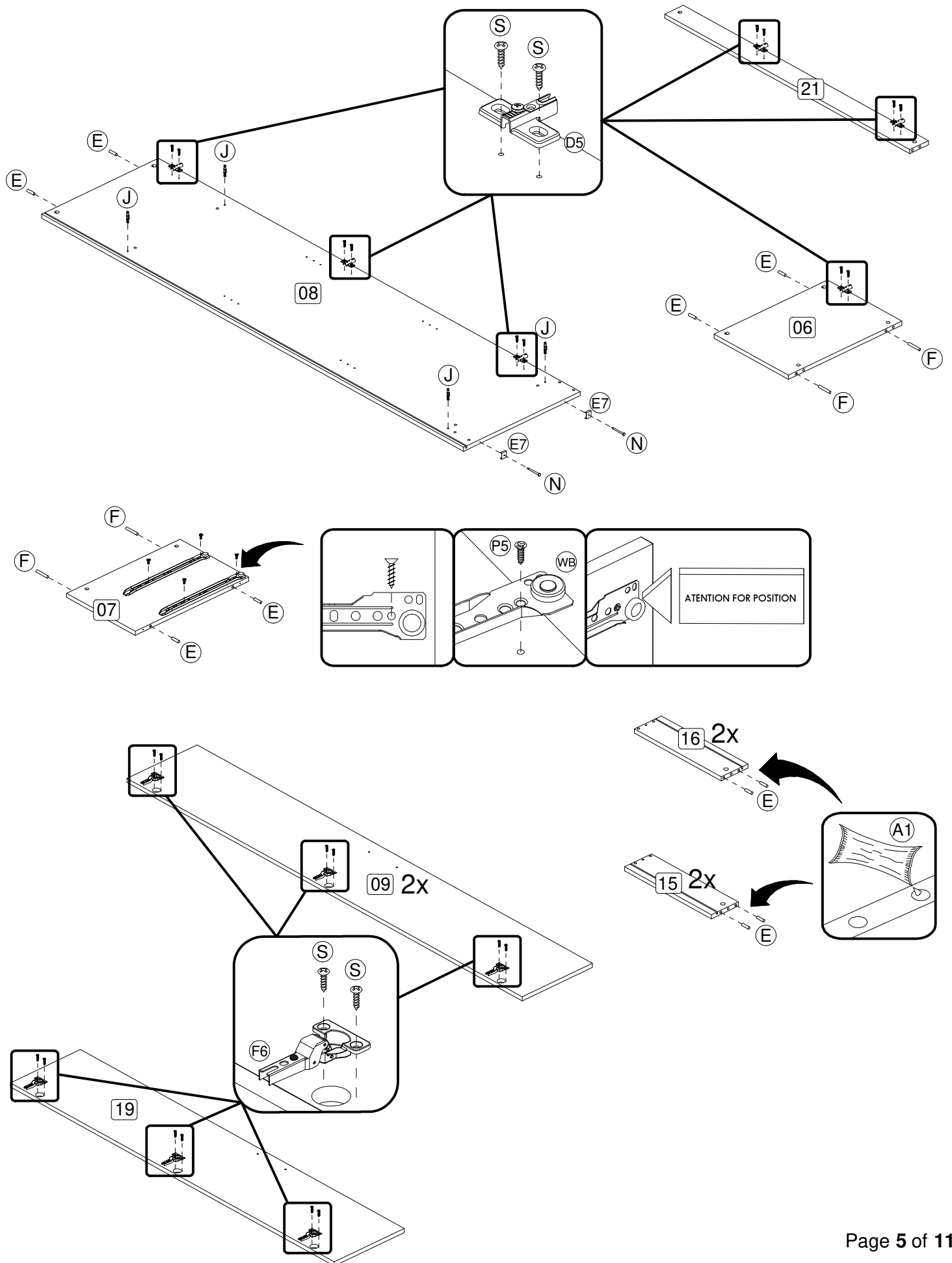

Step 3: Attach the drawer cabinet right panel (7) and drawer cabinet left panel (13) to the base panel (3) using hardware part O and a screwdriver (not provided).

DO NOT use any power tools as this may damage the frame and will invalidate any claim.

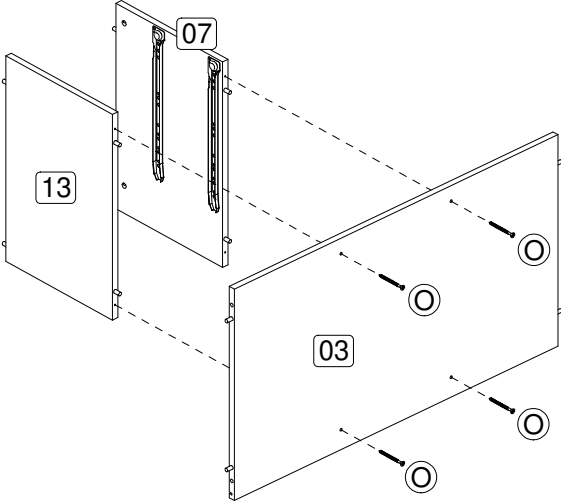

Step 4: Attach the base panel (3) and the plinths (4) to the right panel (8) using hardware parts L and M with a screwdriver (not provided).

DO NOT use any power tools as this may damage the frame and will invalidate any claim.

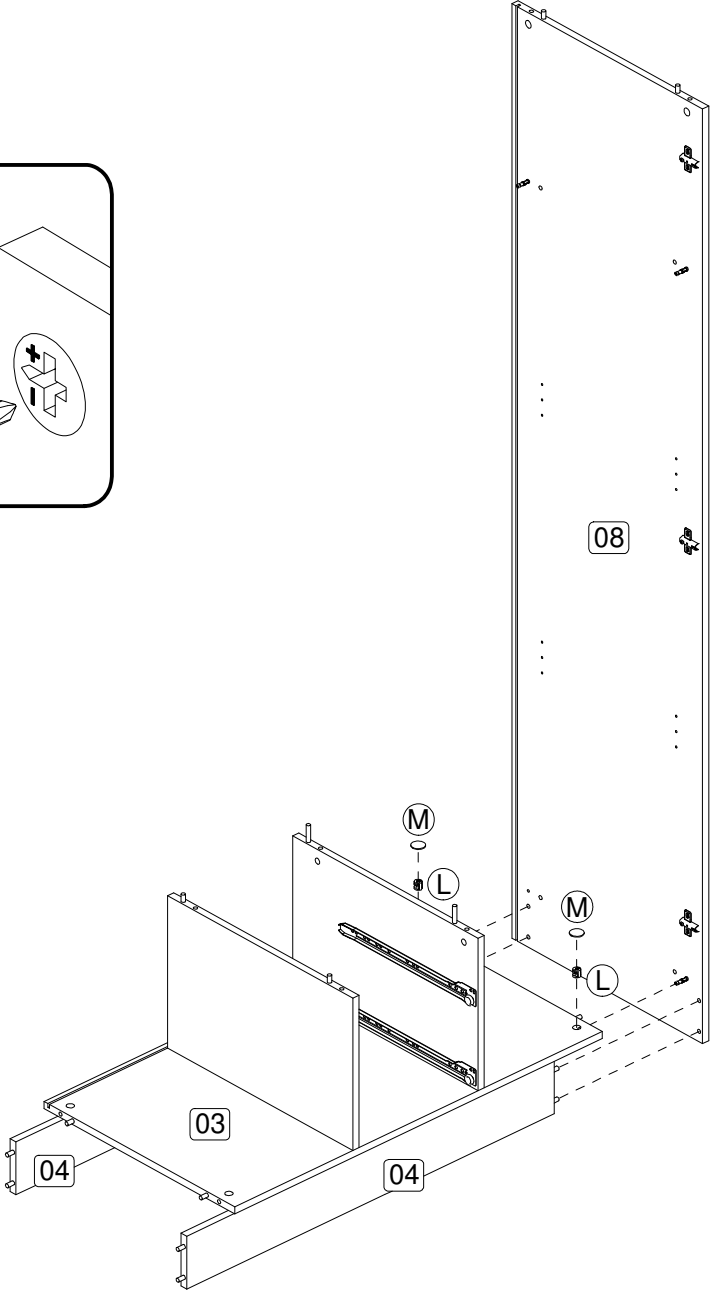
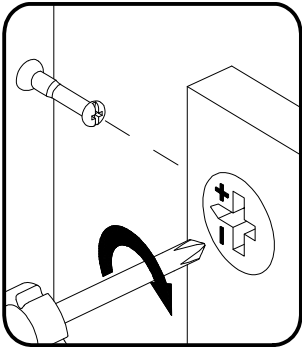

Step 5: Attach the drawer cabinet top panel (12) using hardware parts K and L. Attach the front support (21) and back support (11) using hardware parts L and M. You will need to use a screwdriver (not provided). **DO NOT use any power tools as this may damage the frame and will invalidate any claim.**

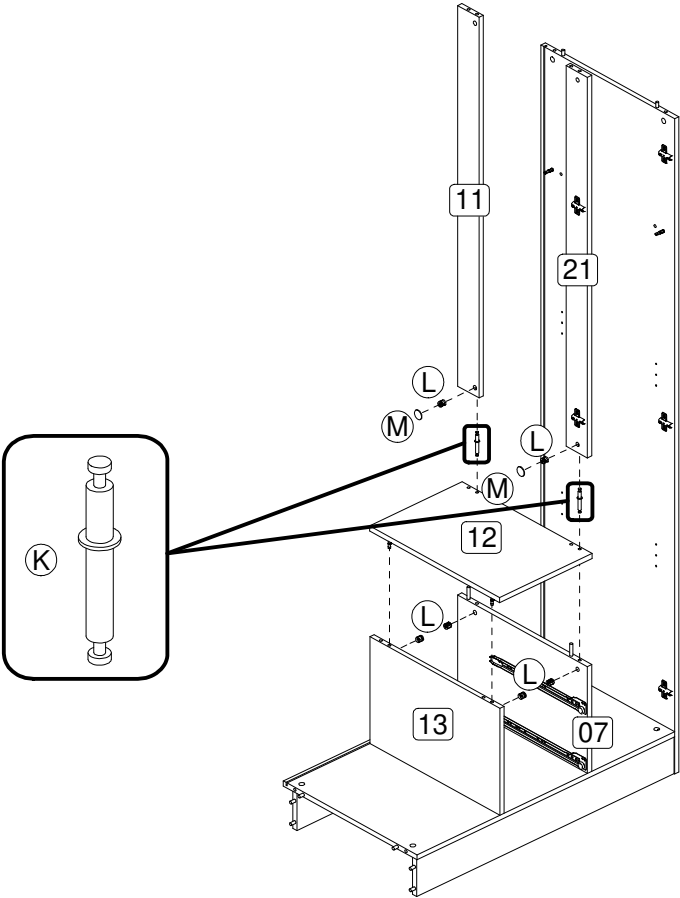

Step 6: Attach the shelf (2) using hardware parts L and M with a screwdriver (not provided). **DO NOT use any power tools as this may damage the frame and will invalidate any claim.**

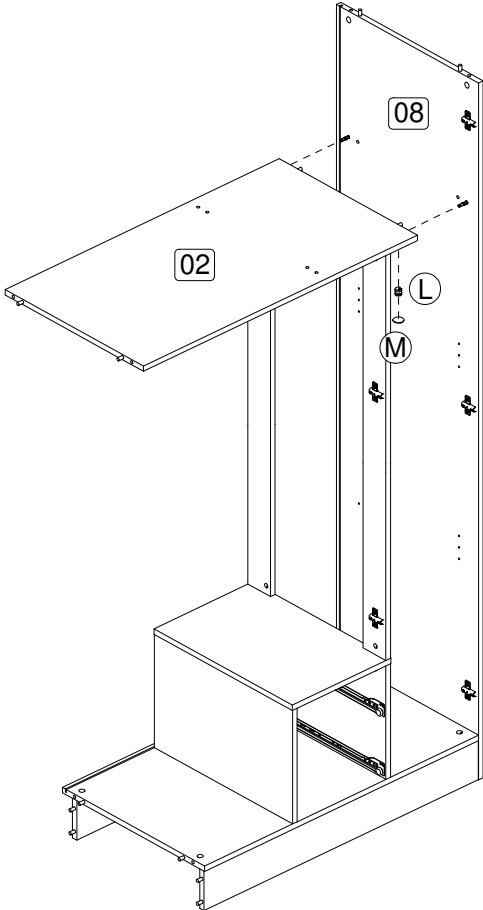

Step 7: Secure the shelf (2) to the back support (11) and front support (21) using hardware parts K, L and M. Fix the shelf divider (6) to the shelf (2) using hardware parts L and M. You will need to use a screwdriver (not provided).

DO NOT use any power tools as this may damage the frame and will invalidate any claim.

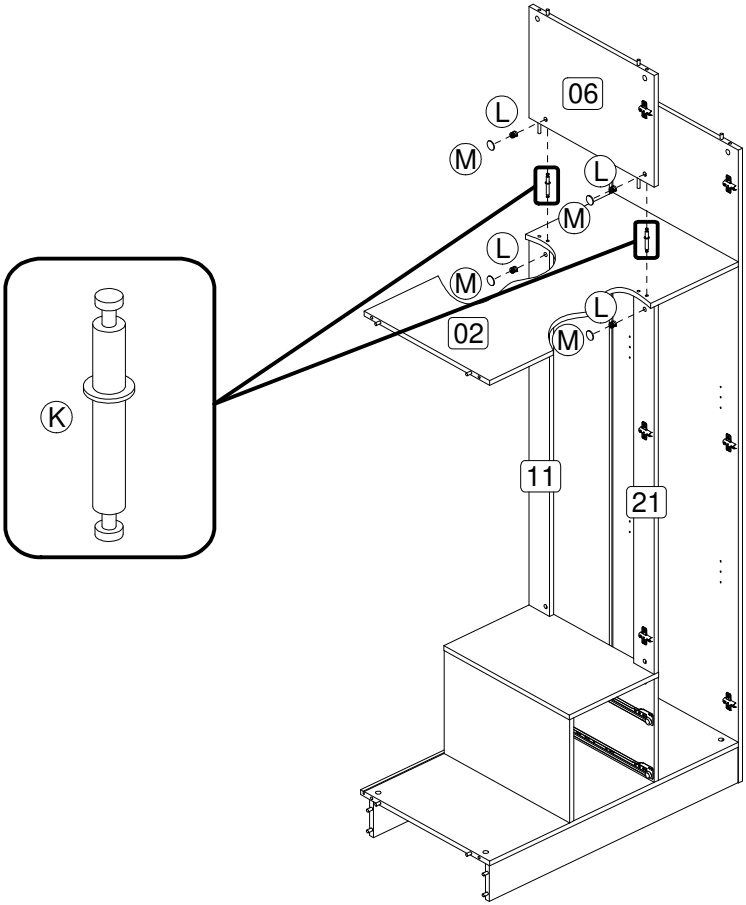

Step 8: Attach the left panel (5) using hardware parts L and M with a screwdriver (not provided). **DO NOT use any power tools as this may damage the frame and will invalidate any claim.**

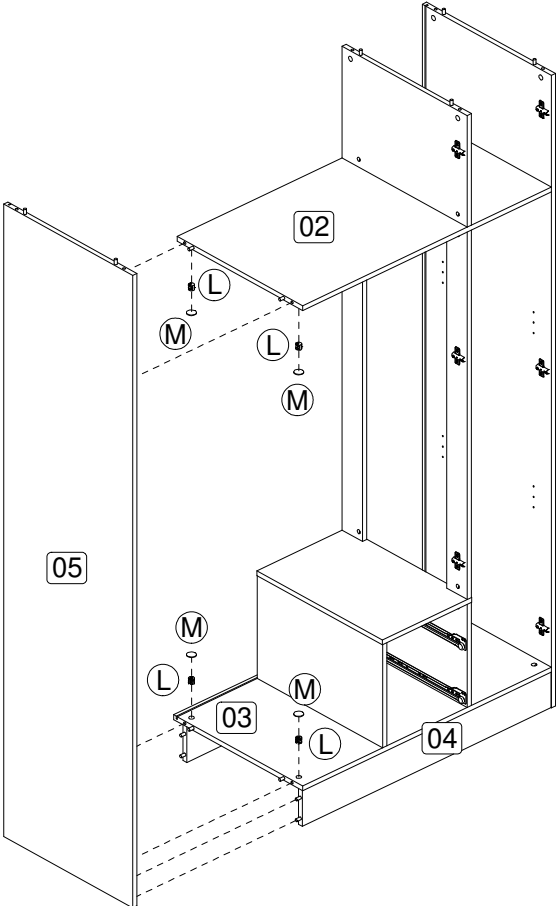

Step 9: Connect two back panels (10) using the spine A6 then position all back panels. Attach the top panel (1) using hardware parts L and M. Insert the shelves (20) using hardware parts P5 and W8. **DO NOT use any power tools as this may damage the frame and will invalidate any claim.**

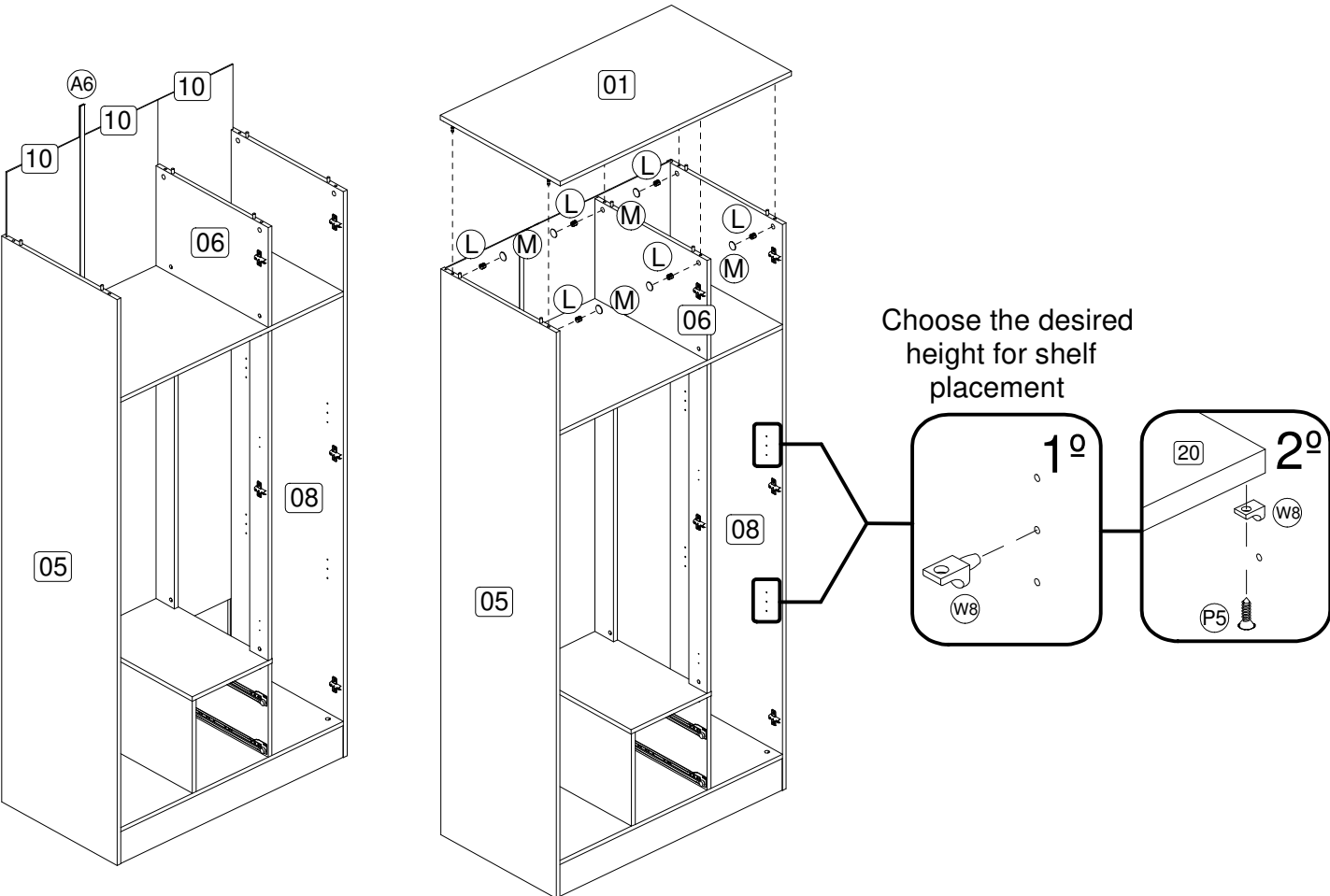

Step 10: Secure the back panels (10) using hardware parts C1 and N with a small mallet (not provided) then position the hanging rail R4. **DO NOT use any power tools as this may damage the frame and will invalidate any claim.**

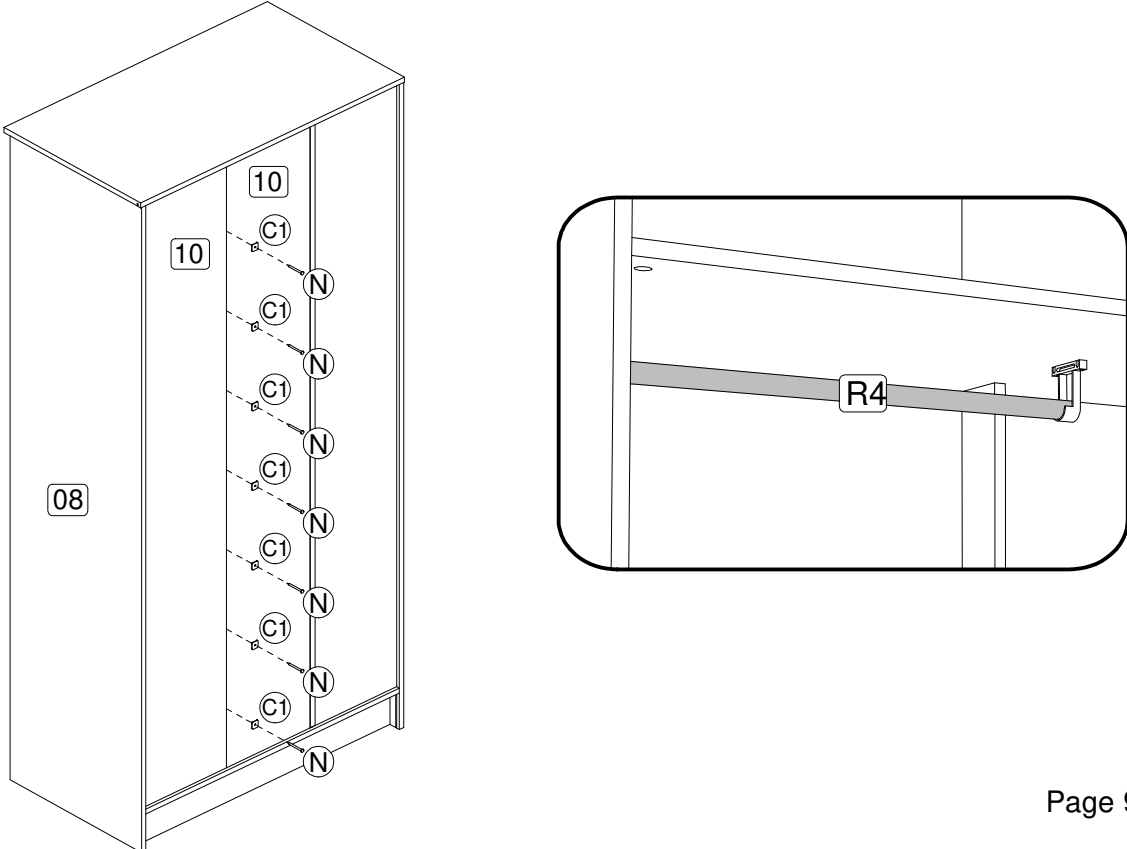

Step 11: Attach the doors (9) and the mirrored door (19) then attach the handles W2 using hardware part T. You will need to use a screwdriver (not provided). **DO NOT use any power tools as this may damage the frame and will invalidate any claim.**

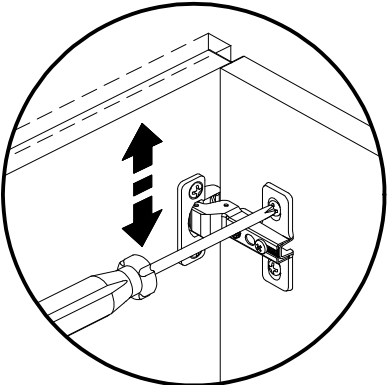
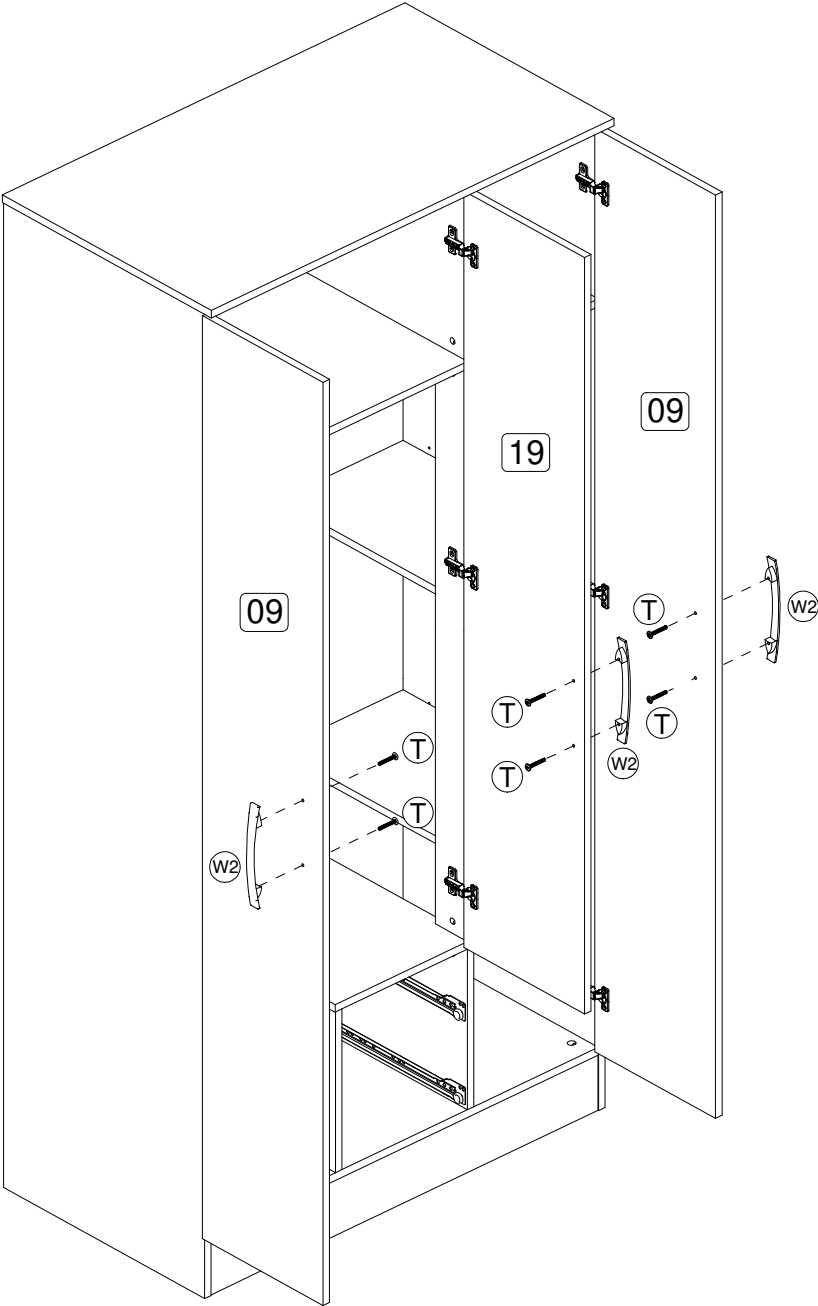

Vertical Adjustment

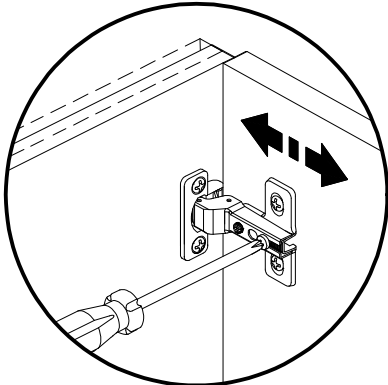

Depth Adjustment

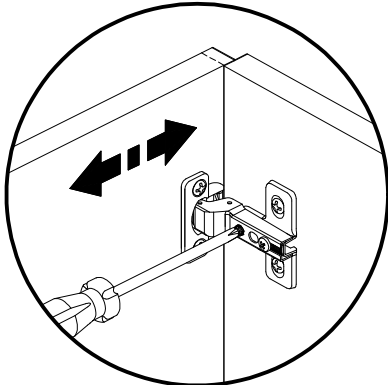

Horizontal Adjustment

Step 12: Assemble the drawer components using hardware parts A1, L, M, O, P5, W2, WC and WD with a screwdriver (not provided).

DO NOT use any power tools as this may damage the frame and will invalidate any claim.

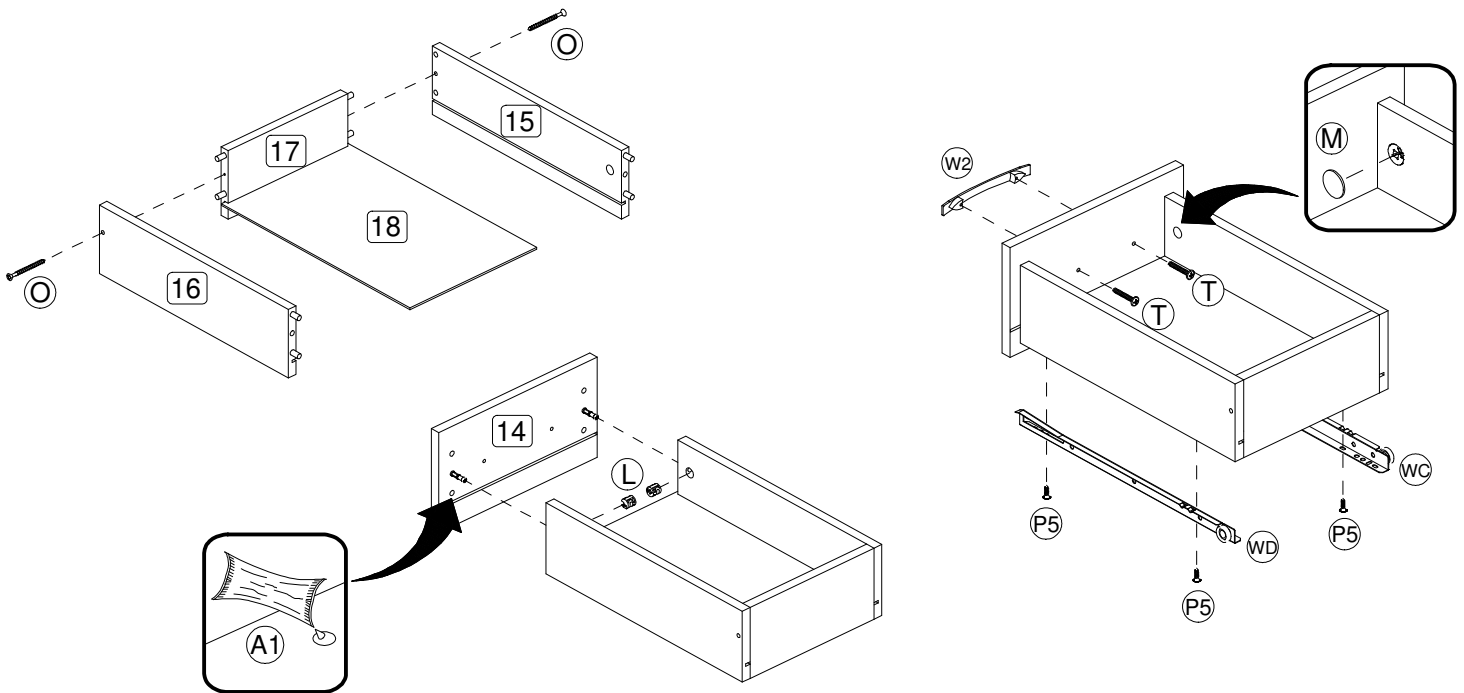

Step 13: To secure the item to the wall use hardware parts A, B3 and E9 using a screwdriver (not provided). Then attach hardware part S to the item with a screwdriver (not provided).

DO NOT use any power tools as this may damage the frame and will invalidate any claim.

Birlea Furniture advise you use the wall straps provided to further enhance the safety of this product.

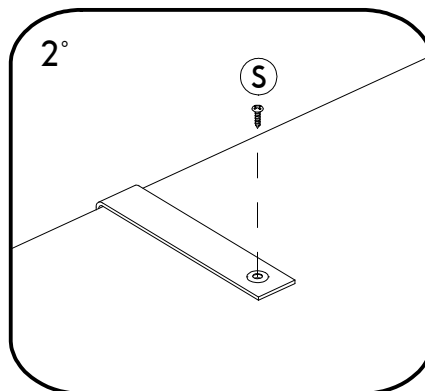
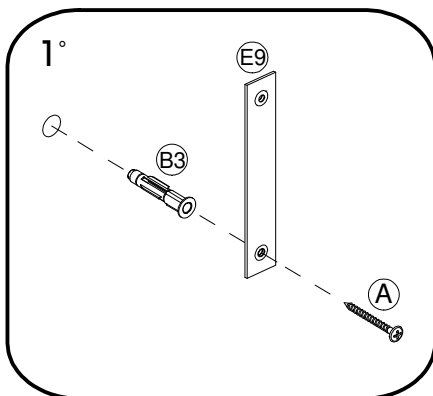

Additional Information:

- For complete product information, images and dimension diagrams please visit the website www.birlea.com
- If you have any issues with your item please contact the retailer directly you purchased it from who will be able to resolve any issues with Birlea.
- Why don't you send us photos of your assembled furniture to info@birlea.com to be shared in our #birleahome feature on Instagram.



Birlea

Suppliers of inspiration