

WHITE / OAK EFFECT PORTLAND 3+2 DRAWER CHEST ASSEMBLY INSTRUCTIONS

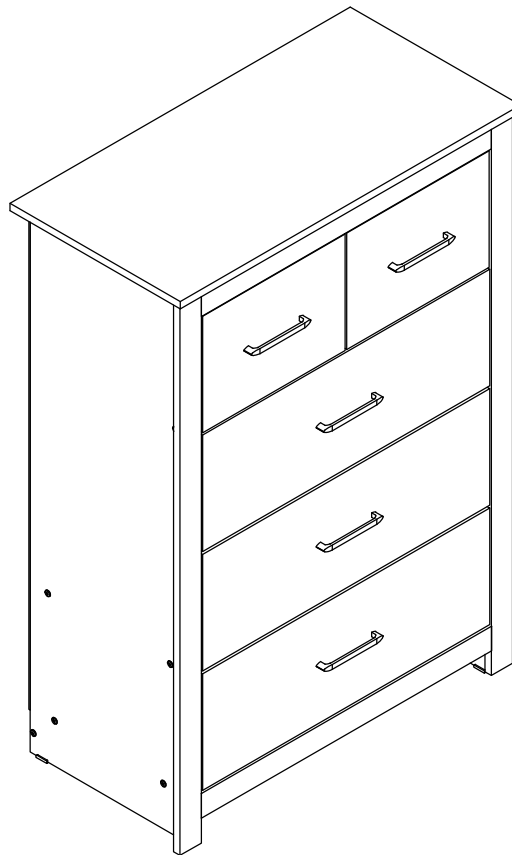
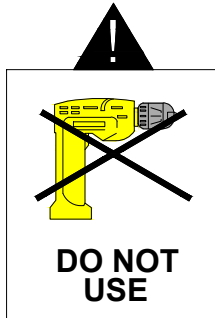

IMPORTANT FOR DOMESTIC USE ONLY PLEASE READ BEFORE YOU CONTINUE FURTHER

THE PRODUCT YOU HAVE PURCHASED WILL GIVE YOU MANY YEARS OF SERVICE IF YOU FOLLOW THE GUIDELINES FOR ITS SAFE ASSEMBLY AND PERIODIC MAINTENANCE AND CLEANING.

ASSEMBLE ON A SOFT CLEAN SURFACE.

DO NOT USE ANY TOOLS OTHER THAN THOSE SHOWN.

ANY SPANNERS OR ALLEN KEYS REQUIRED ARE INCLUDED WITH THE FITTINGS KIT.

DO NOT FOR ANY REASON USE A POWER TOOL TO ASSEMBLE THIS PRODUCT. ITS USE WILL INVALIDATE ANY CLAIM YOU MAY HAVE AND COULD MAKE THIS PRODUCT UNSAFE.

DEPENDING ON THE AMOUNT OF USE THIS PRODUCT RECEIVES IT MAY BE NECESSARY TO TIGHTEN UP THE FIXINGS FROM TIME TO TIME. THIS IS COMPLETELY NORMAL FOR ANY FLAT PACK FURNITURE. DO NOT OVERTIGHTEN FIXING.

FOR CLEANING, YOU MAY USE A DAMP CLOTH (NOT WET) DO NOT USE POLISH, DETERGENT OR CHEMICAL CLEANERS.



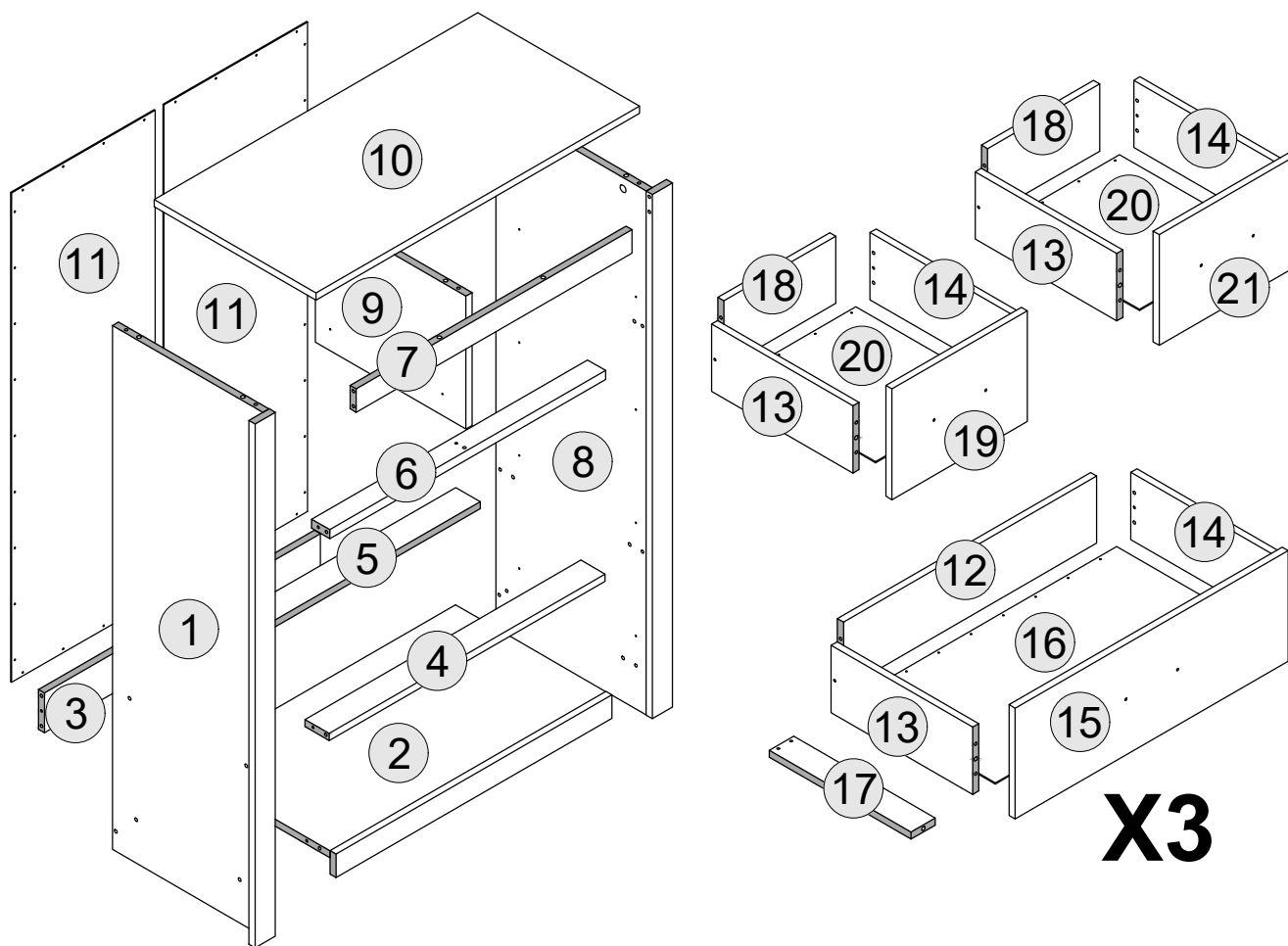









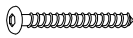



THE SURFACE OF THIS ITEM IS NOT HEAT RESISTANT. ALWAYS USE A PLACE MAT UNDER HOT OR COLD ITEMS TO PREVENT MARKING.

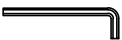
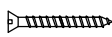
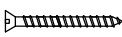

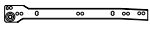
PART LIST

Part Number	Part Code	Part Description	Quantity	Carton
1	S100-102-181-EU1-01	Side Panel - Left	1	1/2
2	S100-102-181-EU1-02	Bottom Panel	1	2/2
3	S100-102-181-EU1-03	Base Apron	1	2/2
4	S100-102-181-EU1-04	Front Crossbar	1	2/2
5	S100-102-181-EU1-05	Back Crossbar	1	2/2
6	S100-102-181-EU1-06	Support Centre	1	2/2
7	S100-102-181-EU1-07	Top Frame	1	2/2
8	S100-102-181-EU1-08	Side Panel - Right	1	1/2
9	S100-102-181-EU1-09	Centre Panel	1	2/2
10	S100-102-181-EU1-10	Top Panel	1	2/2
11	S100-102-181-EU1-11	Back Panel	2	1/2
12	S100-102-181-EU1-12	Large Drawer Back	3	2/2
13	S100-102-181-EU1-13	Drawer Side - Left	5	1/2
14	S100-102-181-EU1-14	Drawer Side - Right	5	1/2
15	S100-102-181-EU1-15	Large Drawer Front	3	2/2
16	S100-102-181-EU1-16	Large Drawer Base	3	1/2
17	S100-102-181-EU1-17	Drawer Base Support Rail	3	1/2
18	S100-102-181-EU1-18	Small Drawer Back	2	1/2
19	S100-102-181-EU1-19	Small Drawer Front - Left	1	1/2
20	S100-102-181-EU1-20	Small Drawer Base	2	2/2
21	S100-102-181-EU1-21	Small Drawer Front - Right	1	1/2

HARDWARE LIST

A		DOWEL 6 X 30MM	67 PCS
B		CAM BOLT + CAM NUT	21 SETS
C		BOLT M6 X 50MM	12 PCS
D		SCREW M3.5 X 16MM	34 PCS
E		TACK	34 PCS
F		PLASTIC FOOT	4 PCS
G		SCREW M3.5 X 12MM	72 PCS
H		SCREW M4 X 30MM	6 PCS
I		ALLEN KEY	1 PC
J		SCREW M4 X 38MM	10 PCS
K		SCREW M4 X 50MM	1 PC
L		PLASTIC H STRIP	1 PC
M		DRAWER RUNNER A - L/R	10 PCS
N		DRAWER RUNNER B - L/R	10 PCS
O		HANDLE	5 PCS
P		HANDLE SCREW 20MM	10 PCS
Q		ANTI - TIP STRAP	2 PCS
R		SCREW M4 X 16MM	2 PCS

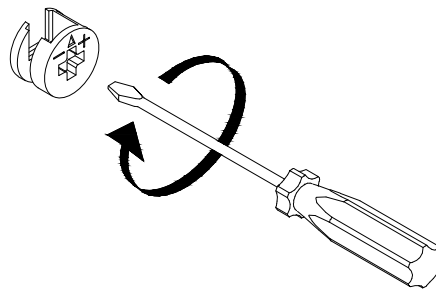

(SCREWDRIVER NOT PROVIDED)

USE A FLAT HEAD SCREWDRIVER TO TIGHTEN THE CAM NUTS. A QUARTER TURN CLOCKWISE IS ALL THAT IS NEEDED.

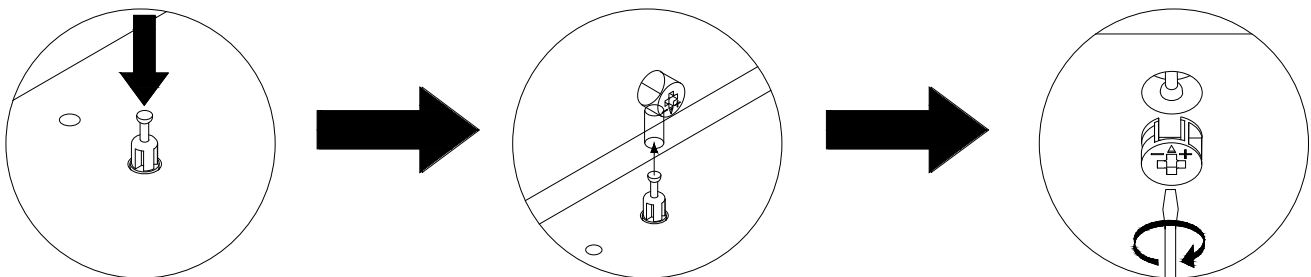

STEP 1 - PUSH CAM BOLT INTO INSERT

STEP 2 - ALIGN THE CAM BOLT WITH THE HOLE AND PUSH TOGETHER UNTIL FLUSH. (MAKE SURE THE ARROW OF THE CAM LOCK IS POINTING TOWARD THE EDGE OF THE PANEL.)

STEP 3 - THE HEAD OF THE BOLT GOES INTO THE WIDE MOUTH OF THE CAM LOCK. YOU THEN TURN THE LOCK SO THE NARROW PART CLOSES OVER THE BOLT.

STEP 1

PARTS REQUIRED

1 - SIDE PANEL - LEFT x1

HARDWARE REQUIRED

A  02

B  02

G  16

M  04

TOOLS REQUIRED

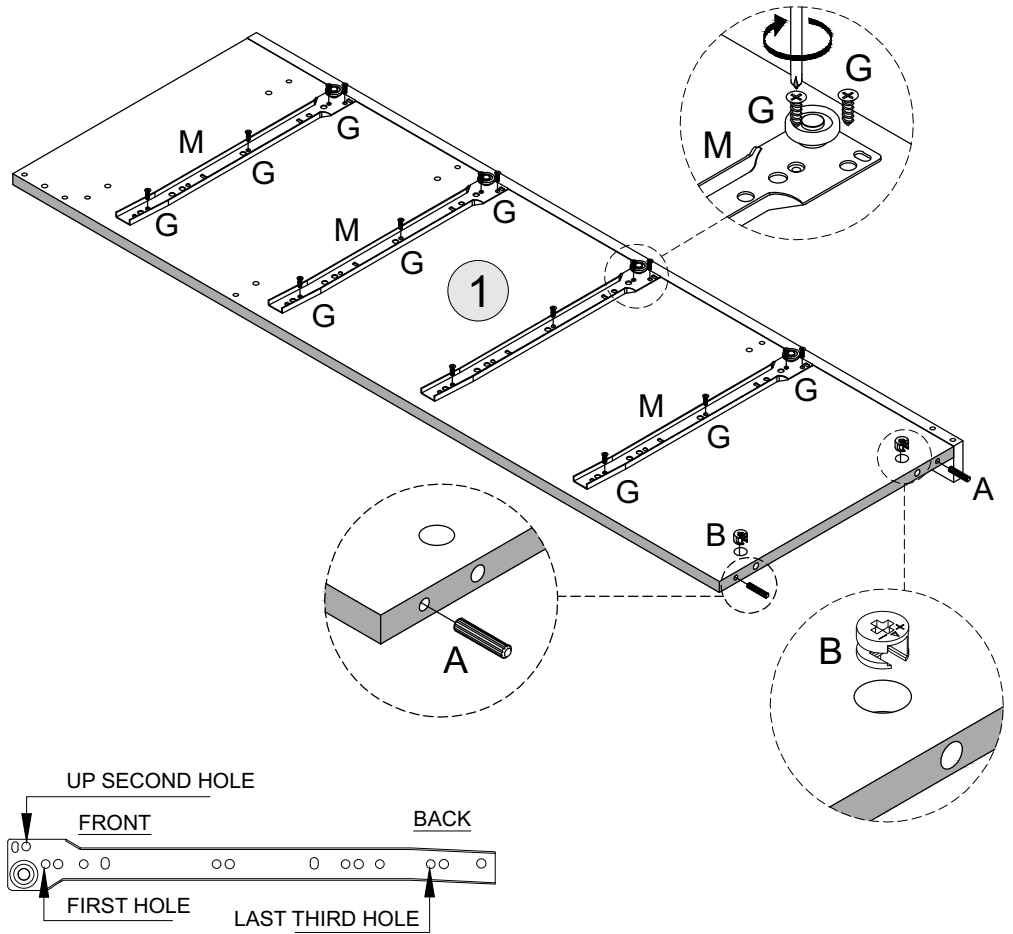
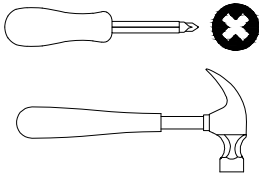

STEP 2

PARTS REQUIRED

8 - SIDE PANEL - RIGHT x1

HARDWARE REQUIRED

A  02

B  02

G  16

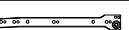
M  04

TOOLS REQUIRED

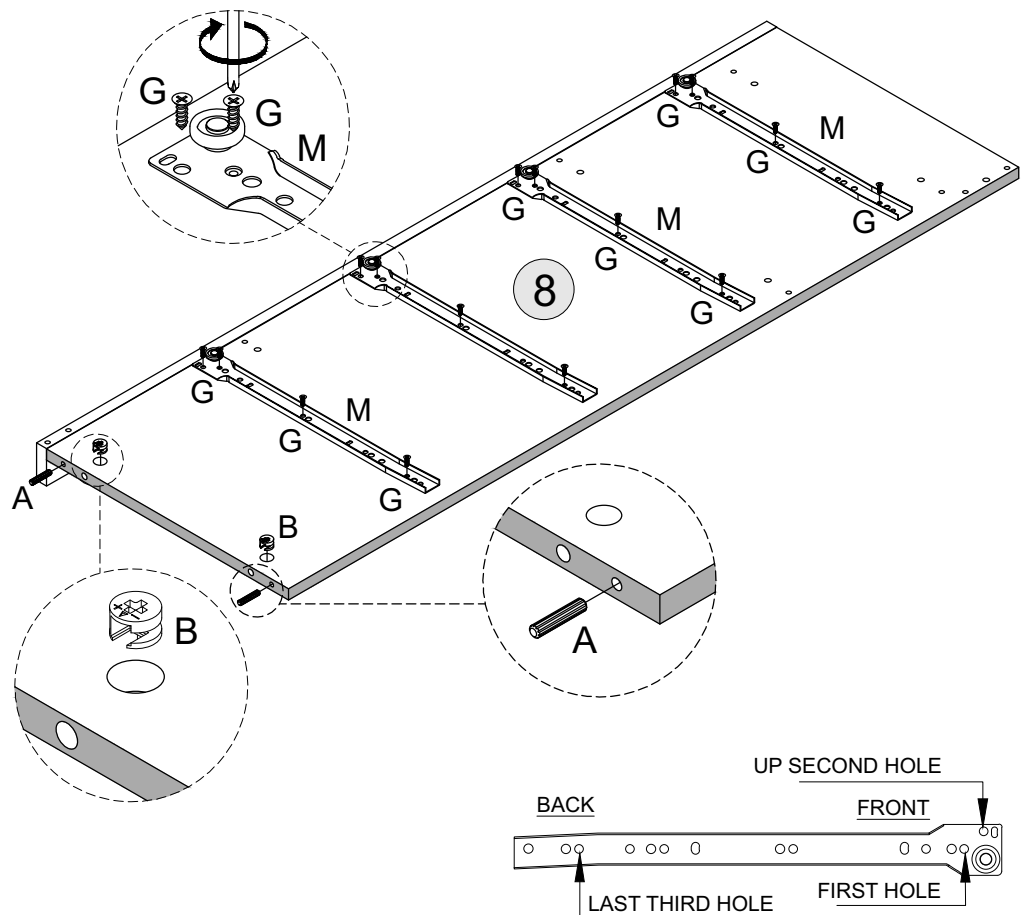
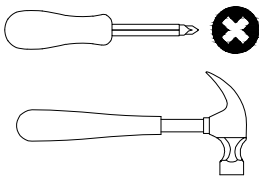

STEP 5

PARTS REQUIRED

2 - BOTTOM PANEL x1

10 - TOP PANEL x1

HARDWARE REQUIRED

A  04

B  08

TOOLS REQUIRED

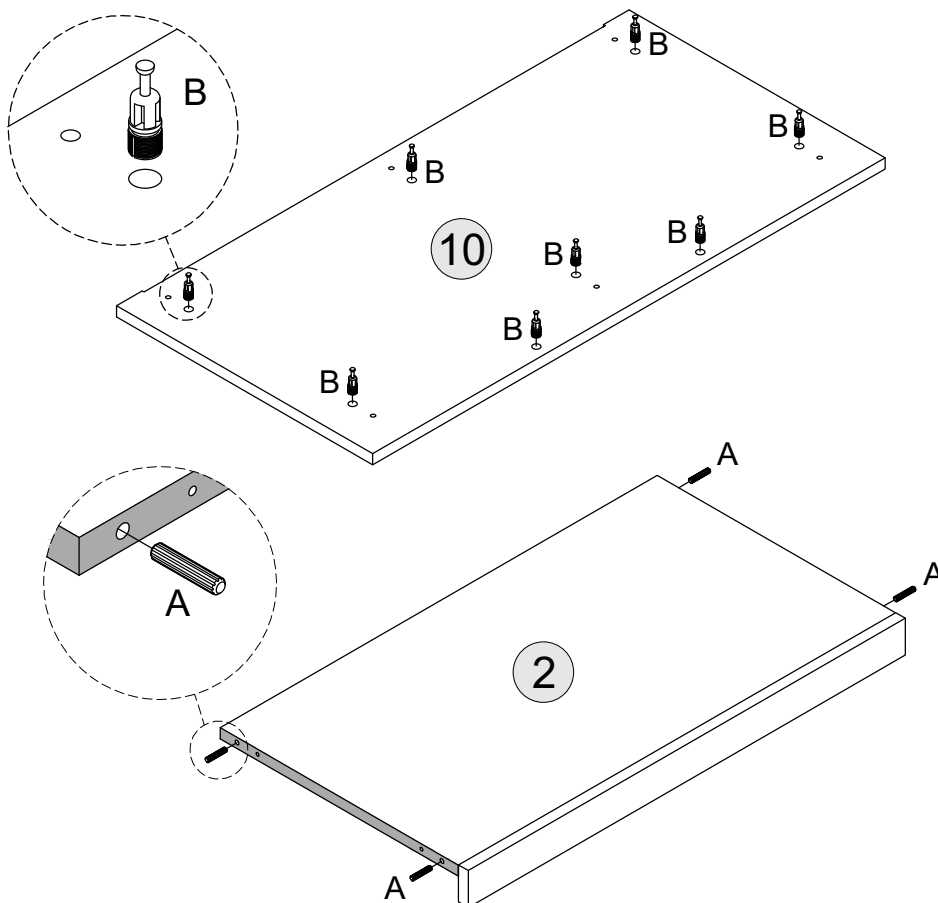
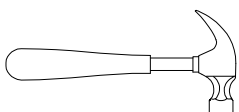

STEP 6

PARTS REQUIRED

2 - BOTTOM PANEL x1

3 - BASE APRON x1

HARDWARE REQUIRED

TOOLS REQUIRED

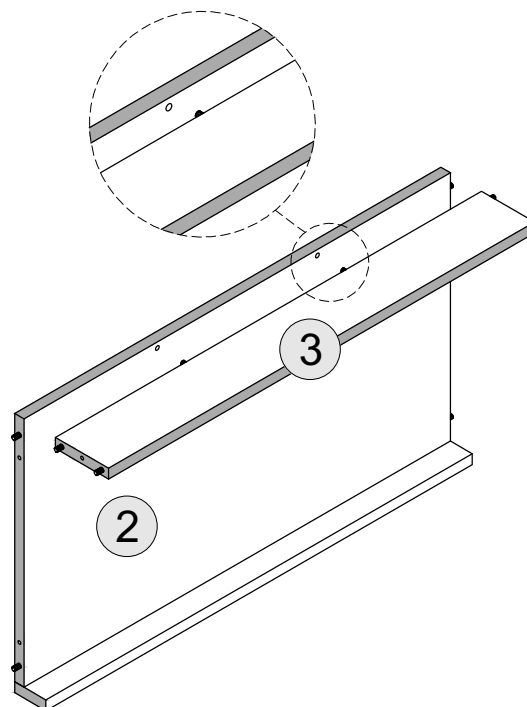

STEP 7

PARTS REQUIRED

1 - SIDE PANEL - LEFT x1

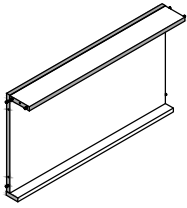

HARDWARE REQUIRED

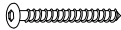
C  03

TOOLS REQUIRED

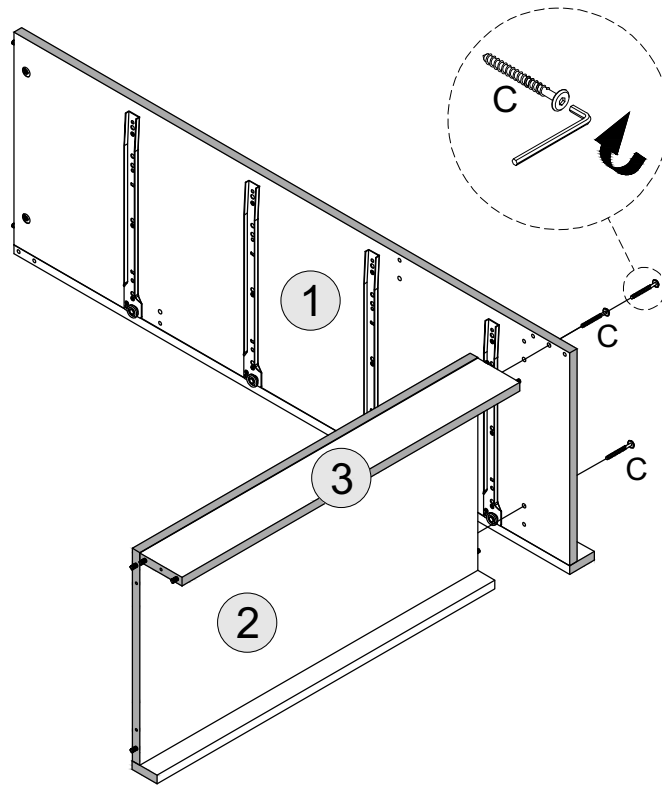

STEP 8

PARTS REQUIRED

4 - FRONT CROSBAR x1

5 - BACK CROSSBAR x1

6 - SUPPORT CENTRE x1

7 - TOP FRAME x1

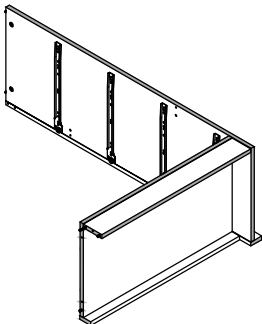

HARDWARE REQUIRED

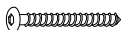
C  03

TOOLS REQUIRED

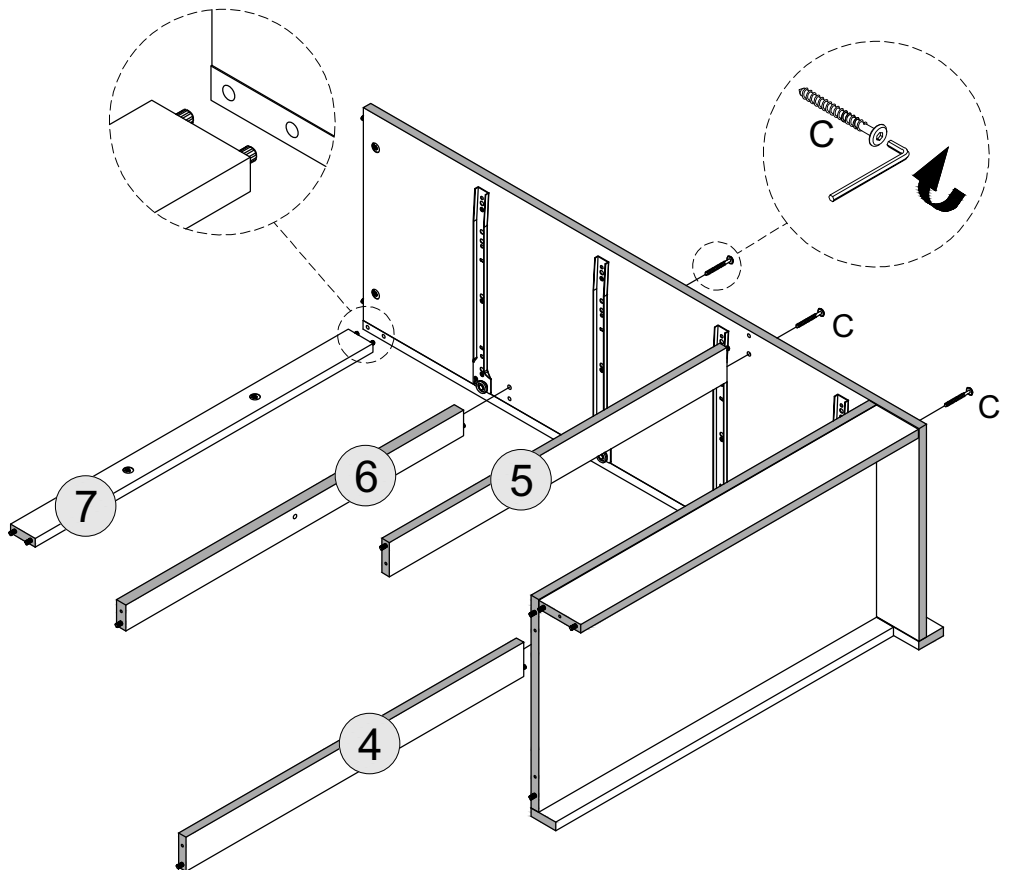

STEP 9

PARTS REQUIRED

8 - SIDE PANEL - RIGHT x1

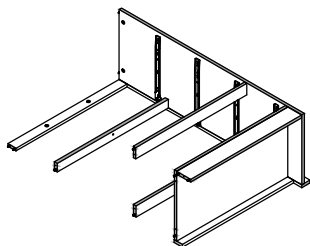

HARDWARE REQUIRED

C  06

TOOLS REQUIRED

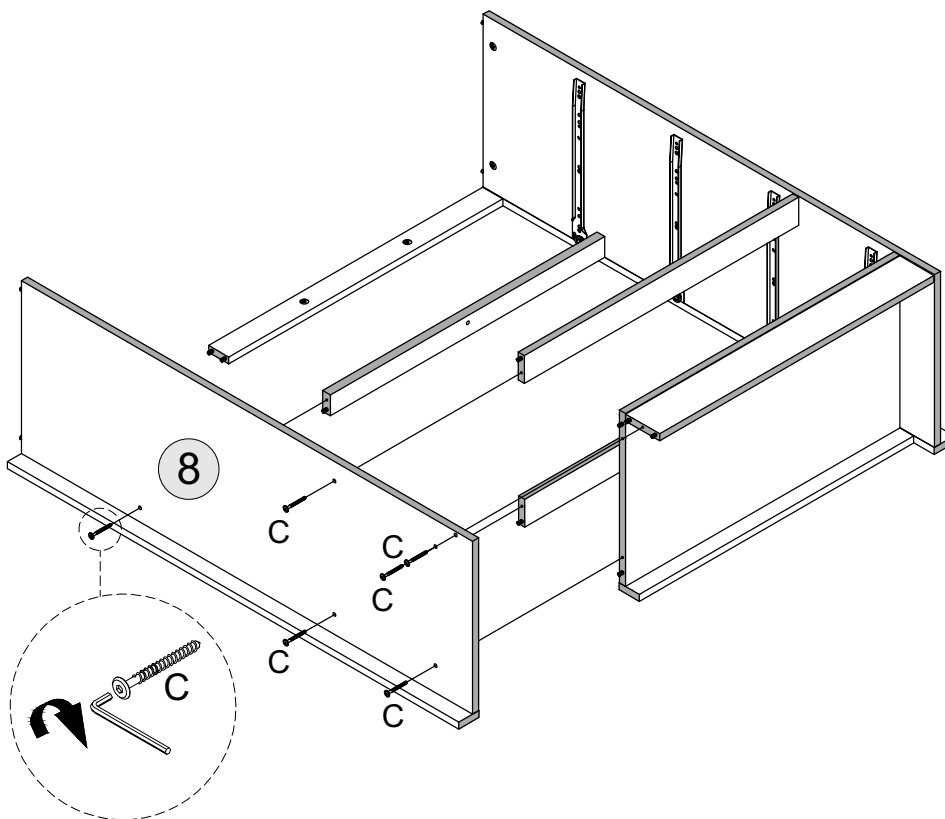

STEP 10

PARTS REQUIRED

9 - CENTRE PANEL x1

10 - TOP PANEL x1

HARDWARE REQUIRED

TOOLS REQUIRED

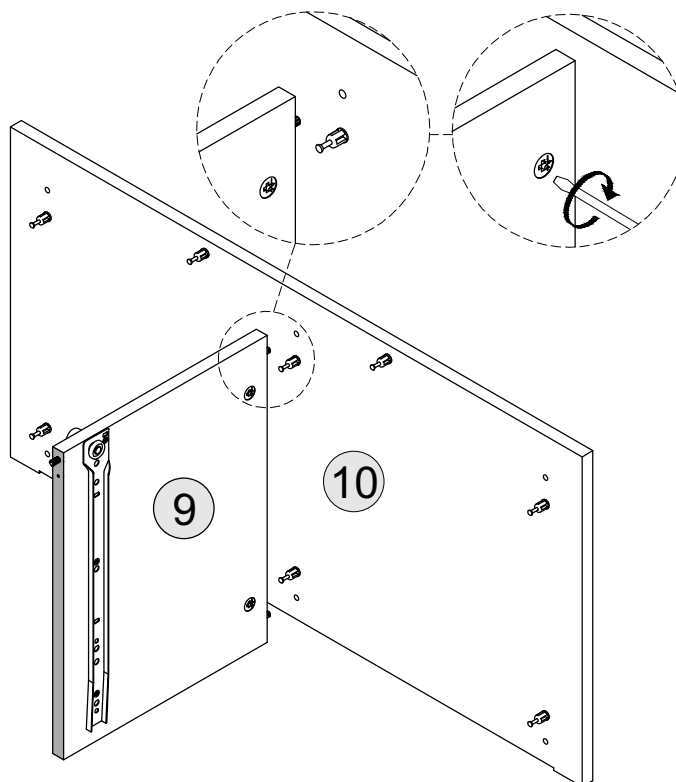

STEP 11

PARTS REQUIRED

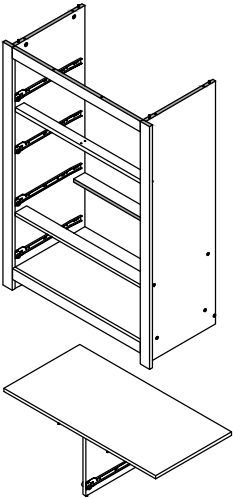

HARDWARE REQUIRED

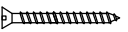
K  01

TOOLS REQUIRED

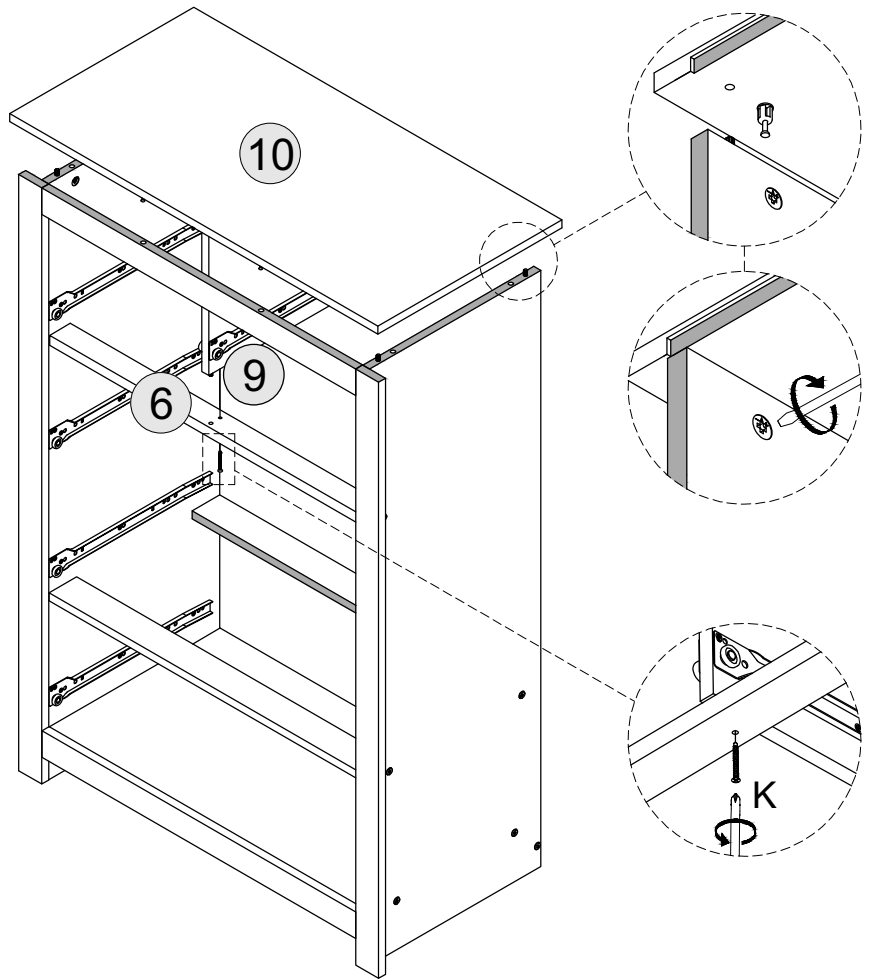
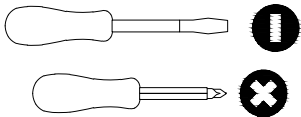

STEP 12

PARTS REQUIRED

11 - BACK PANEL x2

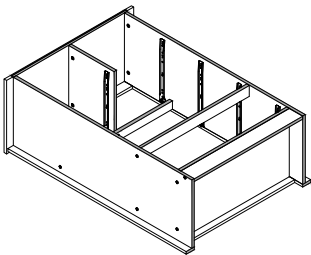

HARDWARE REQUIRED

D  04

E  34

F  04

L  01

TOOLS REQUIRED

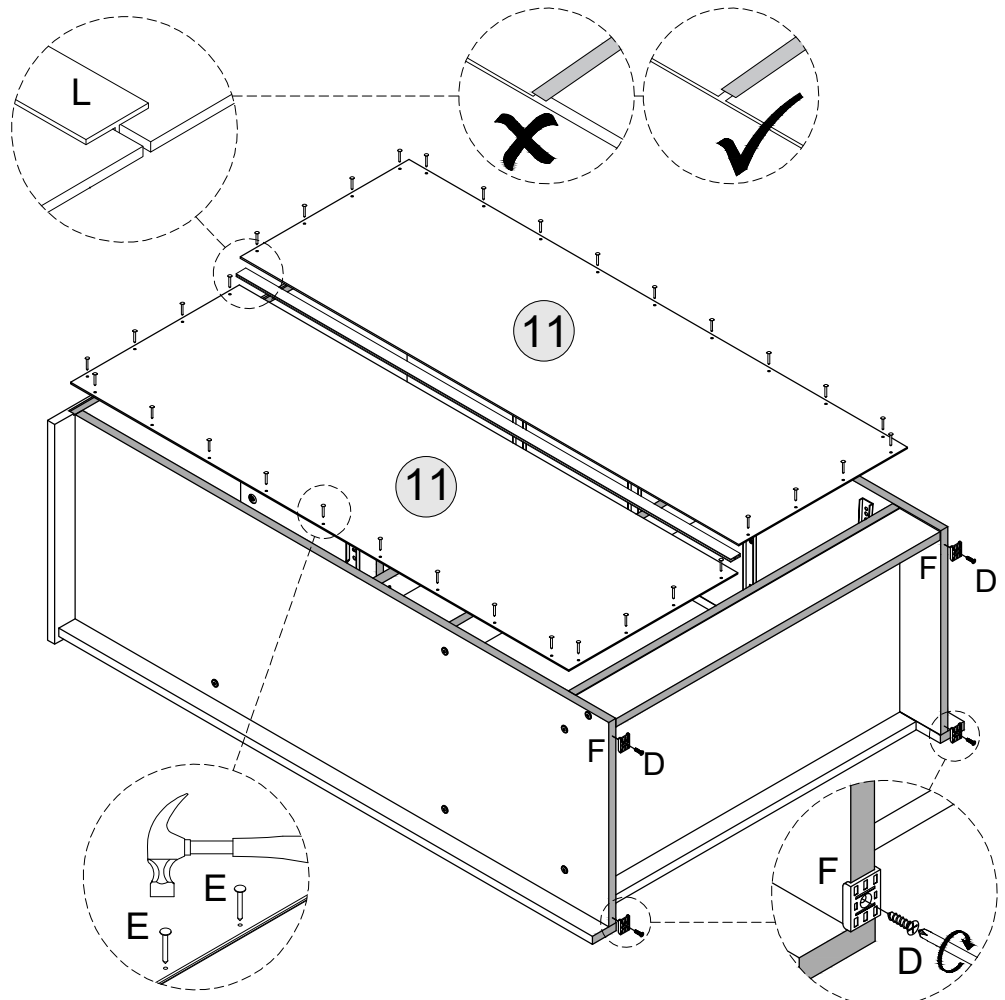
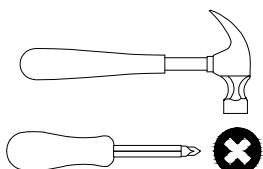



STEP 13

PARTS REQUIRED

- 12 - LARGE DRAWER BACK x3
- 13 - DRAWER SIDE-LEFT x3
- 14 - DRAWER SIDE-RIGHT x3
- 15 - LARGE DRAWER FRONT x3

HARDWARE REQUIRED

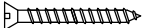
- | | | |
|---|---|----|
| A |  | 24 |
| B |  | 09 |
| B |  | 06 |
| J |  | 06 |

TOOLS REQUIRED

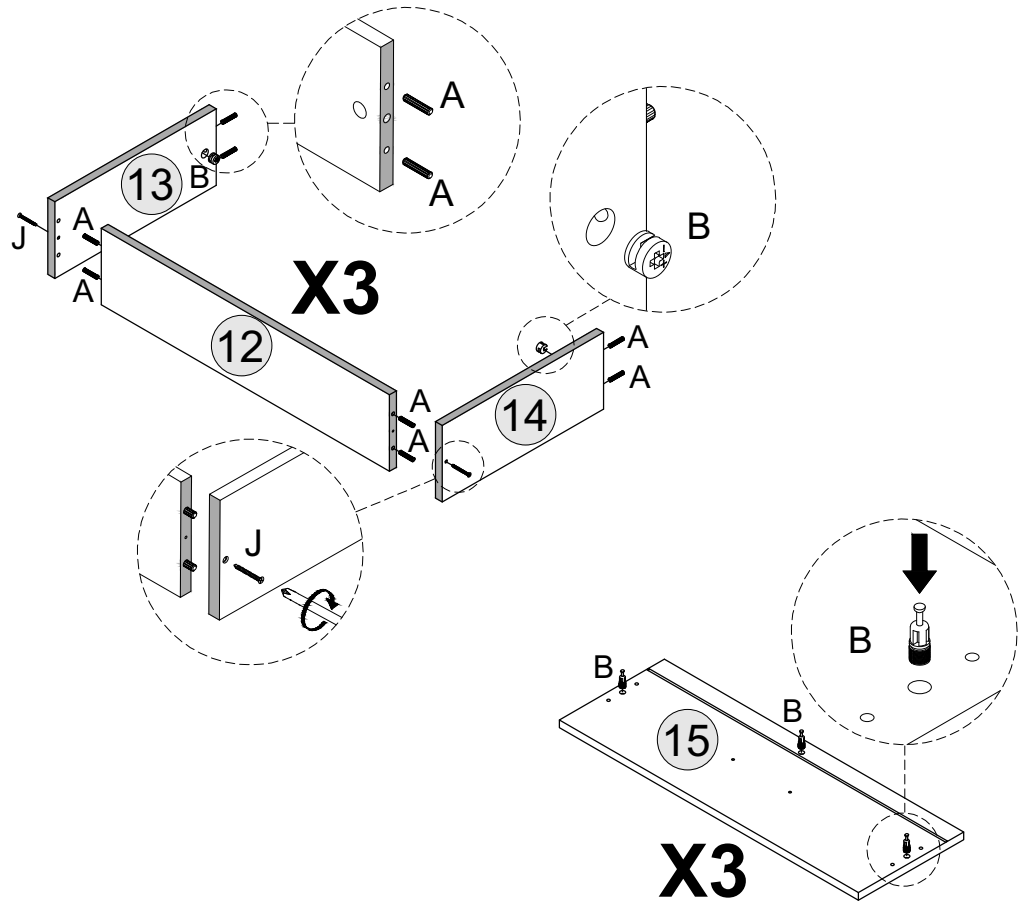
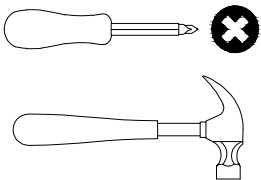



STEP 14

PARTS REQUIRED

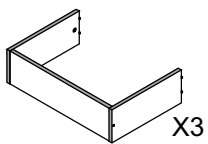
- 15 - LARGE DRAWER FRONT x3
- 16 - LARGE DRAWER BASE x3



HARDWARE REQUIRED

- | | | |
|---|---|----|
| G |  | 24 |
| O |  | 03 |
| P |  | 06 |

TOOLS REQUIRED

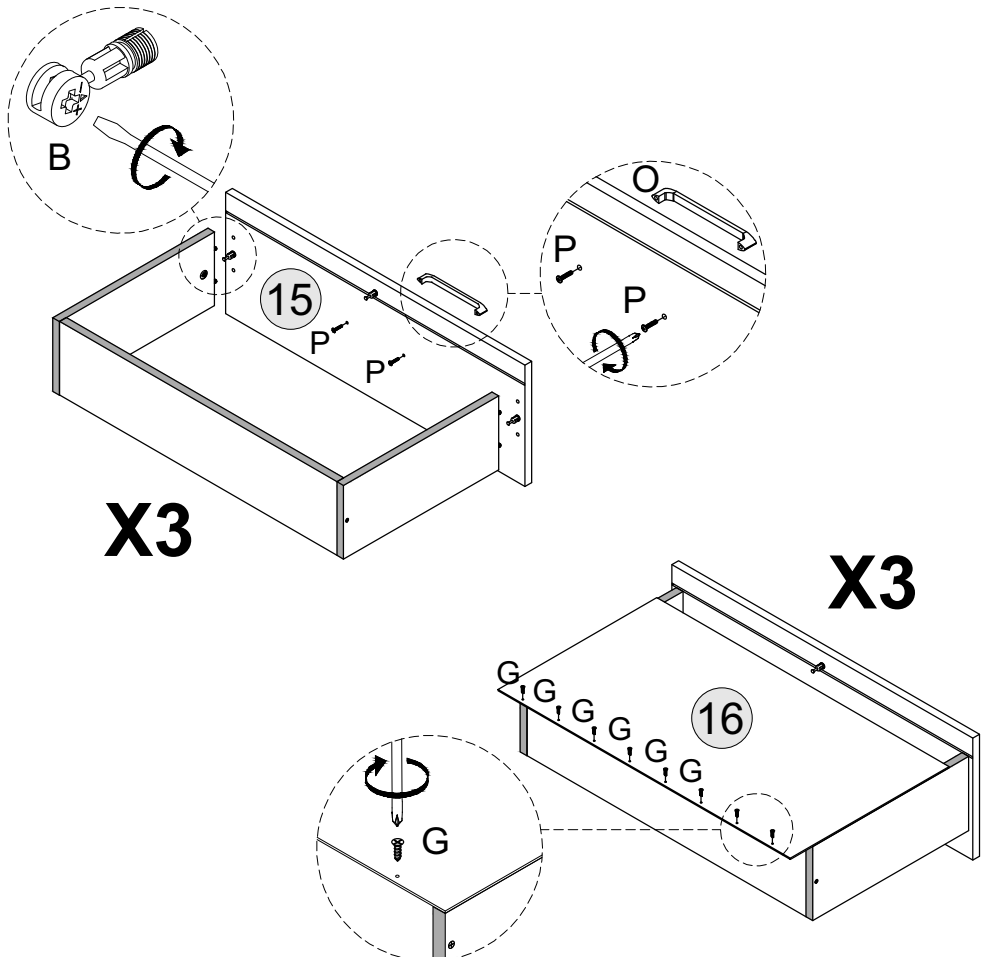
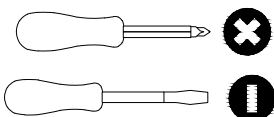

STEP 15

PARTS REQUIRED

17 - DRAWER BASE SUPPORT RAIL x3

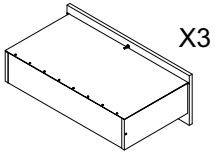

HARDWARE REQUIRED

B  03

D  18

H  06

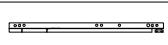
N  06

TOOLS REQUIRED

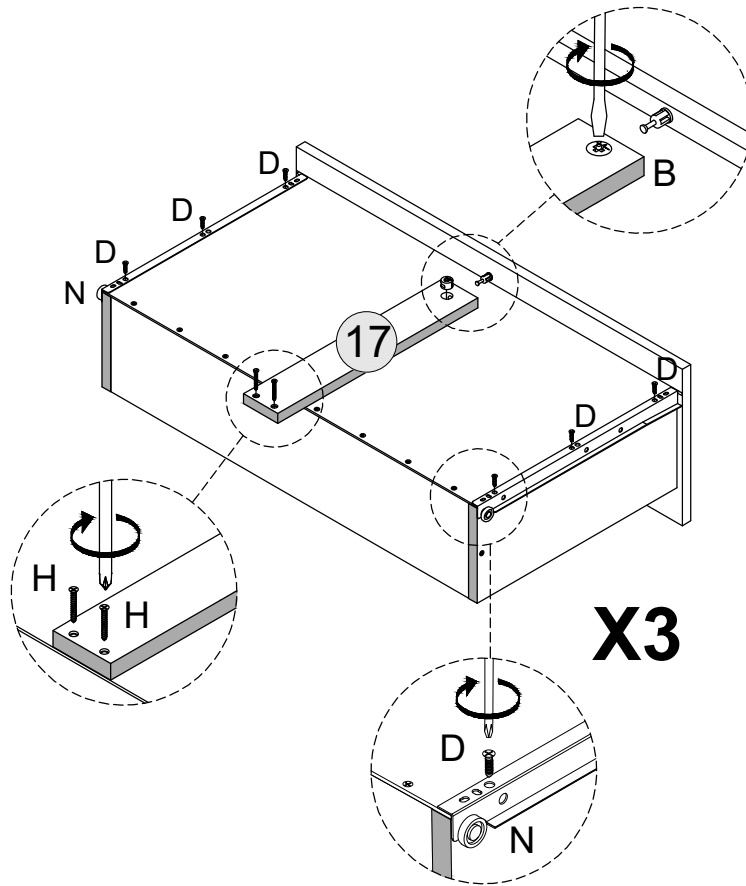
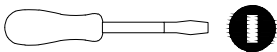
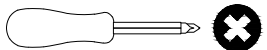

STEP 16

PARTS REQUIRED

13 - DRAWER SIDE-LEFT x2

14 - DRAWER SIDE-RIGHT x2

18 - SMALL DRAWER BACK x2

19 - SMALL DRAWER FRONT-LEFT x1

21 - SMALL DRAWER FRONT-RIGHT x1

HARDWARE REQUIRED

A  16

B  04

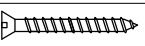
J  04

TOOLS REQUIRED

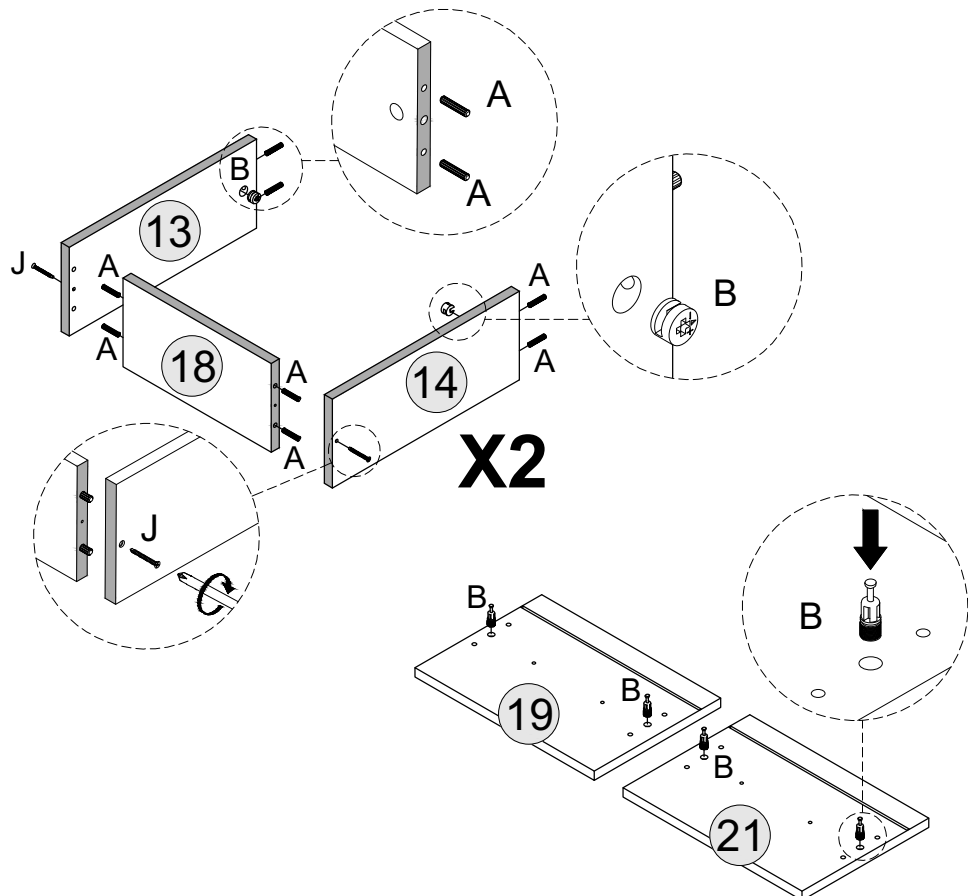
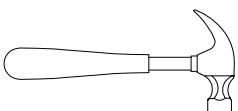
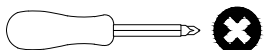

STEP 17

PARTS REQUIRED

19 - SMALL DRAWER FRONT - LEFT x2

21 - SMALL DRAWER FRONT - RIGHT x2

23 - SMALL DRAWER BASE x2

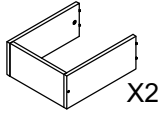

HARDWARE REQUIRED

G  08

O  02

P  04

TOOLS REQUIRED

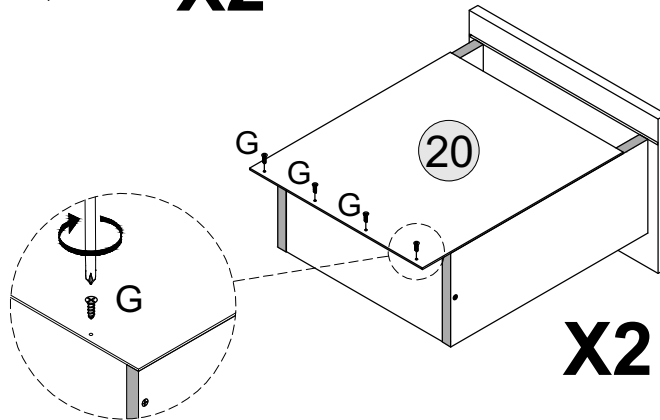
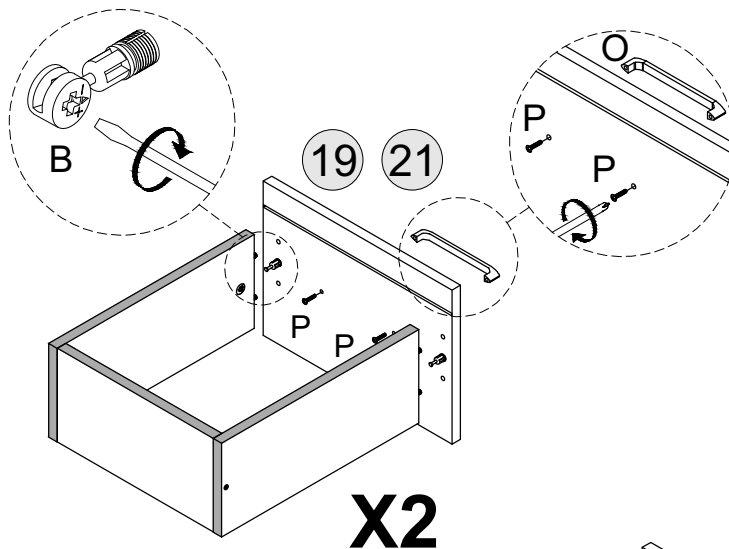
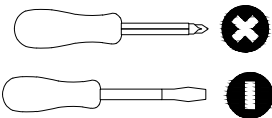

STEP 18

PARTS REQUIRED

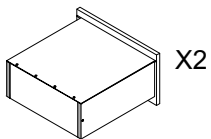

HARDWARE REQUIRED

D  12

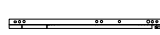
N  04

TOOLS REQUIRED

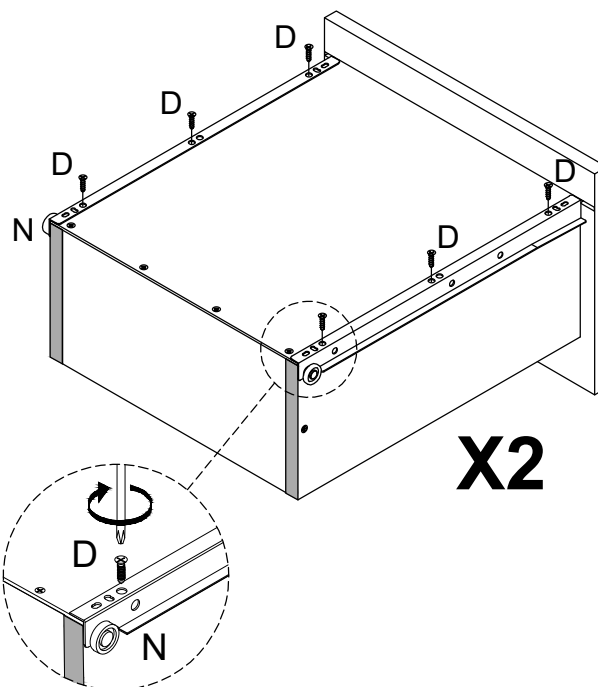
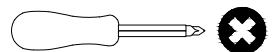

STEP 19

PARTS REQUIRED

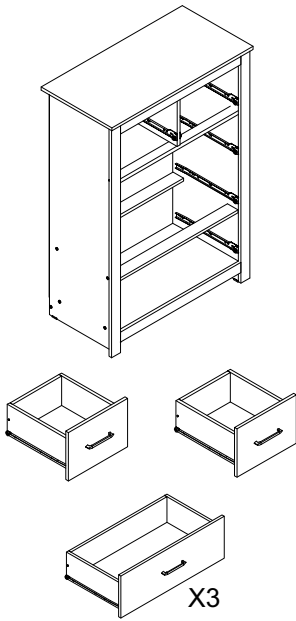

HARDWARE REQUIRED

TOOLS REQUIRED

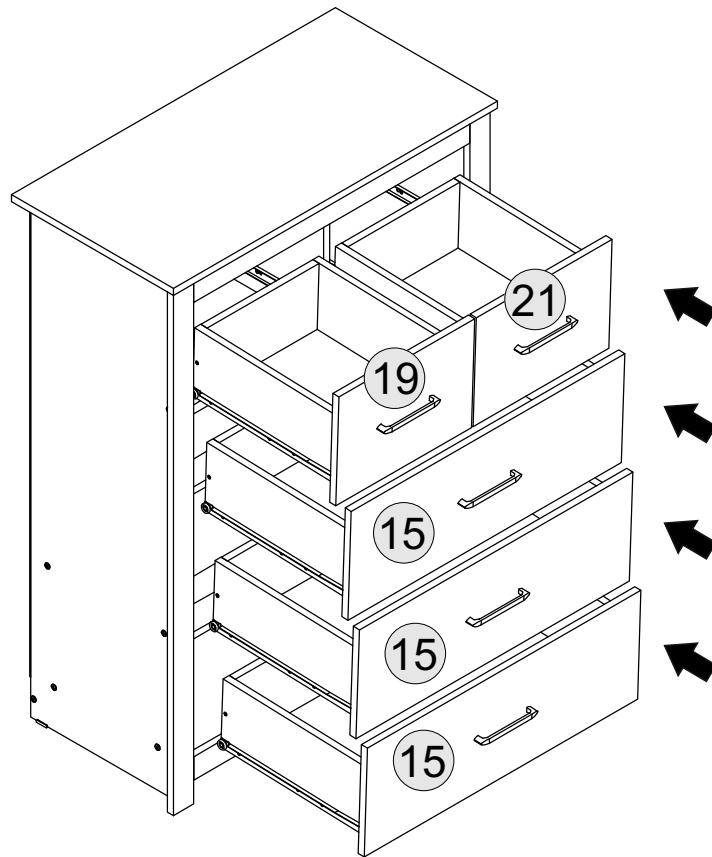

STEP 20

PART REQUIRED

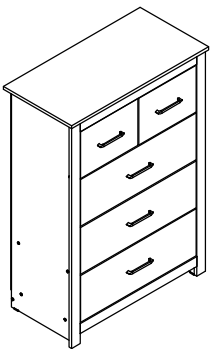

HARDWARE REQUIRED

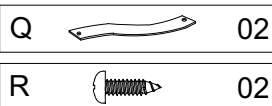

TOOLS REQUIRED

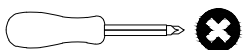

WARNING

Serious or fatal injuries can occur from furniture tipping over. To prevent the furniture from tipping over we recommend that it is permanently fixed to the wall.

Wall fixings are not supplied with this product as different wall materials require different types of fixing devices. Please make sure you use fixings suitable for the walls in your home.

