

55522

# CORONA 4 DRAWER CHEST ASSEMBLY INSTRUCTIONS

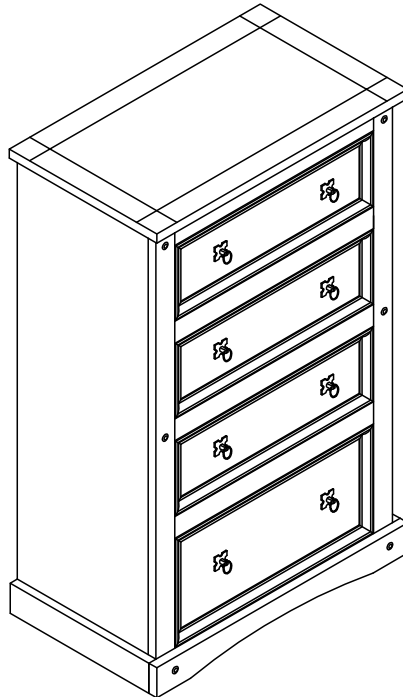

## **IMPORTANT** PLEASE READ BEFORE YOU CONTINUE FURTHER **FOR DOMESTIC USE ONLY** **CARE AND MAINTENANCE**

After unpacking this product please keep the original packaging in case it needs to be returned for any reason.

- Please ensure all fittings and parts are present before commencing with assembly.
- We recommend that you lay a blanket or sheet on the floor to avoid damage to both your floor and the product.
- We strongly recommend that you keep children away from your work area.
- Assemble this product as close to its final position as possible.
- Never drag or push products as this could cause damage to the joints making it inferior.
- Do not place this product next to a radiator or in direct sunlight.
- Wood is a natural product and may expand if subjected to damp and may shrink or crack if subjected to heat. Therefore it is recommended that room temperature is maintained, with no sudden temperature fluctuations.
- Make sure any spillage is wiped off immediately.
- Do not place hot or chilled items directly on to the surface, use a place mat or marking will occur.
- For general cleaning use a duster, and do not use detergents of any kind. However, the surface will need to be retreated from time to time. This can be done by using block wax (unperfumed) and rubbing it over the whole item.
- From time to time it may be necessary to tighten fittings, regular inspections should be carried out.

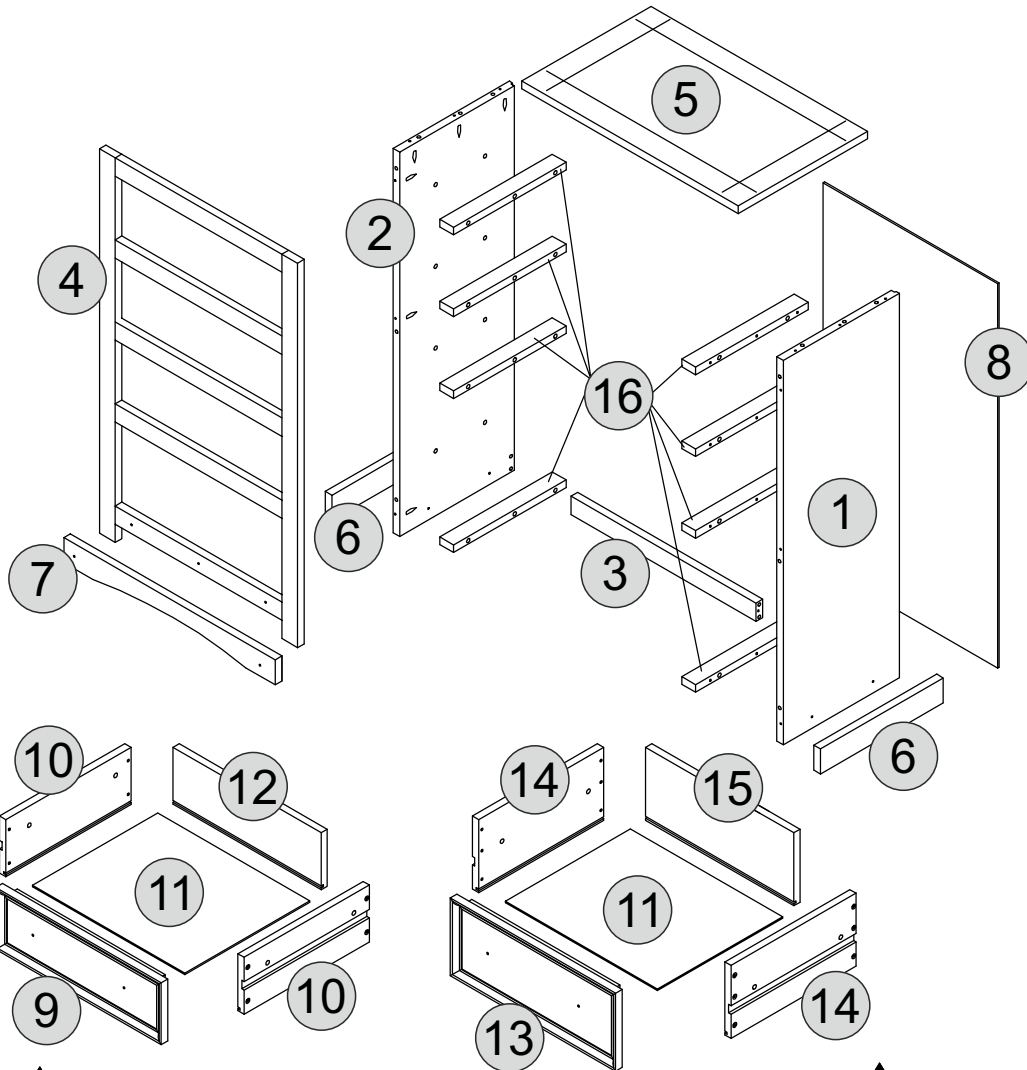

\* Use of power tools to assemble this product will invalidate any claim and damage this product making it unsafe !!!  
 \* Please assemble on a clean soft surface to avoid damage.







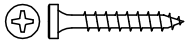

\* Please check contents and read the instructions before commencing assembly.  
 \* Assemble this product following the enclosed instructions carefully.  
 \* Please take care to avoid damaging panels during assembly.

**Please Note:**  
 The below Highlighted parts have all been stamped with the part number to help identify them during assembly.

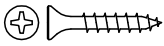
**PARTS LIST**

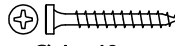
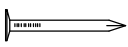
Part Number	Part Code	Part Description	Quantity	Carton
1	S100-102-025-PJ1-01	Right Side Panel	1	1/2
2	S100-102-025-PJ1-02	Left Side Panel	1	1/2
3	S100-102-025-PJ1-03	Back Crossbeam	1	1/2
4	S100-102-025-PJ1-04	Front Frame	1	1/2
5	S100-102-025-PJ1-05	Top	1	2/2
6	S100-102-025-PJ1-06	Side Plinth	2	2/2
7	S100-102-025-PJ1-07	Front Plinth	1	2/2
8	S100-102-025-PJ1-08	Back Panel	1	1/2
9	S100-102-025-PJ1-09	Small Drawer Front	3	2/2
10	S100-102-025-PJ1-10	Small Drawer Side	6	1/2
11	S100-102-025-PJ1-11	Drawer Bottom	4	1/2
12	S100-102-025-PJ1-12	Small Drawer Back	3	1/2
13	S100-102-025-PJ1-13	Large Drawer Front	1	2/2
14	S100-102-025-PJ1-14	Large Drawer Side	2	1/2
15	S100-102-025-PJ1-15	Large Drawer Back	1	1/2
16	S100-102-025-PJ1-16	Drawer Runner	8	1/2

### FITTINGS

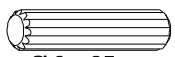
<b>A</b> <small>(+2)</small>	 <b>Ø 3,5 x 35mm</b>	<b>21</b>	<b>F</b>		<b>08</b>
<b>B</b> <small>(+2)</small>	 <b>Ø 3 x 30mm</b>	<b>36</b>	<b>G</b> <small>(+1)</small>		<b>06</b>
<b>C</b>	 <b>3/16" x 3/4"</b>	<b>08</b>	<b>H</b> <small>(+2)</small>	 <b>Ø 4 x 40mm</b>	<b>24</b>
<b>D</b> <small>(+2)</small>	 <b>10 x 10</b>	<b>30</b>	<b>I</b>	 2x  1x  1x	<b>01</b>
<b>E</b> <small>(+2)</small>	 <b>Ø 8 x 25mm</b>	<b>40</b>			

### TOOLS REQUIRED

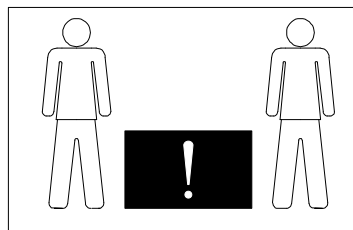
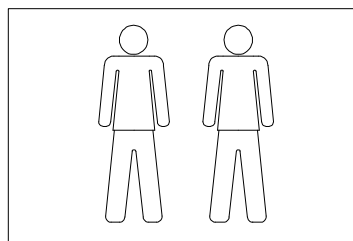
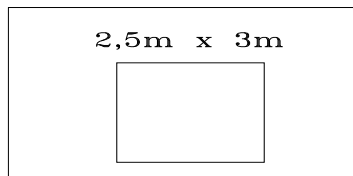
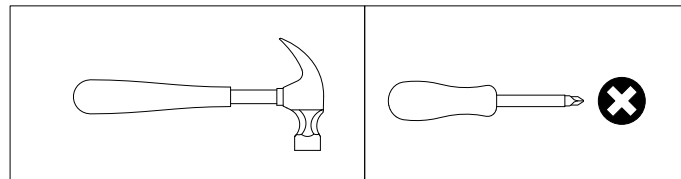

# STEP 1

**PARTS REQUIRED**

2 - LEFT SIDE PANEL x1

**HARDWARE REQUIRED**

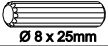
E  06  
Ø 8 x 25mm

**TOOLS REQUIRED**

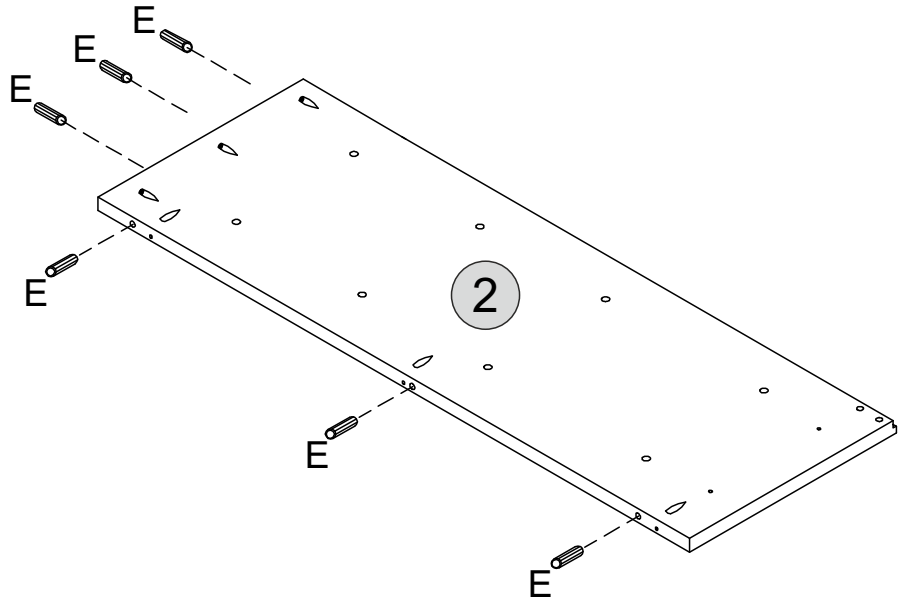

Please assemble on a clean soft surface to avoid damage.

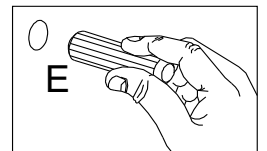

# STEP 2

**PARTS REQUIRED**

1 - RIGHT SIDE PANEL x1

**HARDWARE REQUIRED**

E  06  
Ø 8 x 25mm

**TOOLS REQUIRED**

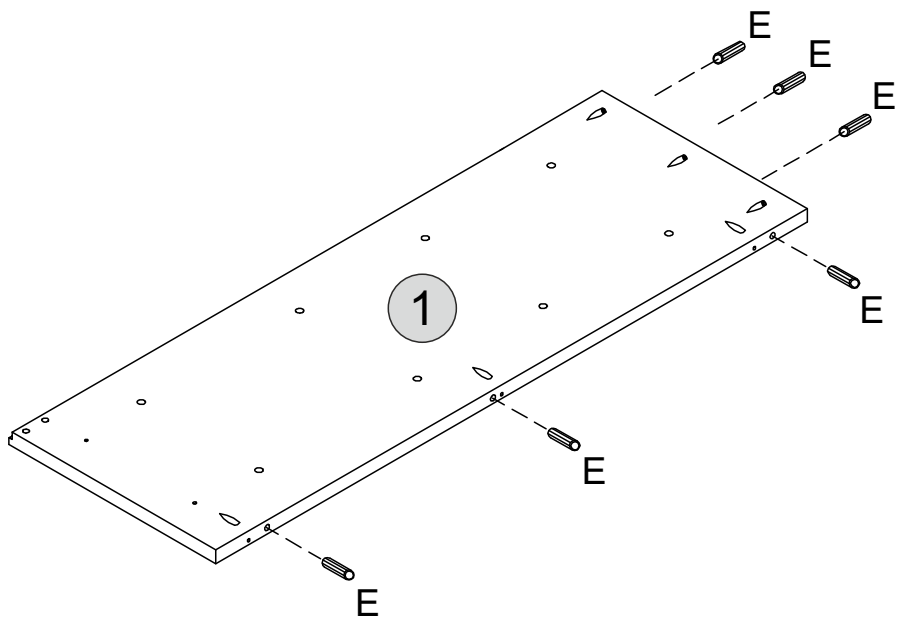

Please assemble on a clean soft surface to avoid damage.

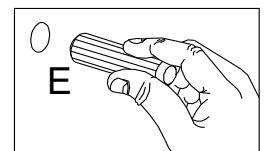

# STEP 3

## PARTS REQUIRED

- 3 - BACK CROSSBEAM x1
- 16 - DRAWER RUNNER x8

## HARDWARE REQUIRED



## TOOLS REQUIRED

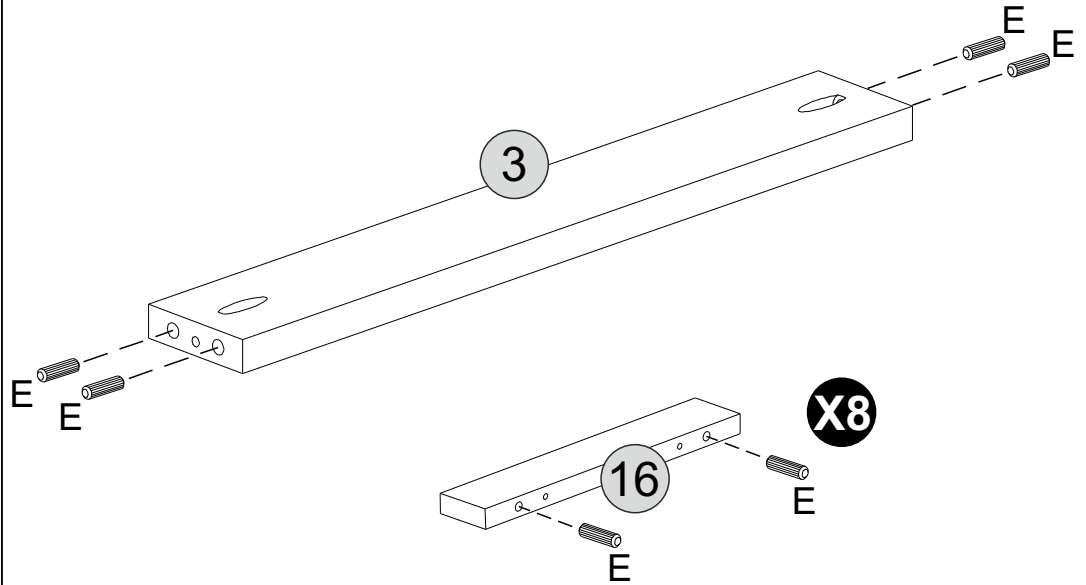

**!**  
Please assemble on a clean soft surface to avoid damage.

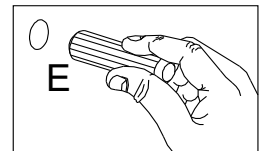

# STEP 4

## PARTS REQUIRED

- 1 - RIGHT SIDE PANEL x1
- 16 - DRAWER RUNNER x3

## HARDWARE REQUIRED

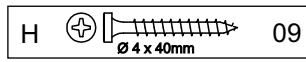

## TOOLS REQUIRED

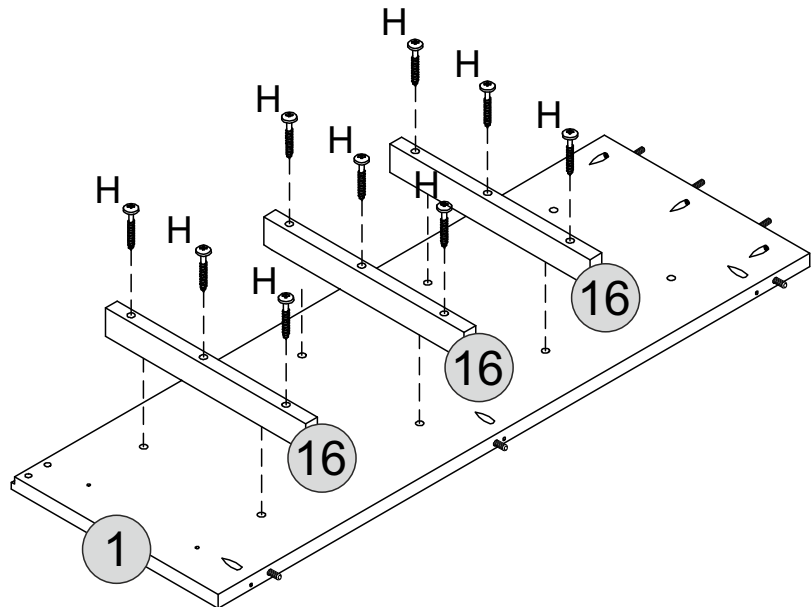
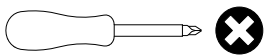

**!**  
Please assemble on a clean soft surface to avoid damage.

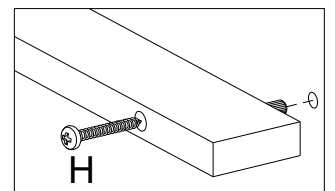

# STEP 5

## PARTS REQUIRED

- 2 - LEFT SIDE PANEL x1
- 16 - DRAWER RUNNER x3

## HARDWARE REQUIRED

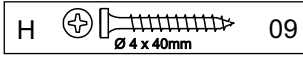

## TOOLS REQUIRED

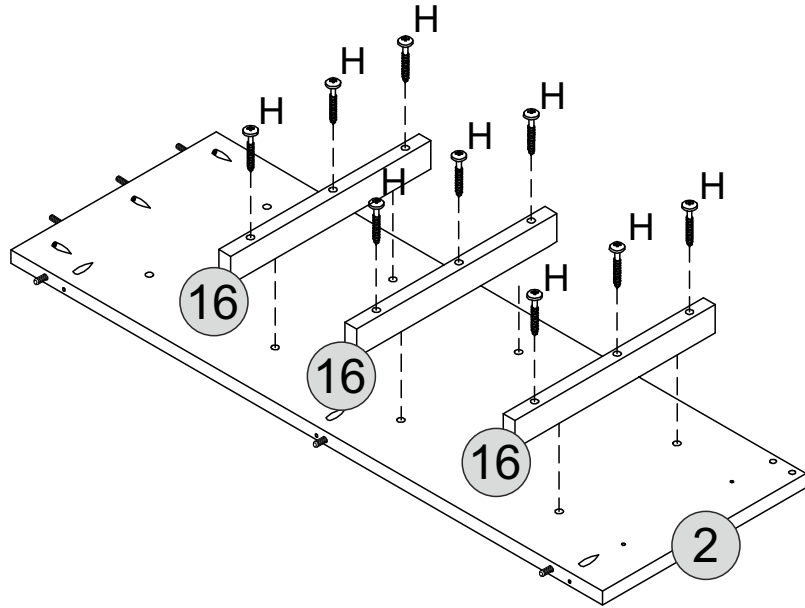
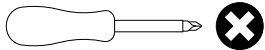

**!**  
Please assemble on a clean soft surface to avoid damage.

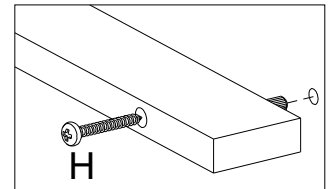

# STEP 6

## PARTS REQUIRED

- 1 - RIGHT SIDE PANEL x1
- 2 - LEFT SIDE PANEL x1
- 3 - BACK CROSSBEAM x1

## HARDWARE REQUIRED

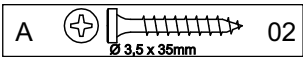

## TOOLS REQUIRED

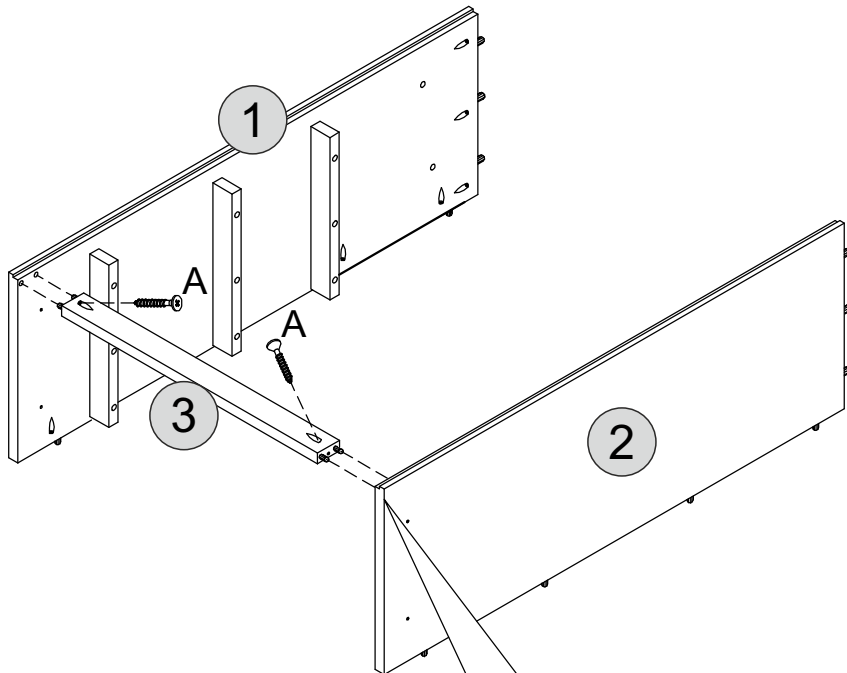
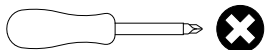

**!**  
Please assemble on a clean soft surface to avoid damage.

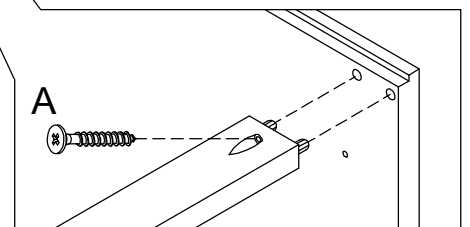

# STEP 7

## PARTS REQUIRED

4 - FRONT FRAME x1

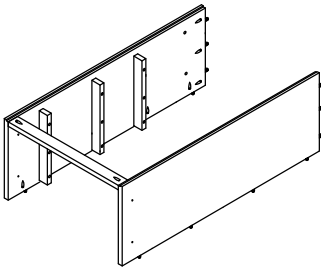

## HARDWARE REQUIRED

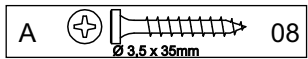

## TOOLS REQUIRED

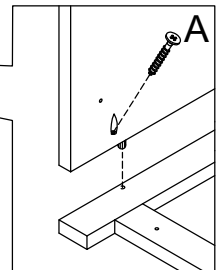
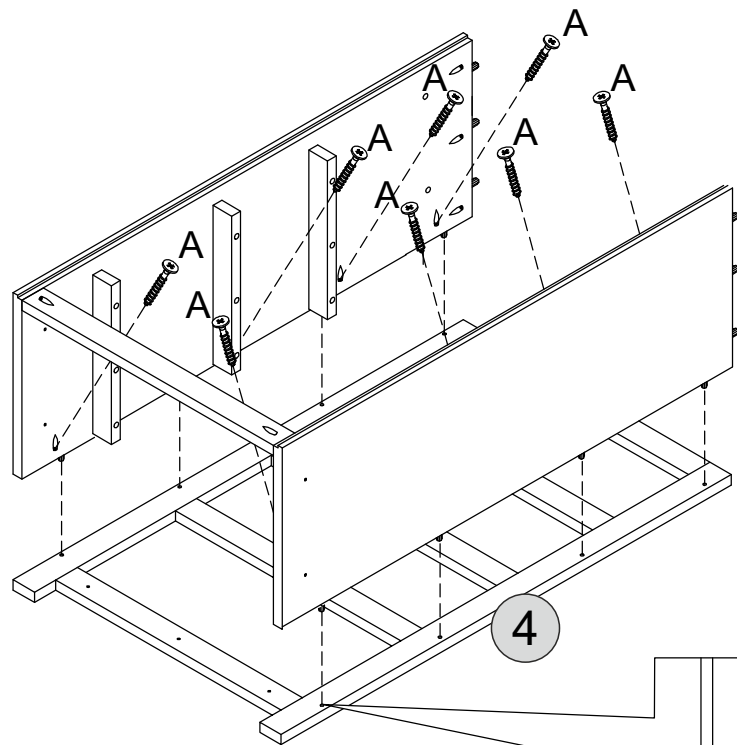
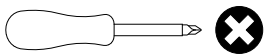

**!**  
Please assemble on a clean soft surface to avoid damage.

# STEP 8

## PARTS REQUIRED

5 - TOP x1

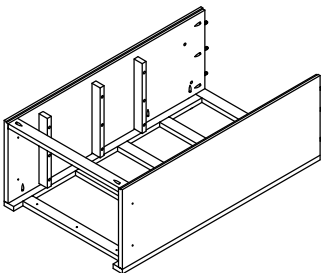

## HARDWARE REQUIRED

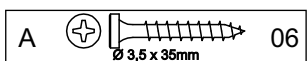

## TOOLS REQUIRED

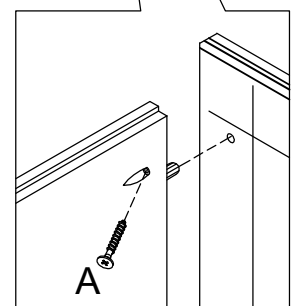
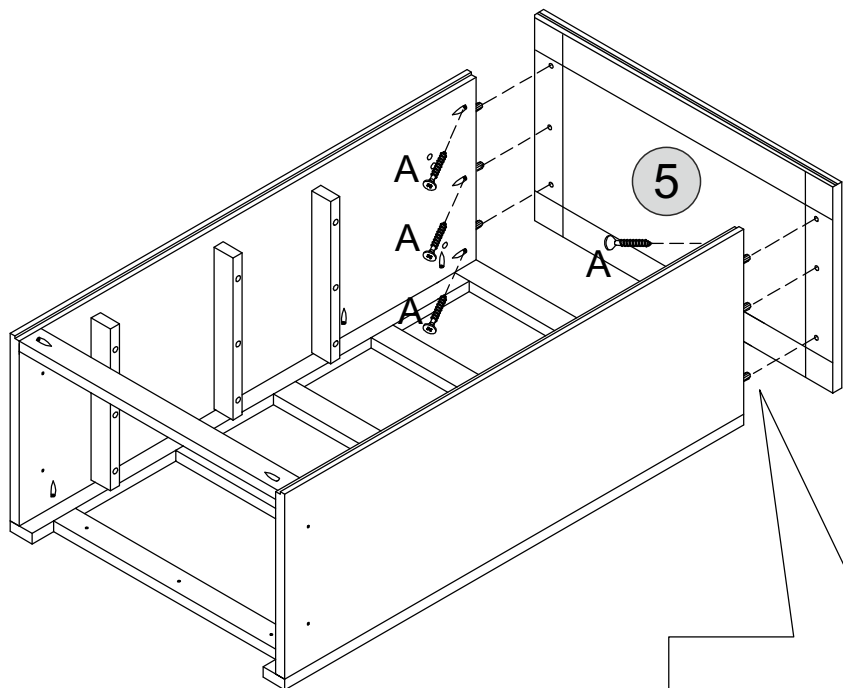
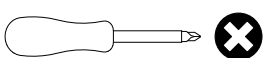

**!**  
Please assemble on a clean soft surface to avoid damage.



# STEP 9

## PARTS REQUIRED

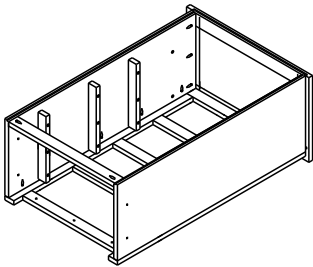
- 6 - SIDE PLINTH x2
- 16 - DRAWER RUNNER x2



## HARDWARE REQUIRED

- A  04  
Ø 3,5 x 35mm
- H  06  
Ø 4 x 40mm

## TOOLS REQUIRED

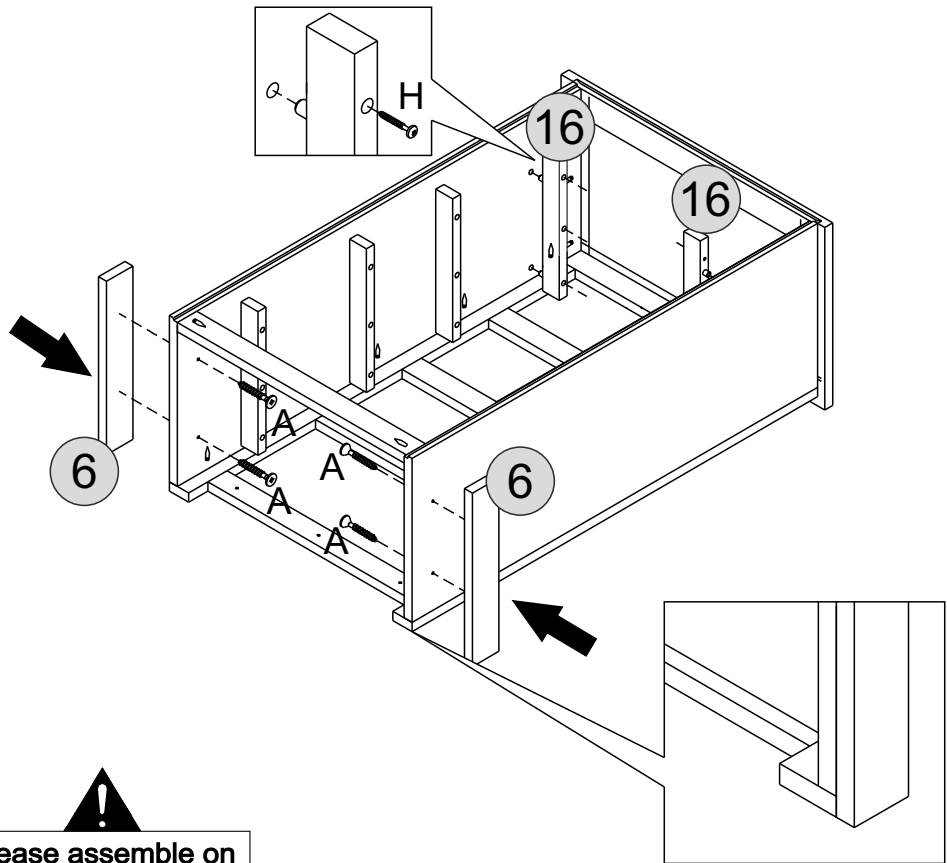
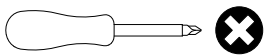

**Please assemble on a clean soft surface to avoid damage.**

# STEP 10

## PARTS REQUIRED

- 7 - FRONT PLINTH x3

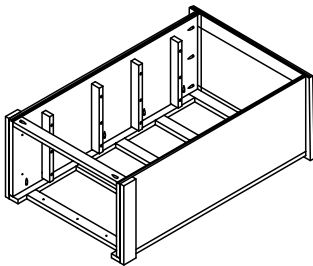

## HARDWARE REQUIRED

- A  03  
Ø 3,5 x 35mm

## TOOLS REQUIRED

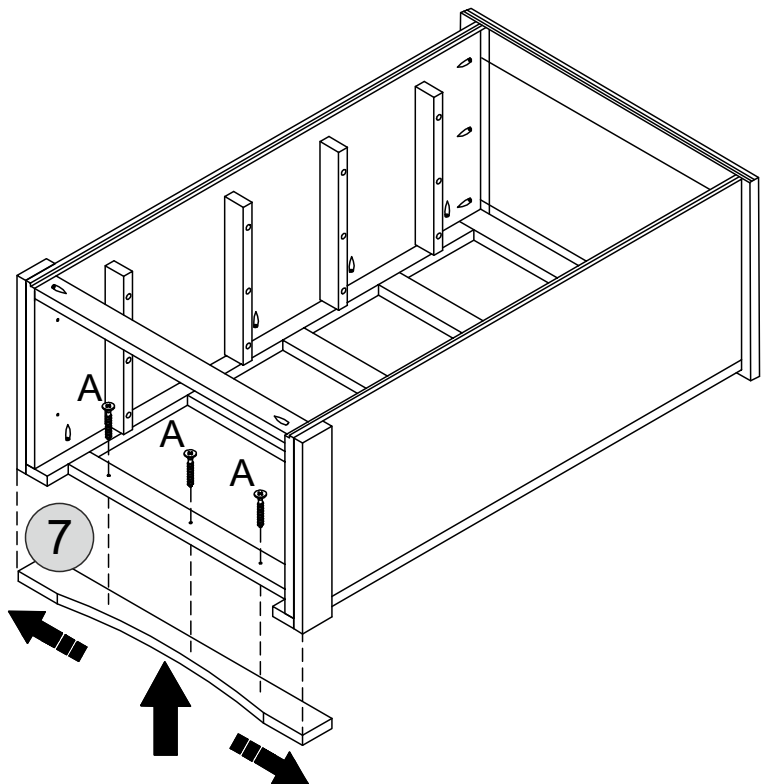
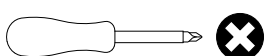

**Please assemble on a clean soft surface to avoid damage.**



# STEP 11

## PARTS REQUIRED

8 - BACK PANEL x1

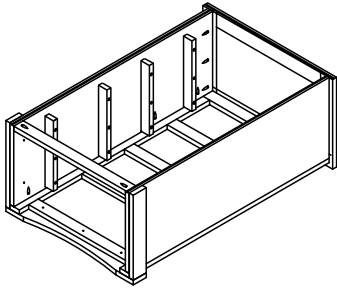

## HARDWARE REQUIRED

D  30

## TOOLS REQUIRED

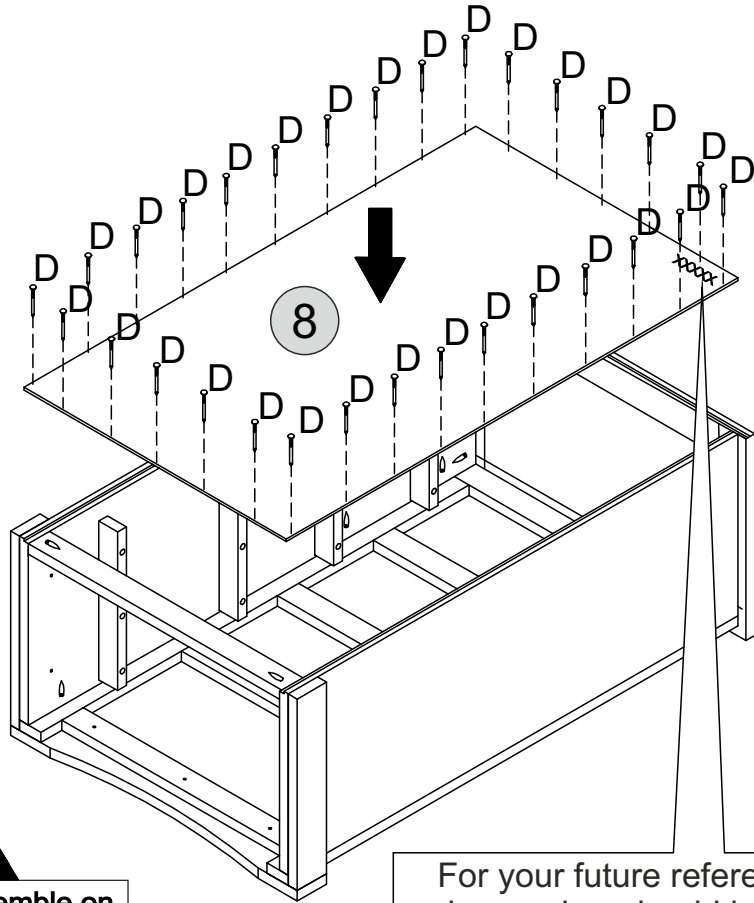
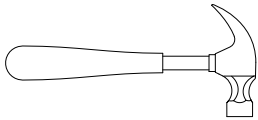

**!**  
Please assemble on a clean soft surface to avoid damage.

For your future reference order number should be here

# STEP 12

## PARTS REQUIRED

9 - SMALL DRAWER FRONT x3

10 - SMALL DRAWER SIDE x6

## HARDWARE REQUIRED

B  12  
Ø 3 x 30mm

C  06  
3/16" x 3/4"

F  06

## TOOLS REQUIRED

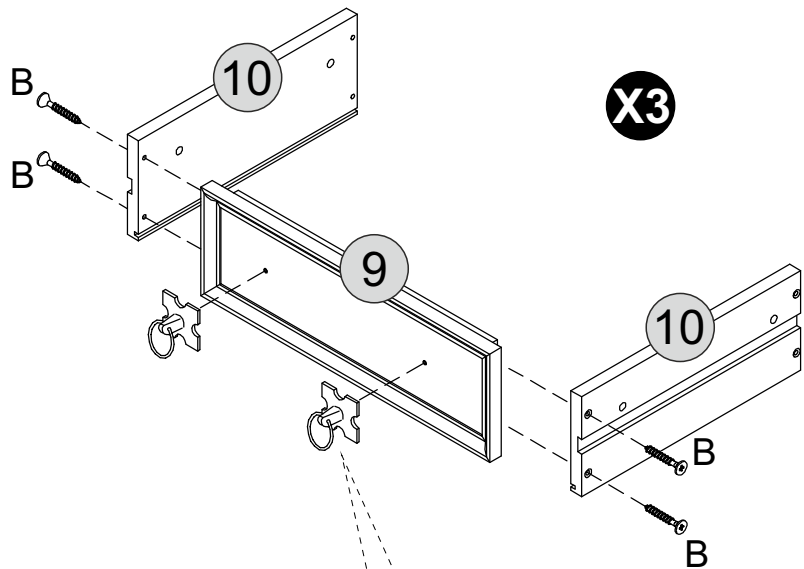
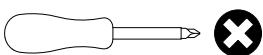

**!**  
Please assemble on a clean soft surface to avoid damage.

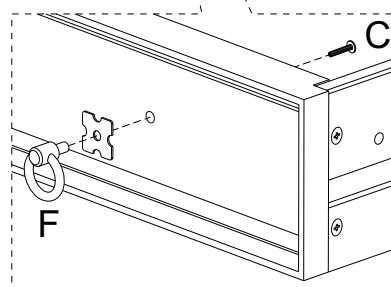

# STEP 13

## PARTS REQUIRED

11 - DRAWER BOTTOM x3

12 - SMALL DRAWER BACK x3

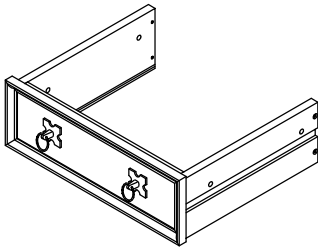

**X3**

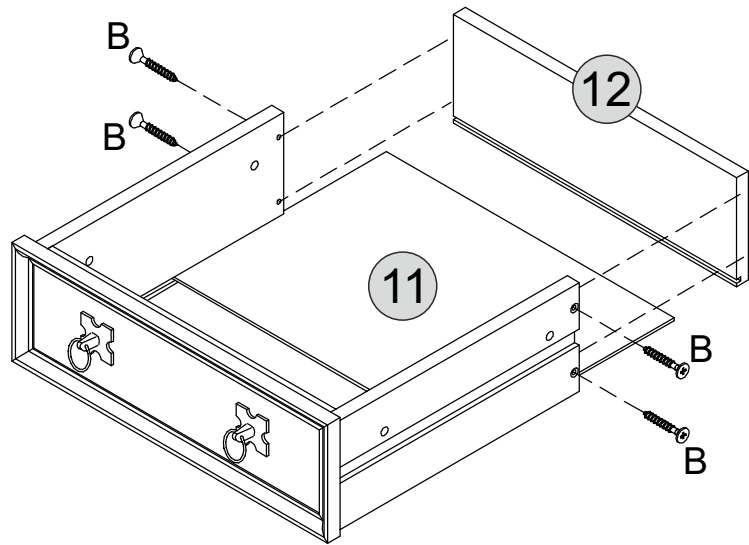

## HARDWARE REQUIRED

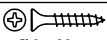
B  12  
Ø 3 x 30mm

## TOOLS REQUIRED

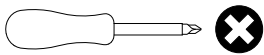

# STEP 14

## PARTS REQUIRED

13 - LARGE DRAWER FRONT x1

14 - LARGE DRAWER SIDE x2

## HARDWARE REQUIRED

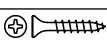
B  06  
Ø 3 x 30mm

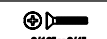
C  02  
3/16" x 3/4"

F  02

## TOOLS REQUIRED

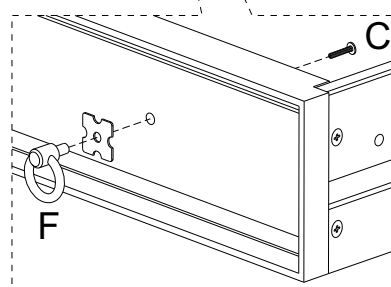
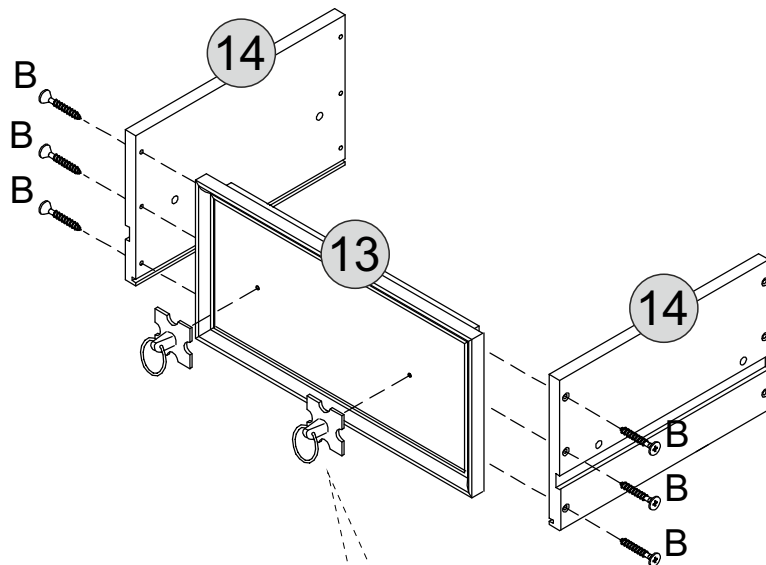
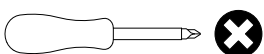

# STEP 15

## PARTS REQUIRED

11 - DRAWER BOTTOM x1

15 - SMALL DRAWER BACK x1

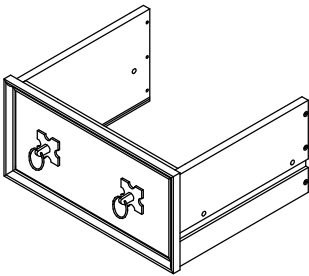

## HARDWARE REQUIRED

B  06  
Ø 3 x 30mm

## TOOLS REQUIRED

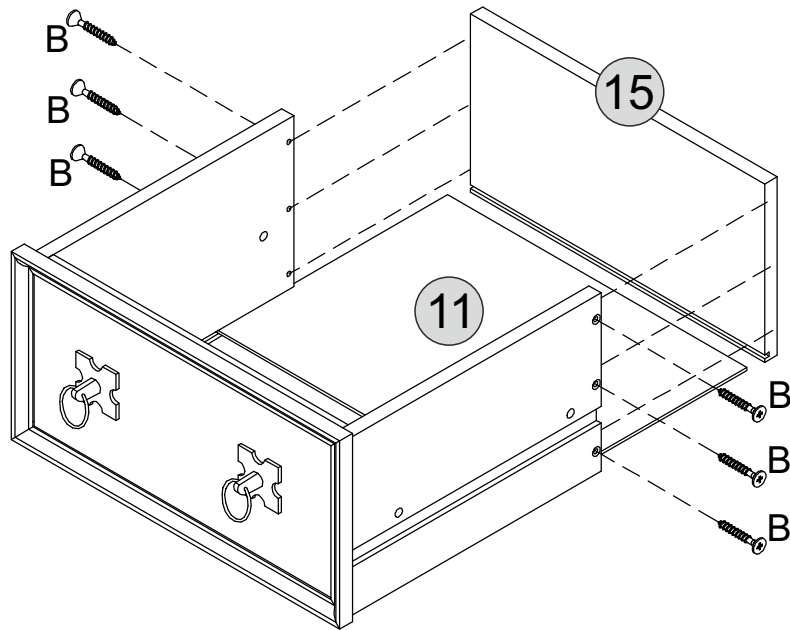
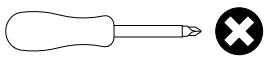

# STEP 16

## PARTS REQUIRED

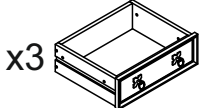
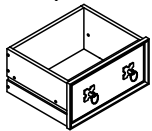
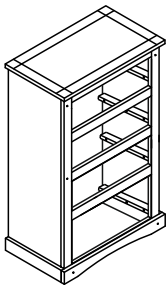

## HARDWARE REQUIRED

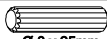
E  08  
Ø 8 x 25mm

G  06

## TOOLS REQUIRED

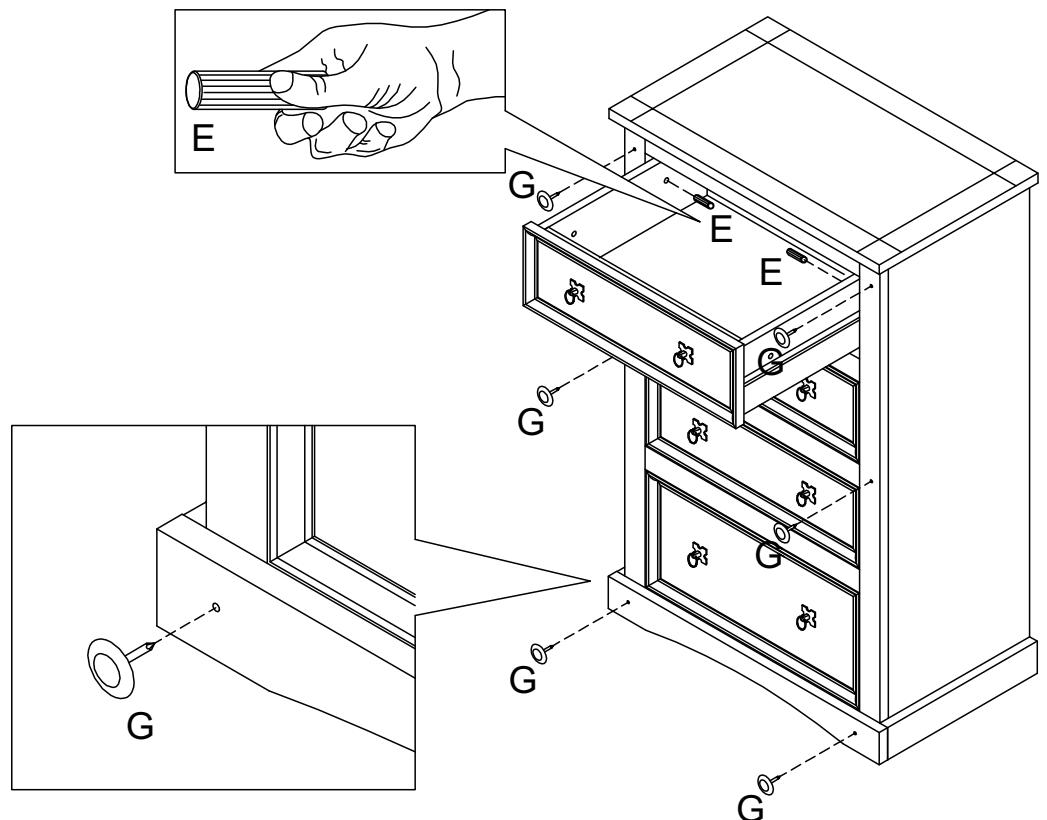
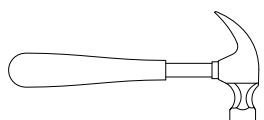

# STEP 17

**PARTS REQUIRED**

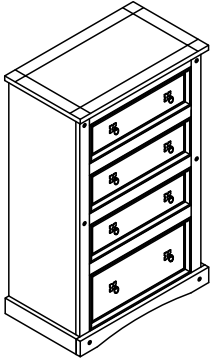

**HARDWARE REQUIRED**

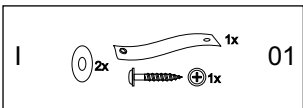

**TOOLS REQUIRED**

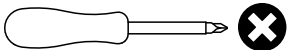

## WARNING

**Serious or fatal injuries can occur from furniture tipping over. To prevent the furniture from tipping over we recommend that it is permanently fixed to the wall.**

Wall fixings are not supplied with this product as different wall materials require different types of fixing devices. Please make sure you use fixings suitable for the walls in your home.

