

MONACO 4'6" HIGH END BED ASSEMBLY INSTRUCTIONS



FOR DOMESTIC USE ONLY

IMPORTANT

PLEASE READ BEFORE YOU CONTINUE FURTHER

CARE AND MAINTENANCE

After unpacking this product please keep the original packaging in case it needs to be returned for any reason.

- Please ensure all fittings and parts are present before commencing with assembly.
- We recommend that you lay a blanket or sheet on the floor to avoid damage to both your floor and the product.
- We strongly recommend that you keep children away from your work area.
- Assemble this product as close to its final position as possible.
- Never drag or push products as this could cause damage to the joints making it inferior.
- Do not place this product next to a radiator or in direct sunlight.
- Wood is a natural product and may expand if subjected to damp and may shrink or crack if subjected to heat. Therefore it is recommended that room temperature is maintained, with no sudden temperature fluctuations.
- Make sure any spillage is wiped off immediately.
- Do not place hot or chilled items directly on to the surface, use a place mat or marking will occur.
- For general cleaning use a duster, and do not use detergents of any kind. However, the surface will need to be retreated from time to time. This can be done by using block wax (unperfumed) and rubbing it over the whole item.
- From time to time it may be necessary to tighten fittings, regular inspections should be carried out.

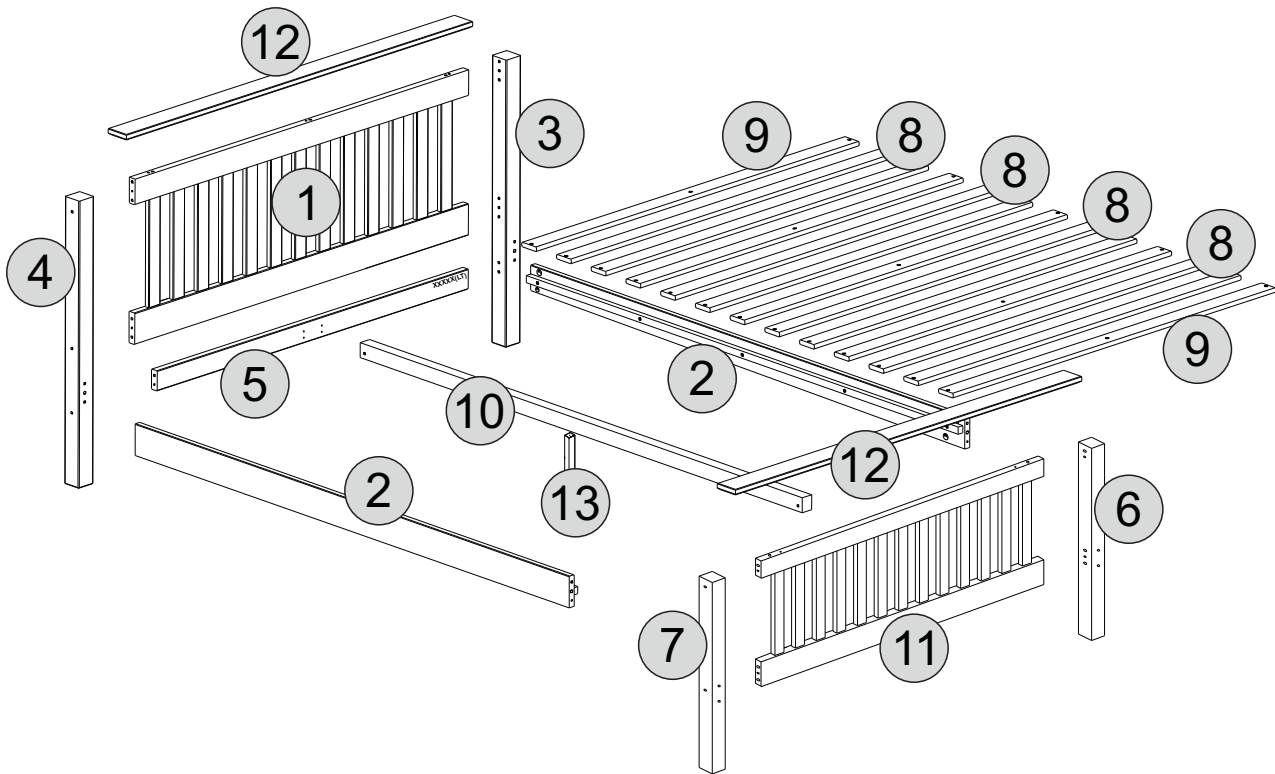







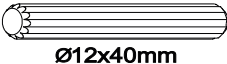

!
 * Use of power tools to assemble this product will invalidate any claim and damage this product making it unsafe !!!
 * Please assemble on a clean soft surface to avoid damage.

!
 * Please check contents and read the instructions before commencing assembly.
 * Assemble this product following the enclosed instructions carefully.
 * Please take care to avoid damaging panels during assembly.

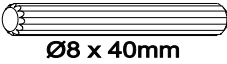
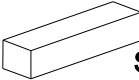
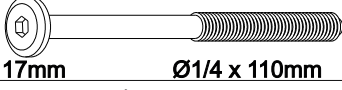
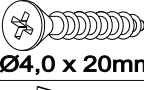
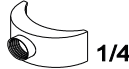
PARTS LIST

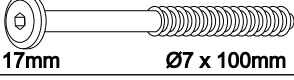
Part Number	Part Code	Part Description	Quantity	Carton
1	S200-204-006-LT1-01	Headboard Panel	1	1/4
2	S200-204-006-LT1-02	Siderails	2	3/4
3	S200-204-006-LT1-03	Right Headboard Post	1	2/4
4	S200-204-006-LT1-04	Left Headboard Post	1	2/4
5	S200-204-006-LT1-05	Headboard Crossbeam	1	1/4
6	S200-204-006-LT1-06	Right Footboard Post	1	2/4
7	S200-204-006-LT1-07	Left Footboard Post	1	2/4
8	S200-204-006-LT1-08	Slats (2 Holes)	8	4/4
9	S200-204-006-LT1-09	Slats (3 Holes)	5	4/4
10	S200-204-006-LT1-10	Centre Support	1	3/4
11	S200-204-006-LT1-11	Footboard Panel	1	1/4
12	S200-204-006-LT1-12	Plinths	2	3/4
13	S200-204-006-LT1-13	Centre Support Leg	1	3/4

FITTINGS

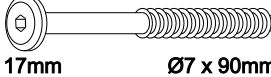
A	 Ø12x40mm	04	H		01
B	 Ø8 x 40mm	24	I	 SPACER 87mm	02
C	 17mm Ø1/4 x 110mm	08	J	 Ø4,0 x 20mm	08
D	 1/4	08	K		02
E	 17mm Ø7 x 100mm	10	L	 13mm Ø1/4 x 60mm	02
F	 Ø4,0 x 35mm	06	M	 1/4	02
G	 Ø3,5 x 30mm	31	N	 17mm Ø7 x 90mm	01

TOOLS REQUIRED

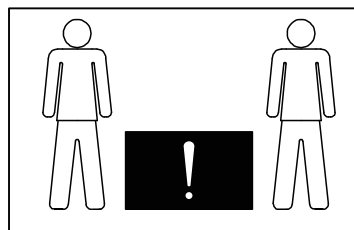
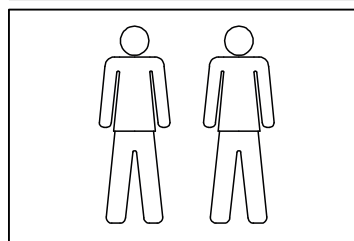
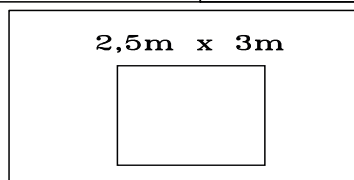
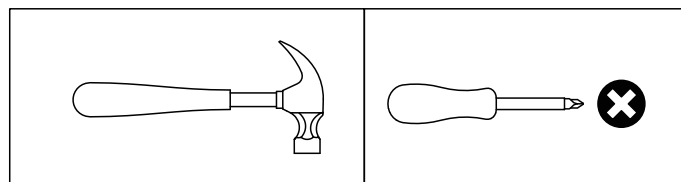

STEP 1

PARTS REQUIRED

2 - SIDERAILS x2

5 - HEADBOARD CROSSBEAM x1

HARDWARE REQUIRED

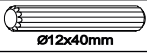
A  04
Ø12x40mm

B  02
Ø8 x 40mm

TOOLS REQUIRED

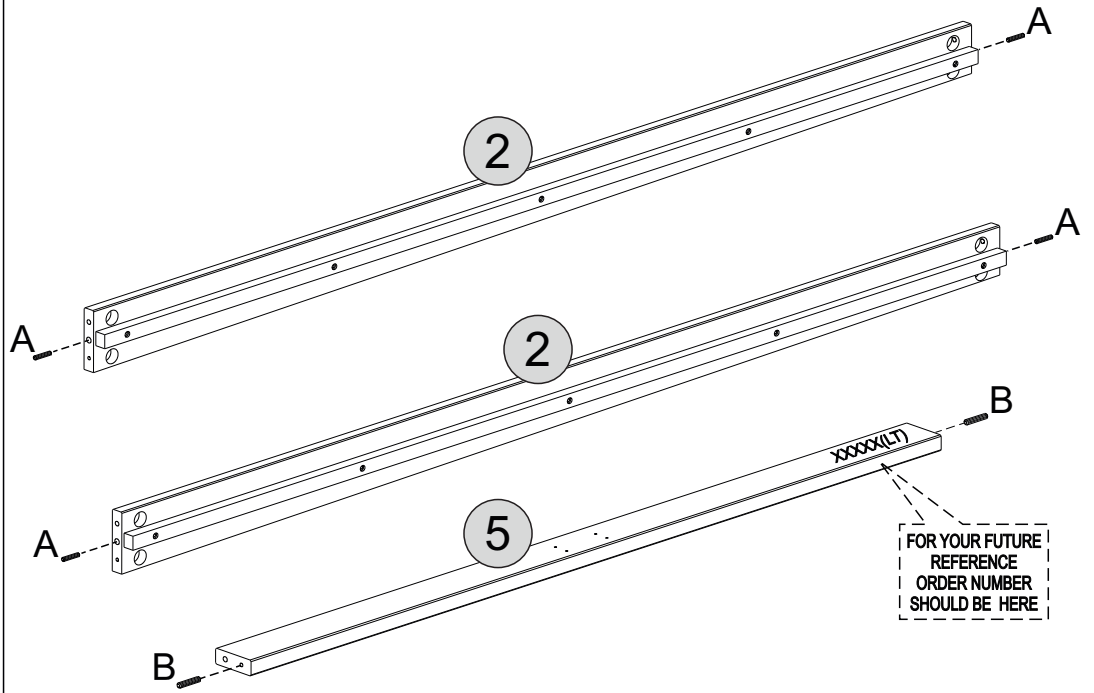

 Please assemble on a clean soft surface to avoid damage.

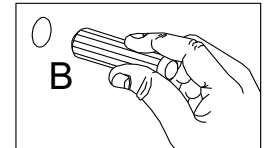
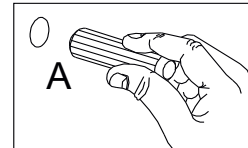

STEP 2

PARTS REQUIRED

1 - HEADBOARD PANEL x1

11 - FOOTBOARD PANEL x1

HARDWARE REQUIRED

B  22
Ø8 x 40mm

TOOLS REQUIRED

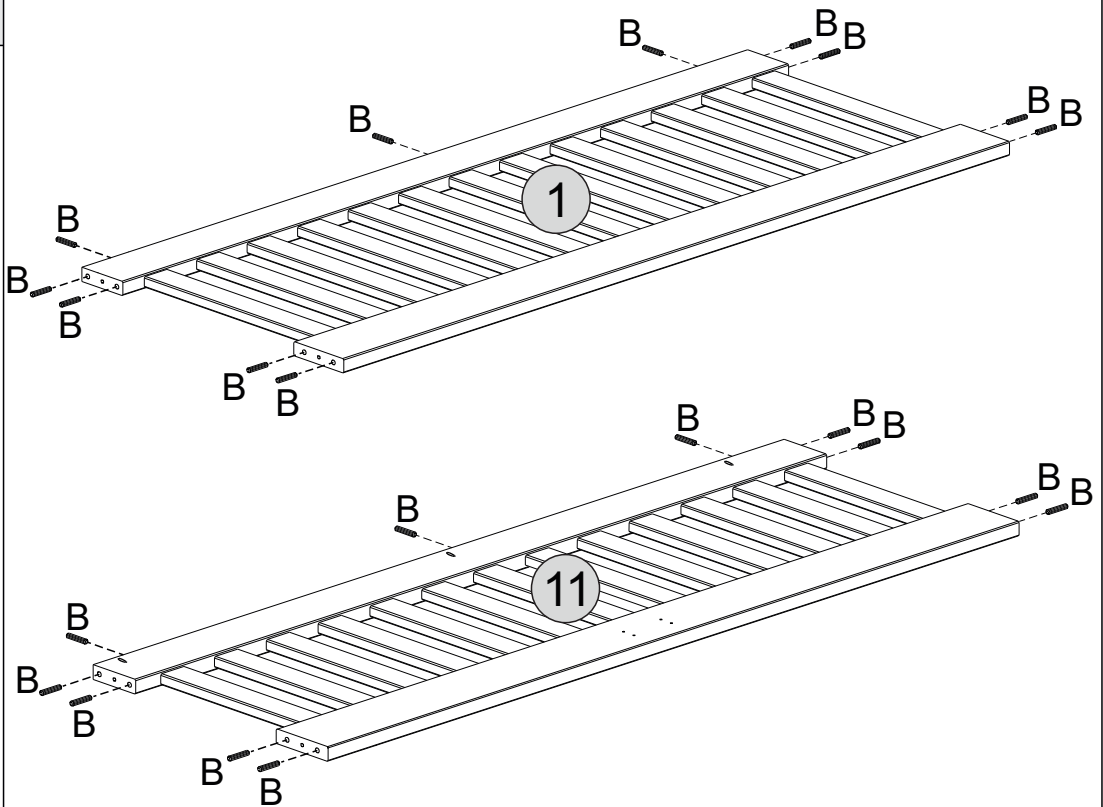

 Please assemble on a clean soft surface to avoid damage.

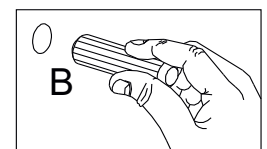

STEP 3

PARTS REQUIRED

- 1 - HEADBOARD PANEL x1
- 3 - RIGHT HEADBOARD POST x1
- 4 - LEFT HEADBOARD POST x1
- 5 - HEADBOARD CROSSBEAM x1

HARDWARE REQUIRED

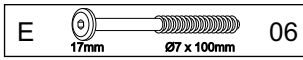

TOOLS REQUIRED

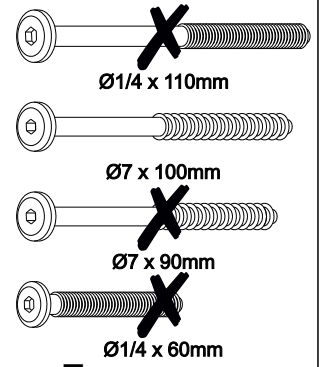
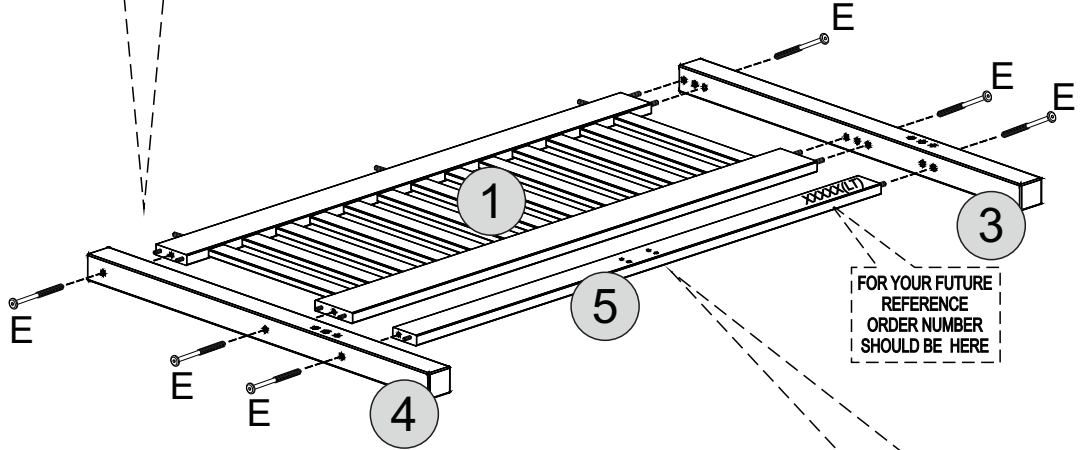
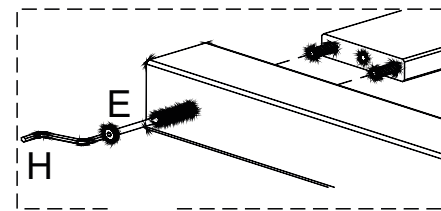
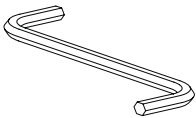

!
Please assemble on a clean soft surface to avoid damage.

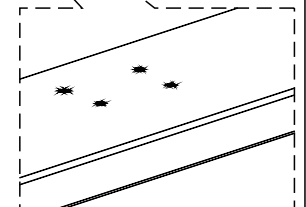

STEP 4

PARTS REQUIRED

- 6 - RIGHT FOOTBOARD POST x1
- 7 - LEFT FOOTBOARD POST x1
- 11 - FOOTBOARD PANEL x1

HARDWARE REQUIRED

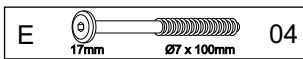

TOOLS REQUIRED

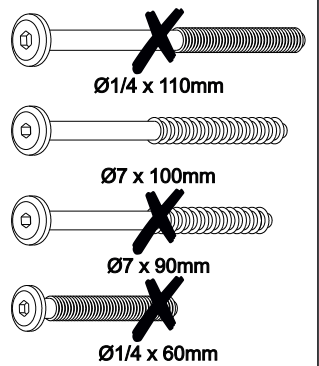
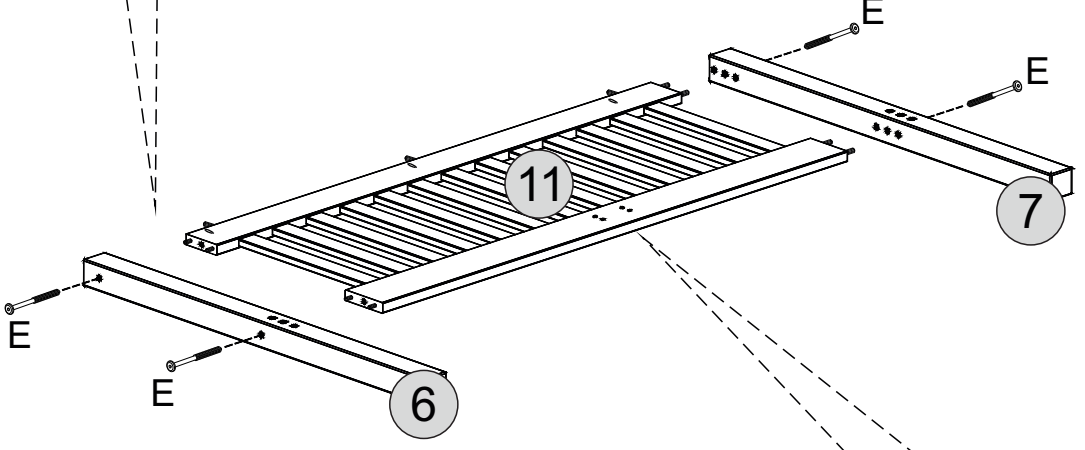
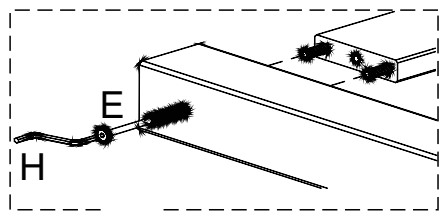
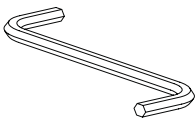

!
Please assemble on a clean soft surface to avoid damage.

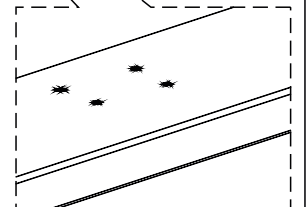

STEP 5

PARTS REQUIRED

2 - SIDERAILS x2

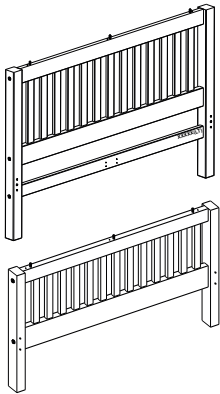

HARDWARE REQUIRED

C  17mm $\varnothing 1/4 \times 110\text{mm}$ 08

D  1/4 08

TOOLS REQUIRED

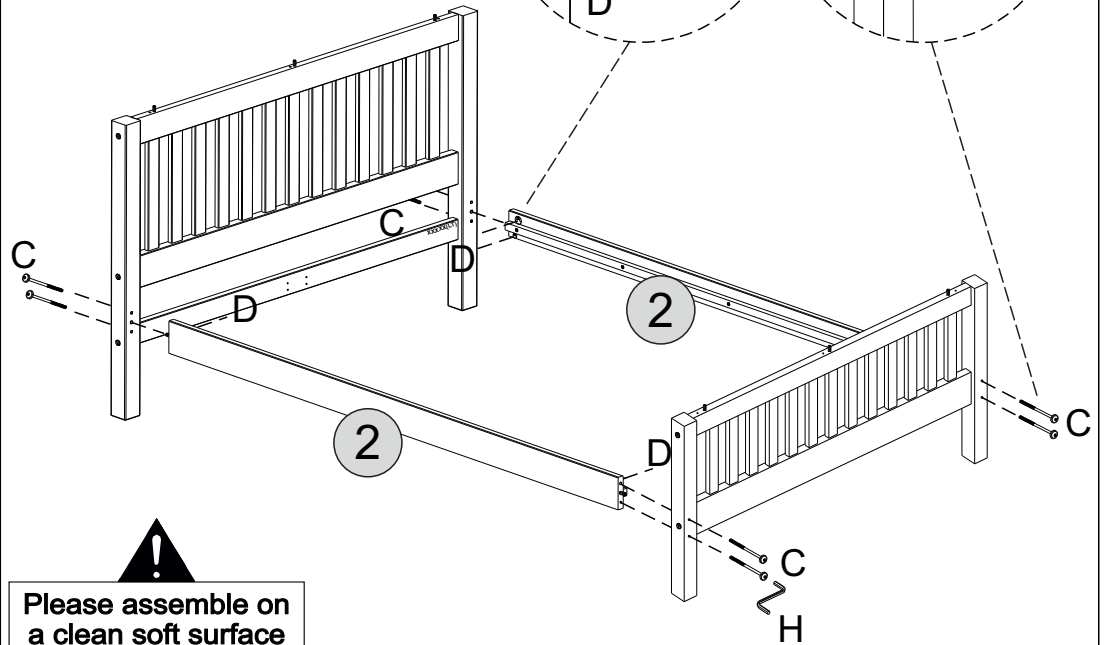
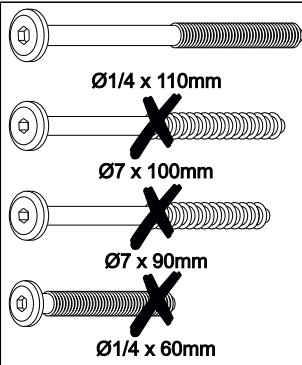
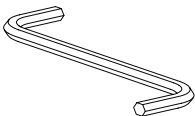

!
Please assemble on a clean soft surface to avoid damage.

STEP 6

PARTS REQUIRED

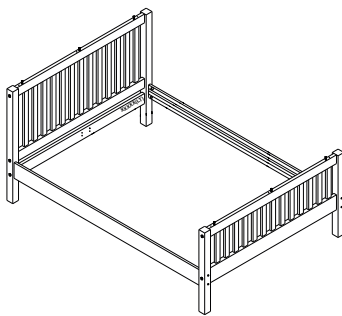

HARDWARE REQUIRED

J  $\varnothing 4,0 \times 20\text{mm}$ 08

K  02

TOOLS REQUIRED

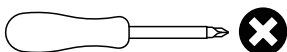

!
When fixing the support (K) carefully line up the screw holes with those pre-drilled on the Headboard and footboard, this will ensure the best assembly

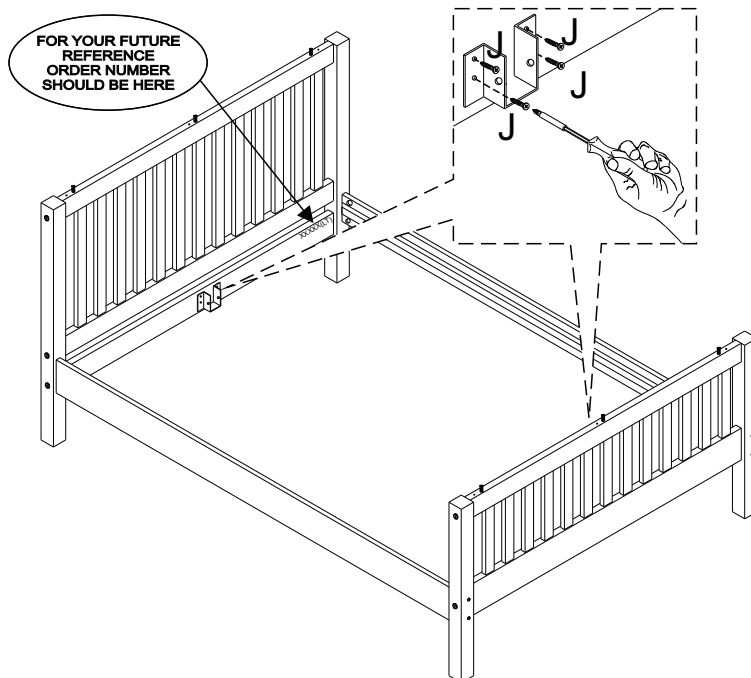

!
Please assemble on a clean soft surface to avoid damage.

STEP 7

PARTS REQUIRED

10 - CENTRE SUPPORT x1

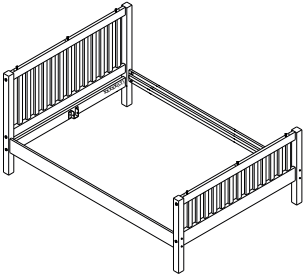

HARDWARE REQUIRED

L  02
13mm Ø1/4 x 60mm

M  1/4 02

TOOLS REQUIRED

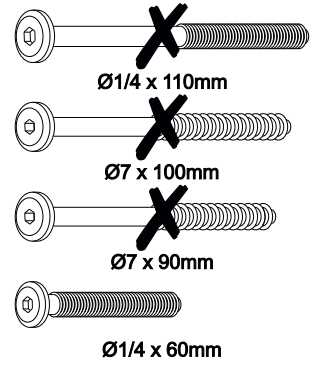
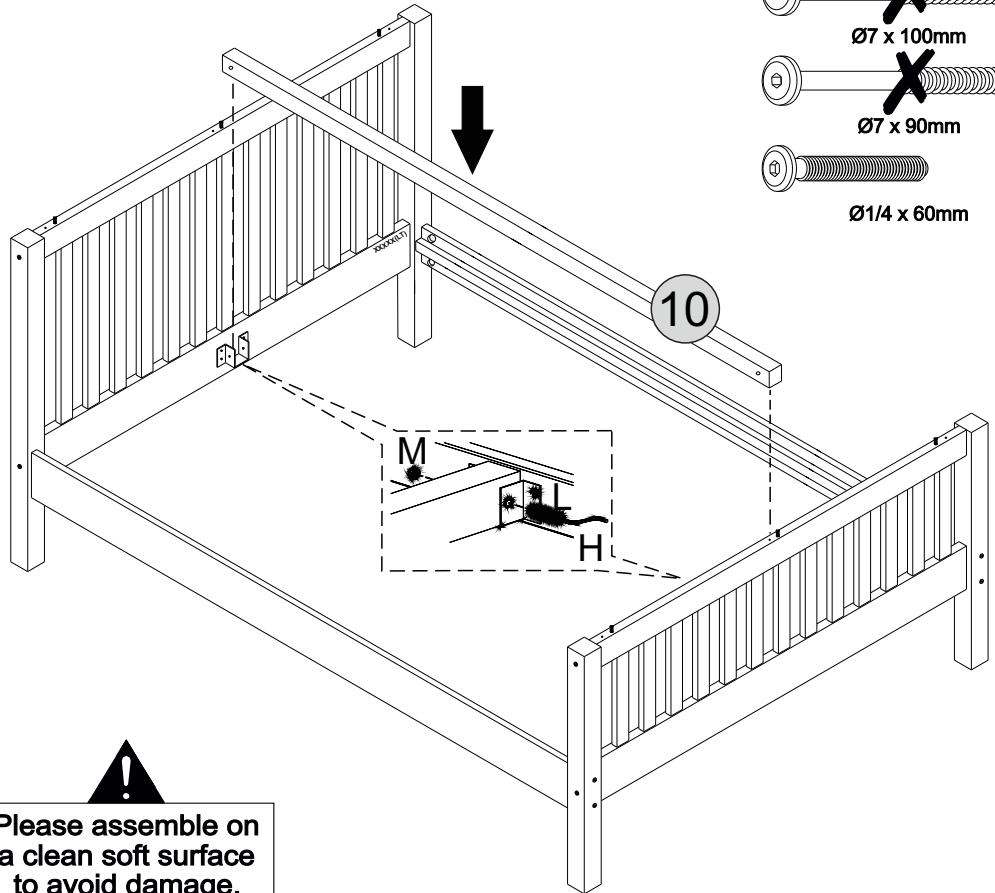
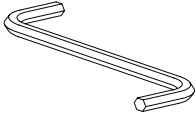

 Please assemble on a clean soft surface to avoid damage.

STEP 8

PARTS REQUIRED

12 - PLINTHS x1

13 - CENTRE SUPPORT LEG x1

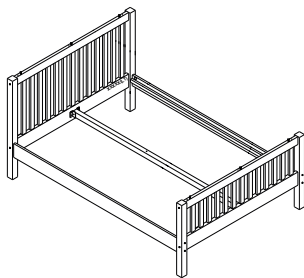

HARDWARE REQUIRED

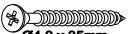
F  06
Ø4,0 x 35mm

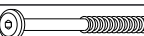
N  01
17mm Ø7 x 90mm

TOOLS REQUIRED

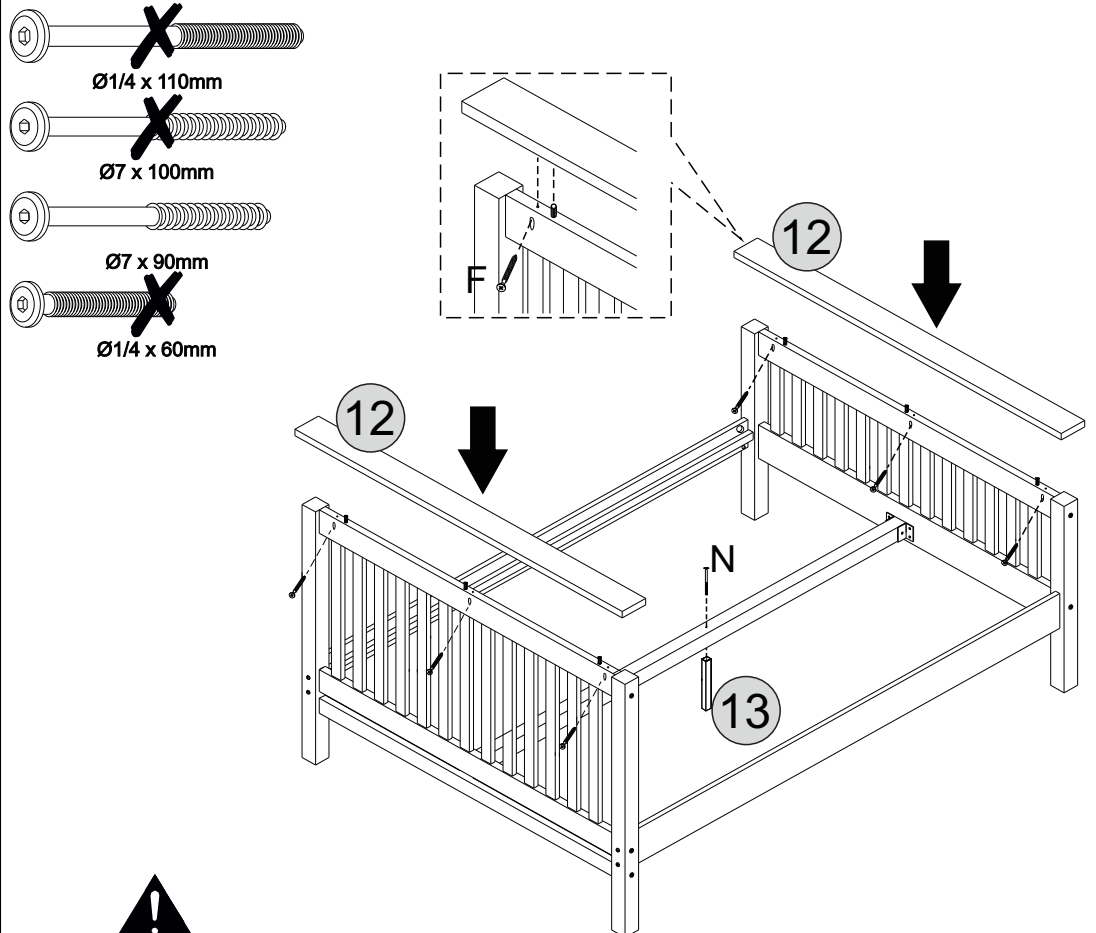
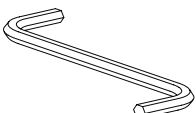
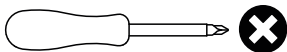

 Please assemble on a clean soft surface to avoid damage.



STEP 9

PARTS REQUIRED

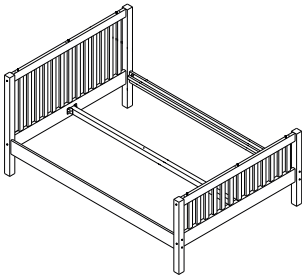
- 8 - SLATS (2 HOLES) x8
- 9 - SLATS (3 HOLES) x5



HARDWARE REQUIRED

- G  31
Ø3,5x 30mm
- I  02

TOOLS REQUIRED

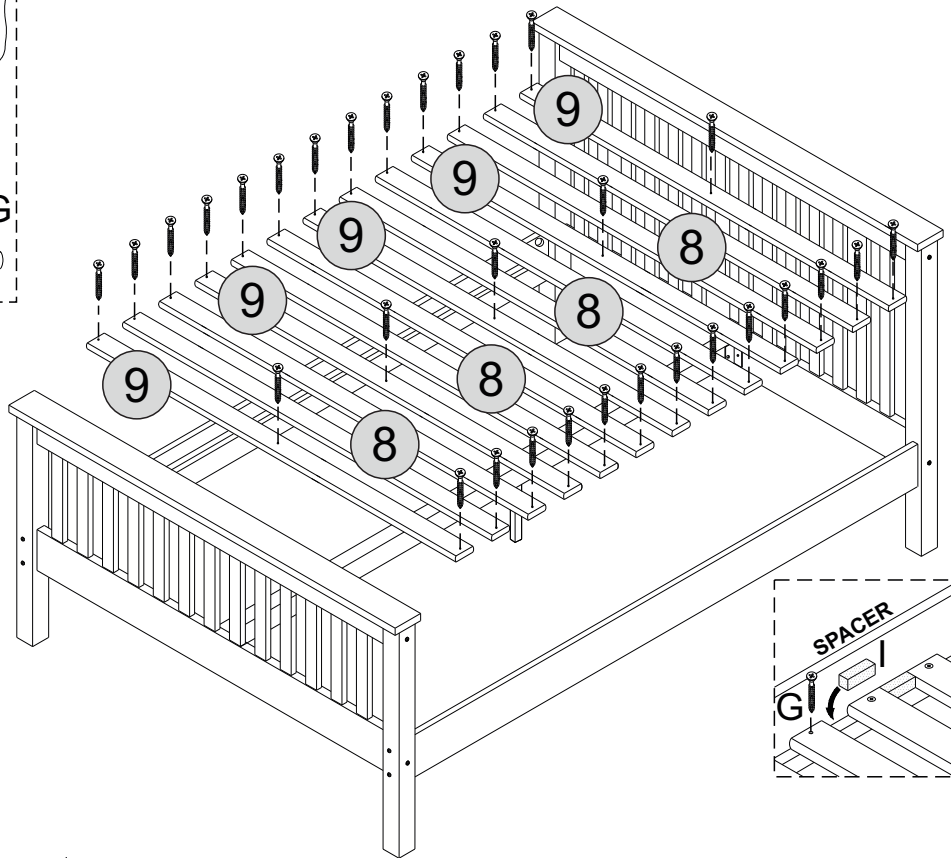
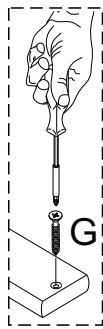
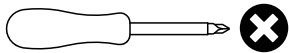

Please assemble on a clean soft surface to avoid damage.

Please fix the first slats adjacent to the headboard and footboard and work towards the middle of the bed using the spacer (I) as shown to ensure the correct spacing. Fix all the slats to one siderail first then push the second siderail tight against the slats and fix.

STEP 10

PARTS REQUIRED

HARDWARE REQUIRED

TOOLS REQUIRED



Please assemble on a clean soft surface to avoid damage.