

# NEVADA 2 DOOR 1 DRAWER WARDROBE BLACK WOOD GRAIN ASSEMBLY INSTRUCTIONS

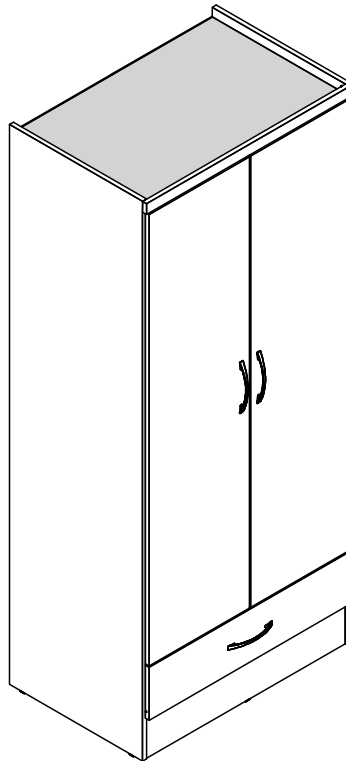

## **IMPORTANT FOR DOMESTIC USE ONLY**

**PLEASE READ BEFORE YOU CONTINUE FURTHER**

# **CARE AND MAINTENANCE**

- After unpacking this product please keep the original packaging in case it needs to be returned for any reason.
- Please ensure all fittings and parts are present before commencing with assembly.
  - Never drag or push products as this could cause damage to the joints making it inferior.
  - We strongly recommend that you keep children away from your work area.
  - We recommend that you lay a blanket or sheet on the floor to avoid damage to both your floor and the product.
  - Assemble this product as close to its final position as possible.
  - Do not place this product next to a radiator or in direct sunlight.
  - Do not drag or push items across your high gloss furniture as this may cause the surface to scratch
  - Wood is a natural product and may expand if subjected to damp and may shrink or crack if subjected to heat. Therefore it is recommended that room temperature is maintained, with no sudden temperature fluctuations.
  - Make sure any spillage is wiped off immediately.
  - Do not place hot or chilled items directly on to the surface, use a place mat or marking will occur.
  - For general cleaning use a soft cotton or micro fibre cloth, and do not use detergents of any kind.
  - From time to time it may be necessary to tighten fittings, regular inspections should be carried out.
  - Do not place on a wet or damp floor as staining may occur to your floor.

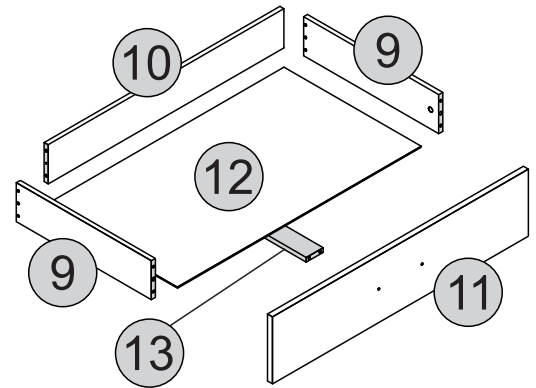
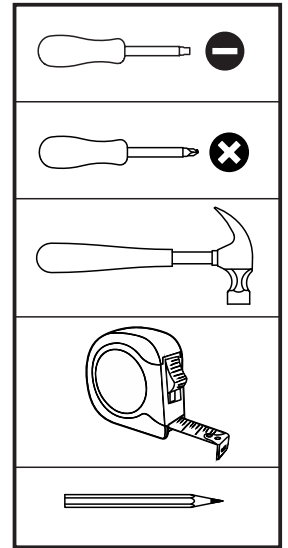
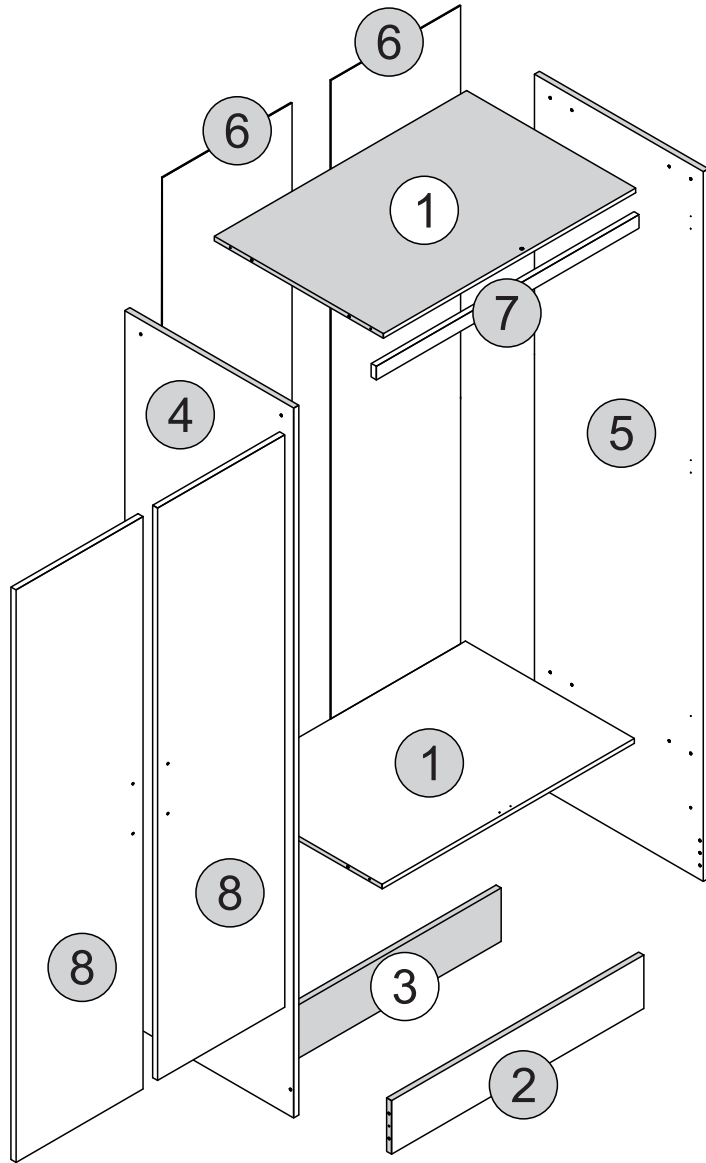











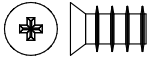
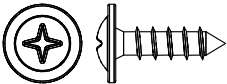
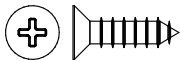
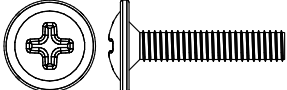

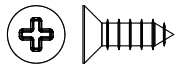
### PARTS LIST

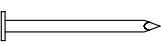
**Please Note:**  
The below parts have all been stamped with the part number to help identify them during assembly.

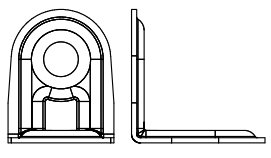
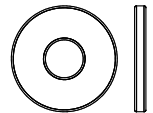
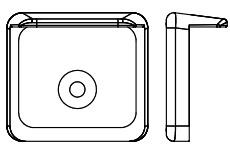
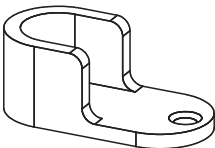
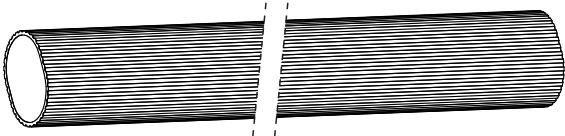
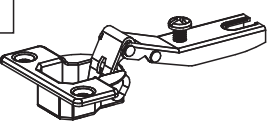
Part Number	Part Code	Part Description	Quantity	Carton
01	S100-101-128-DM1-01	Base-Top Panel	2	1/2
02	S100-101-128-DM1-02	Front Baseboard	1	2/2
03	S100-101-128-DM1-03	Back Baseboard	1	2/2
04	S100-101-128-DM1-04	Left Side Panel	1	1/2
05	S100-101-128-DM1-05	Right Side Panel	1	1/2
06	S100-101-128-DM1-06	Back Panel	2	1/2
07	S100-101-128-DM1-07	Frame	1	2/2
08	S100-101-128-DM1-08	Door	2	2/2
09	S100-101-128-DM1-09	Drawer Side	2	1/2
10	S100-101-128-DM1-10	Drawer Back Panel	1	2/2
11	S100-101-128-DM1-11	Drawer Front	1	2/2
12	S100-101-128-DM1-12	Drawer Bottom	1	1/2
13	S100-101-128-DM1-13	Drawer Bottom Support Bar	1	2/2

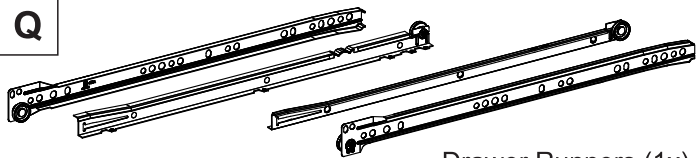
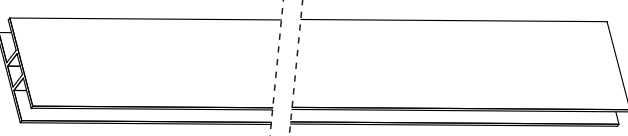
# FITTINGS LIST

SEC/SW/03/21/DM1

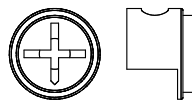
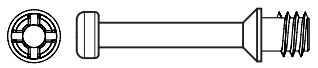
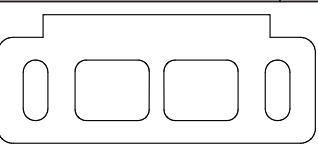
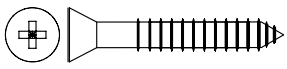
<p><b>A</b></p>  <p>Flat Head Screw Ø6,0 x 8mm (4x)</p> <p>1/+</p>	<p><b>B</b></p>  <p>Flan Head Screw Ø3,5 x 12mm (10x)</p> <p>1/+</p>	<p><b>C</b></p>  <p>Flat Head Screw Ø4,0 x 14mm (34x)</p> <p>2/+</p>	<p><b>D</b></p>  <p>Flan Head Screw Ø4,0 x 20mm (6x)</p> <p>1/+</p>
<p><b>E</b></p>  <p>Flat Head Screw Ø4,0 x 45mm (14x)</p> <p>2/+</p>	<p><b>F</b></p>  <p>Flat Head Screw Ø4,0 x 12mm (8x)</p> <p>1/+</p>	<p><b>G</b></p>  <p>2/+ Dowel Ø6,0 x 30mm (26x)</p>	
<p><b>H</b></p>  <p>Nail 10 x 10 (65x)</p> <p>5/+</p>	<p><b>I</b></p>  <p>Flan Head Screw Ø3,5 x 30mm (2x)</p> <p>1/+</p>	<p><b>J</b></p>  <p>1/+ 'L' Metallic Support (4x)</p>	<p><b>K</b></p>  <p>Washer (4x)</p> <p>1/+</p>
<p><b>L</b></p>  <p>Plastic Foot (6x)</p> <p>1/+</p>	<p><b>M</b></p>  <p>Hanging Rail Support (2x)</p>	<p><b>N</b></p>  <p>Hanging Rail (1x)</p>	
<p><b>O</b></p>  <p>Hinge (6x)</p>	<p><b>P</b></p>  <p>Hinge Plate (6x)</p>	<p><b>Q</b></p>  <p>Drawer Runners (1x)</p>	
<p><b>R</b></p>  <p>Back Panel Strip (1x)</p>		<p><b>S</b></p>  <p>Strap (2x)</p>	<p><b>T</b></p>  <p>Handle (3x)</p>
<p><b>U</b></p>  <p>Hole Plugs (16x)</p> <p>2/+</p>	<p><b>V</b></p>  <p>Glue (2x)</p>	<p><b>W</b></p>  <p>Cam Nut (2x)</p> <p>1/+</p>	<p><b>X</b></p>  <p>Cam Bolt (2x)</p> <p>1/+</p>
<p><b>Y</b></p>  <p>Door Support (2x)</p>	<p><b>Z</b></p>  <p>Flat Head Screw Ø3,5 x 25mm (1x)</p> <p>1/+</p>		

## TIPS FOR FITTINGS CAM-LOCKS

WHEN FITTING CAM NUT, ENSURE STARTING POSITION IS CORRECT BEFORE YOU INSERT CONNECTING CAM BOLT TURN CLOCKWISE UNTIL SECURE



✓

↑

CORRECT



✗

↑

WRONG

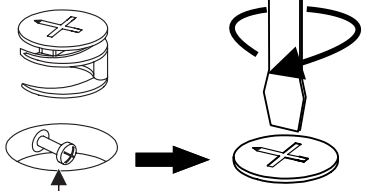

**Cam bolt head needs to be in centre**

### CAMBOLT

Tighten until shoulder is flush with panel. Do not overtighten or undertighten (see example beside)

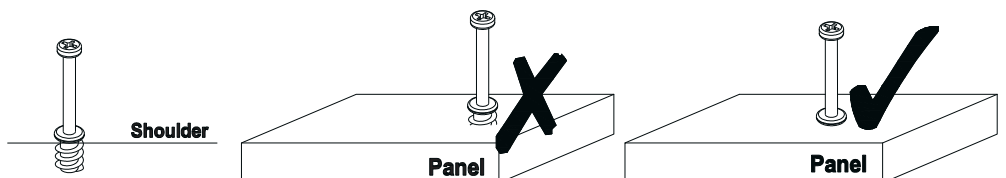

# STEP 1

## PARTS REQUIRED

4 - LEFT SIDE PANEL x1

## HARDWARE REQUIRED

A  02  
Ø6,0 x 8mm

H  02  
10 x 10

L  02

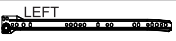
Q  01

## TOOLS REQUIRED

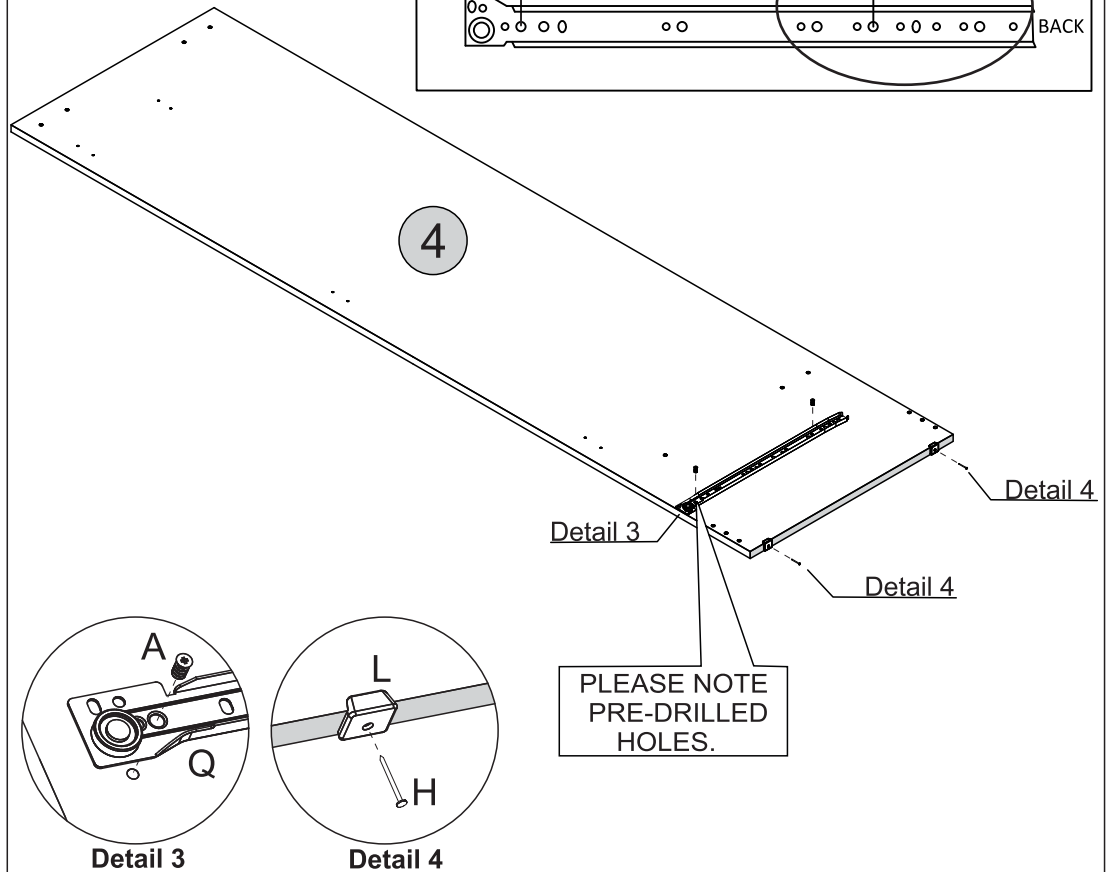
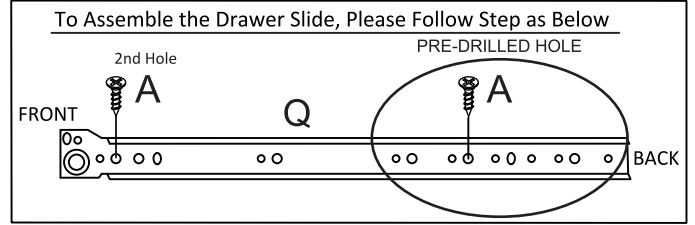
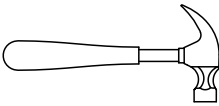
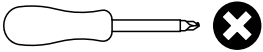



# STEP 2

## PARTS REQUIRED

5 - RIGHT SIDE PANEL x1

## HARDWARE REQUIRED

A  02  
Ø6,0 x 8mm

H  02  
10 x 10

L  02

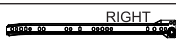
Q  01

## TOOLS REQUIRED

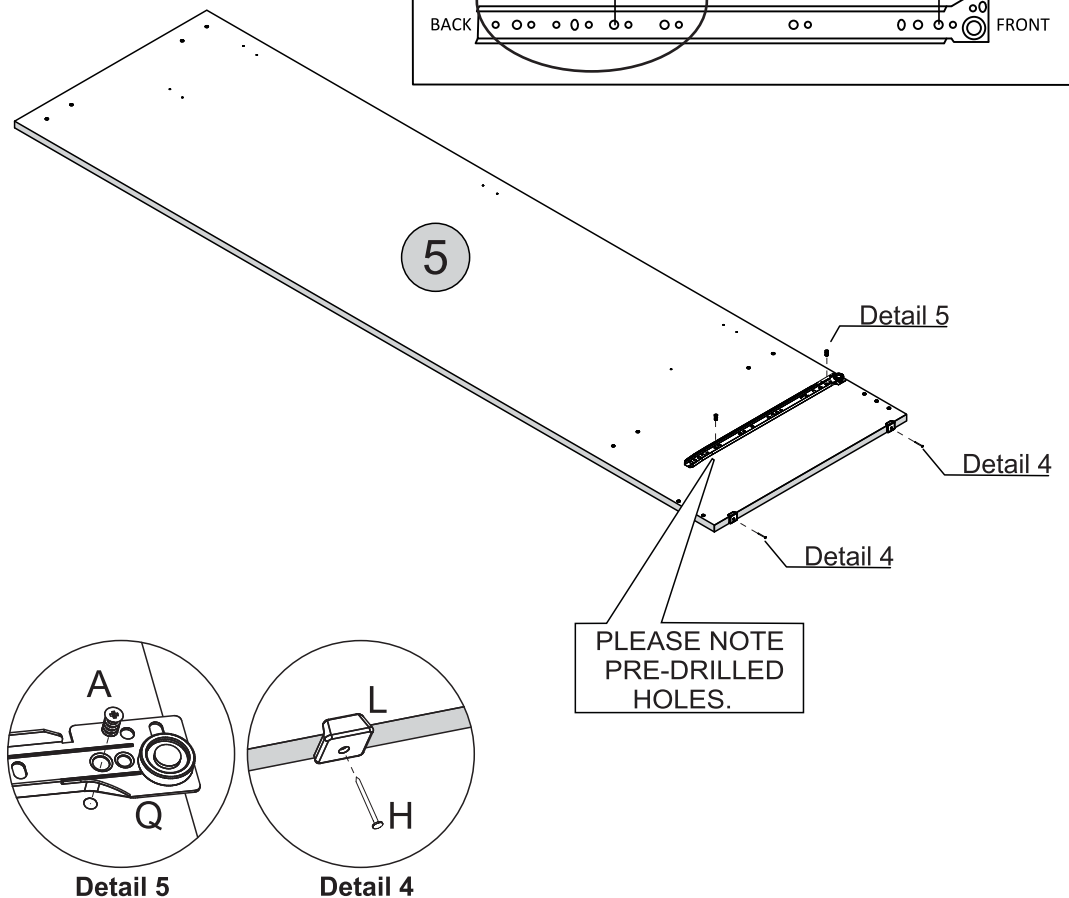
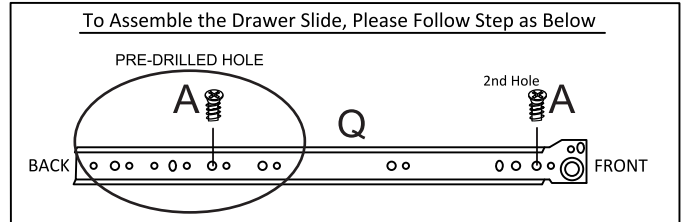
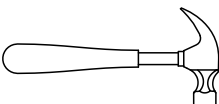
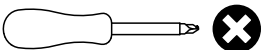

# STEP 3

## PARTS REQUIRED

4 - LEFT SIDE PANEL x1

## HARDWARE REQUIRED

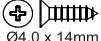
C  08  
Ø4,0 x 14mm

M  01

P  03

## TOOLS REQUIRED

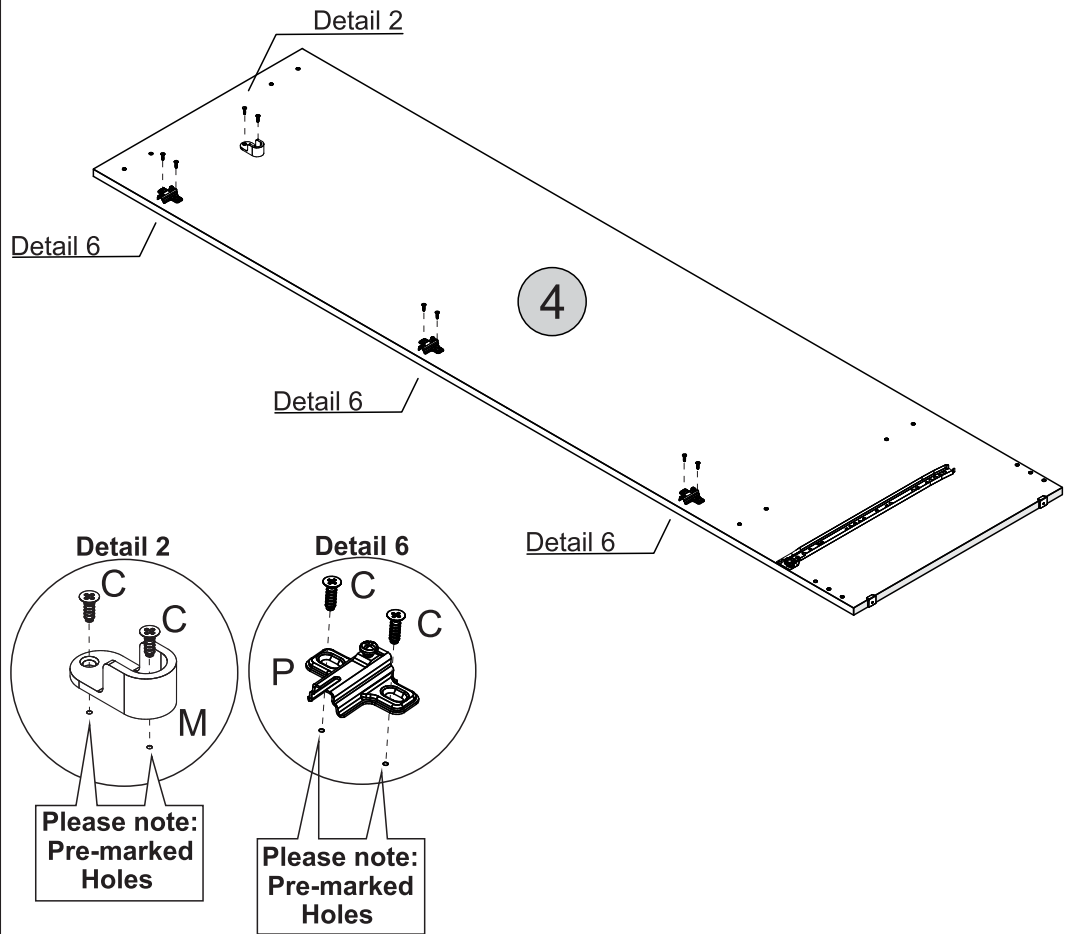
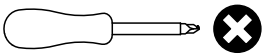

# STEP 4

## PARTS REQUIRED

5 - RIGHT SIDE PANEL x1

## HARDWARE REQUIRED

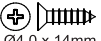
C  08  
Ø4,0 x 14mm

M  01

P  03

## TOOLS REQUIRED

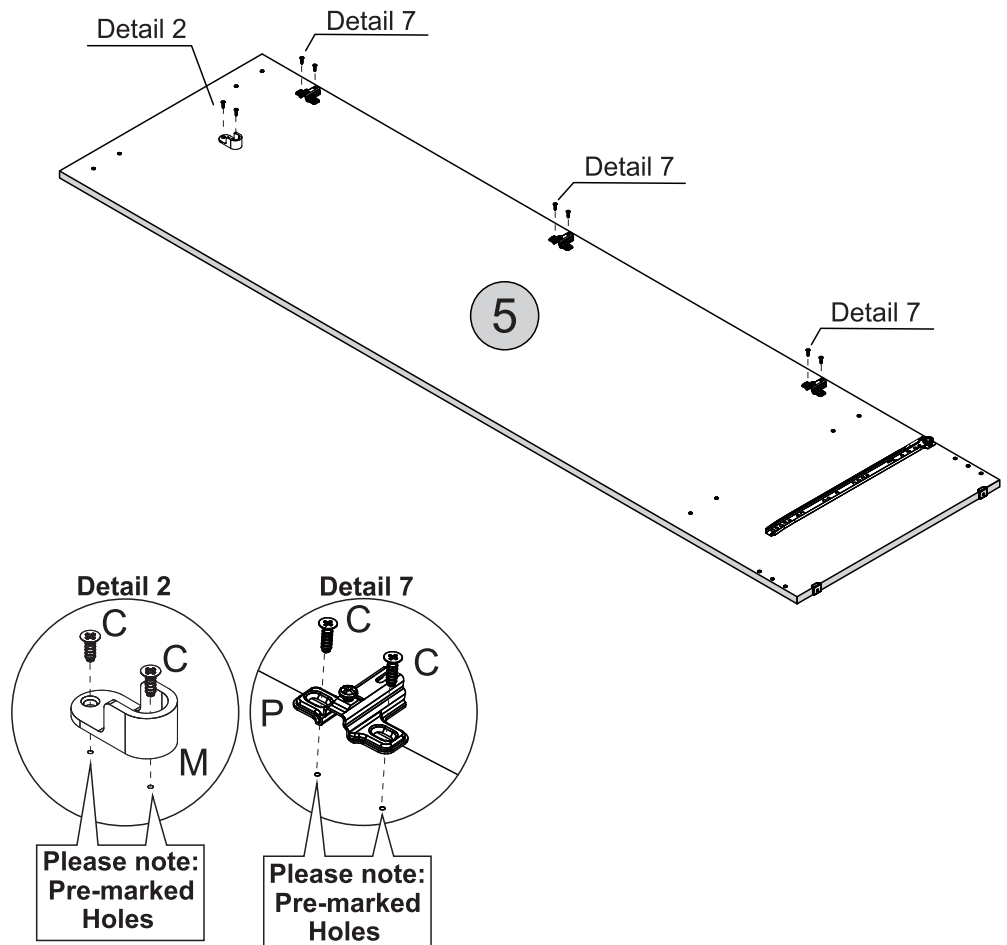
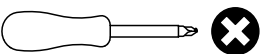



# STEP 7

## PARTS REQUIRED

1A - BASE PANEL x1

1B - TOP PANEL x1

5 - RIGHT SIDE PANEL x1

## HARDWARE REQUIRED

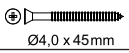
E  04  
Ø4,0 x 45mm

V  01

## TOOLS REQUIRED

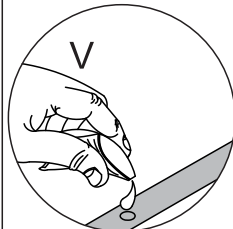
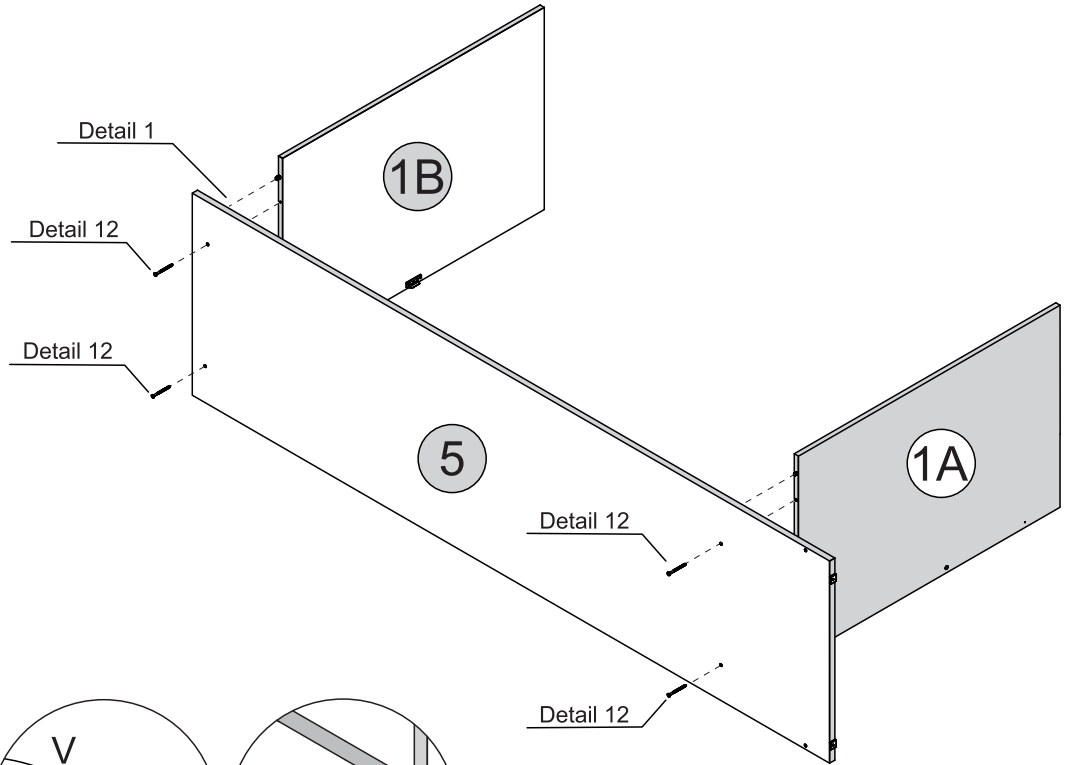
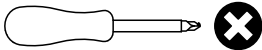

Detail 1

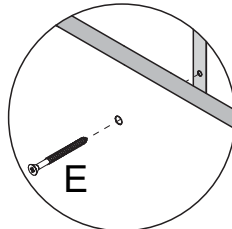

Detail 12

# STEP 8

## PARTS REQUIRED

2 - FRONT BASEBOARD x1

3 - BACK BASEBOARD x1

4 - LEFT SIDE PANEL x1

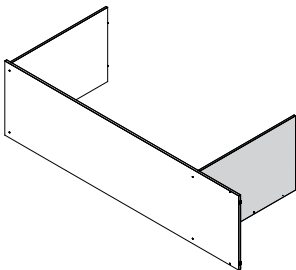

## HARDWARE REQUIRED

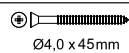
E  08  
Ø4,0 x 45mm

V  01

## TOOLS REQUIRED

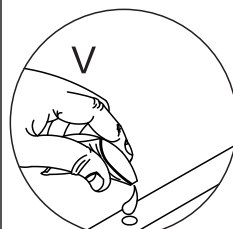
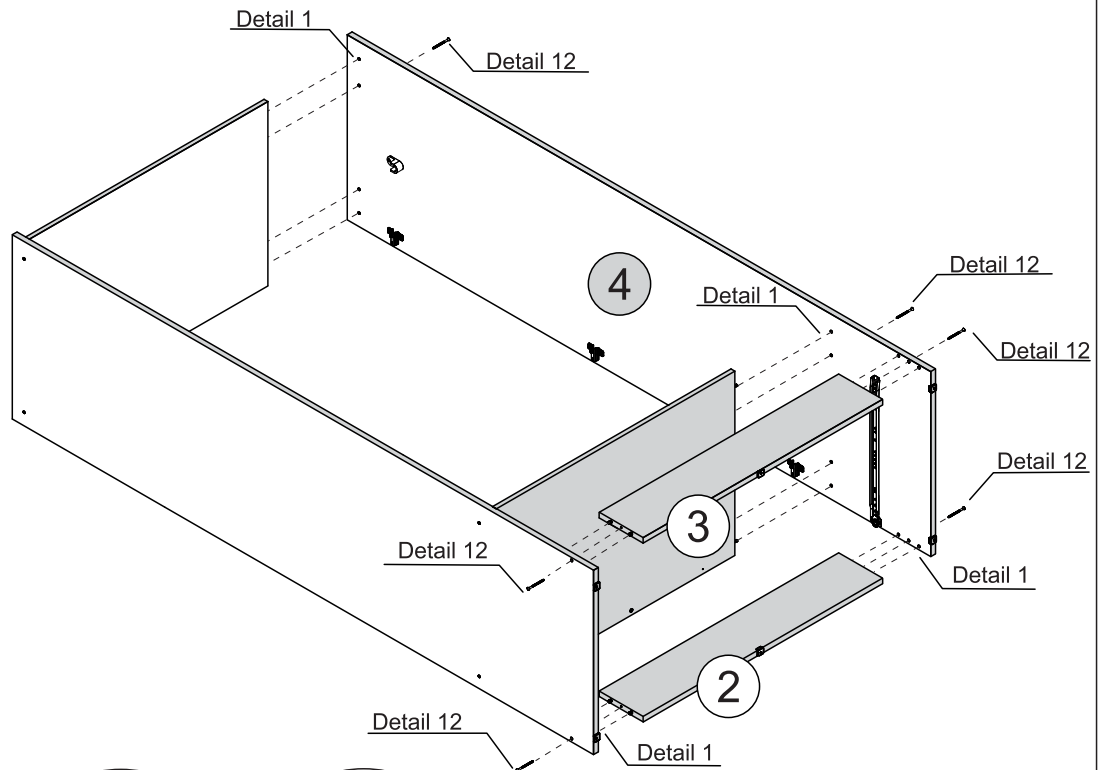
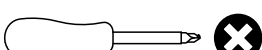

Detail 1

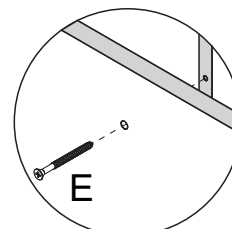

Detail 12

# STEP 9

### PARTS REQUIRED

### HARDWARE REQUIRED

### TOOLS REQUIRED

6 - BACK PANEL x2

H  40

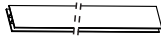
R  01

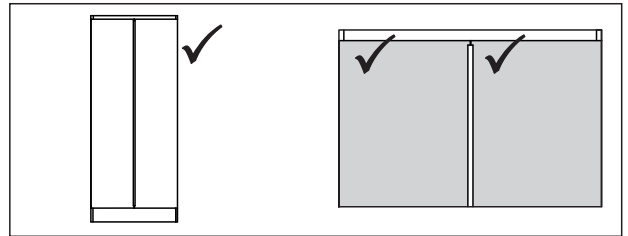
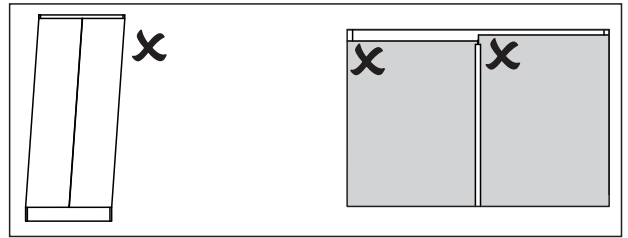
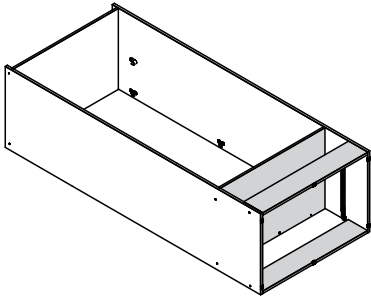
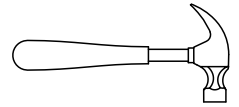

\* For your future reference  
Order Number should be here

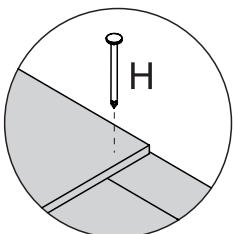
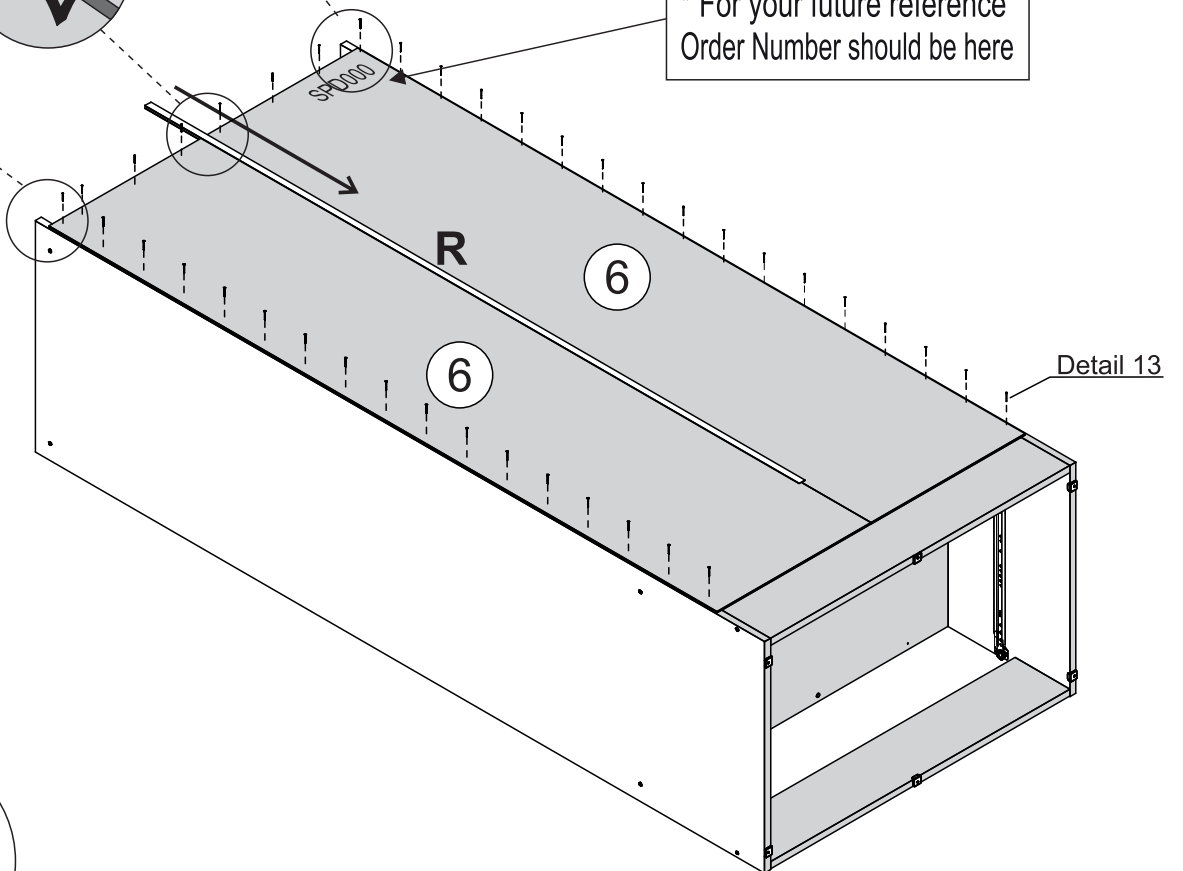
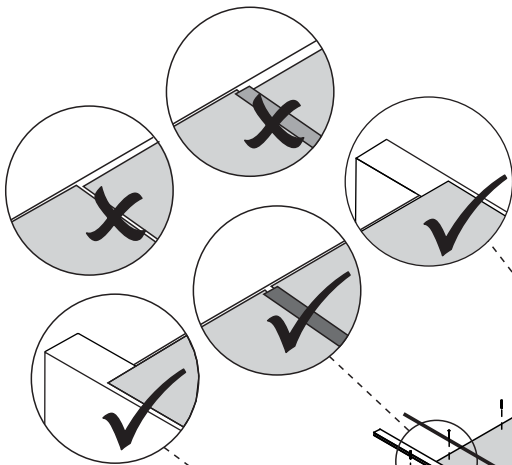

Detail 13



# STEP 10

SEC/SW/03/21/DM1

## PARTS REQUIRED

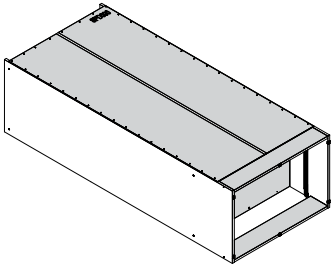

## HARDWARE REQUIRED

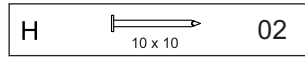

## TOOLS REQUIRED

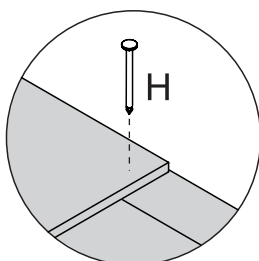
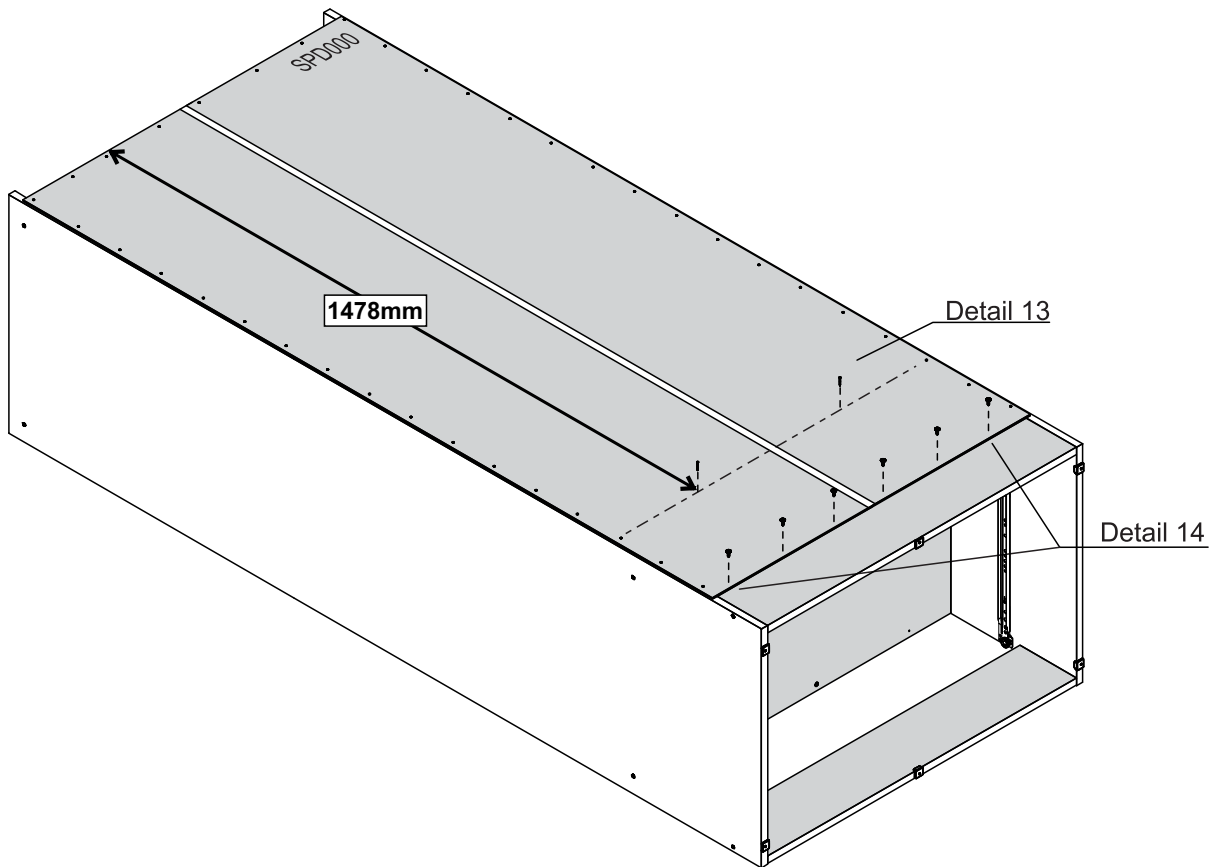
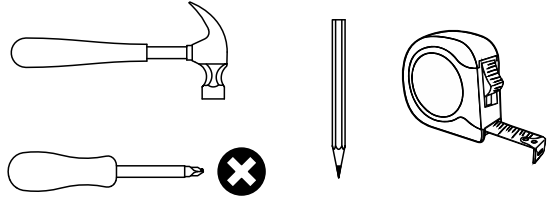

Detail 13

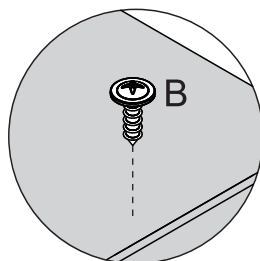

Detail 14

# STEP 11

**PARTS REQUIRED**

7 - FRAME x1

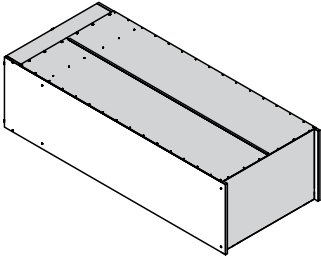

**HARDWARE REQUIRED**

J  02

F  06  
Ø4,0 x 12mm

**TOOLS REQUIRED**

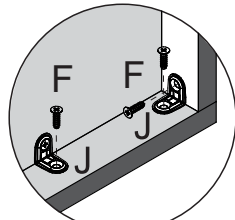
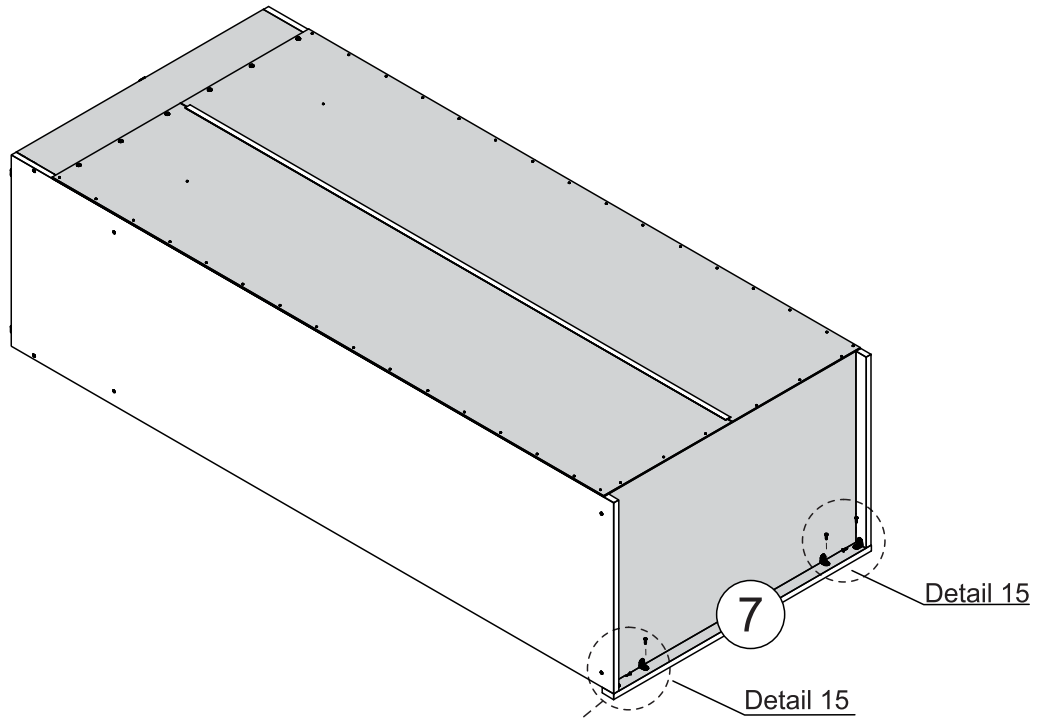
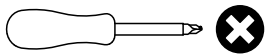

Detail 15

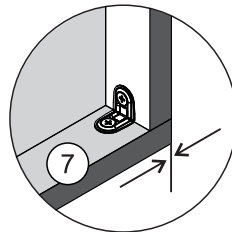

Align corners

# STEP 12

**PARTS REQUIRED**

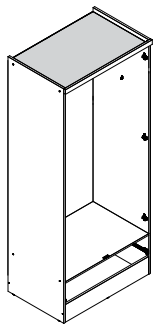

**HARDWARE REQUIRED**

N  01

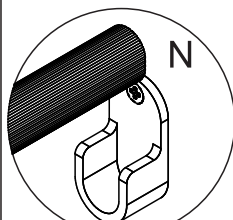
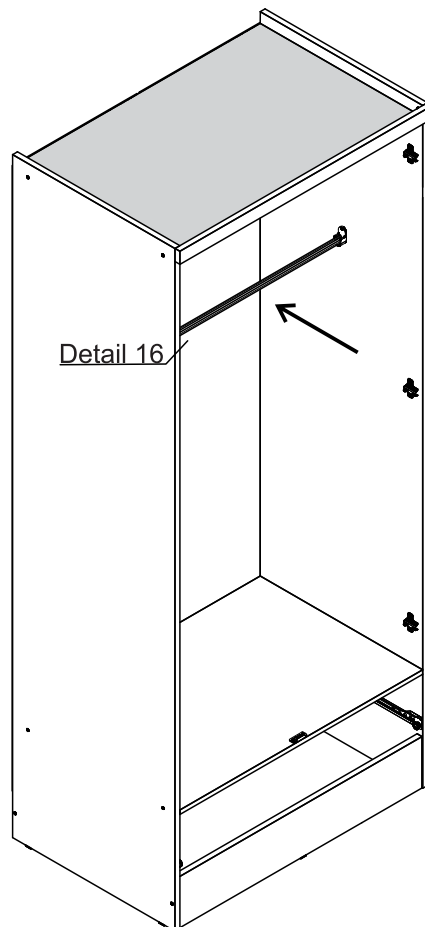



Detail 16

# STEP 13

## PARTS REQUIRED

- 9 - DRAWER SIDE x2
- 10 - DRAWER BACK PANEL x1
- 11 - DRAWER FRONT x1
- 13 - DRAWER BOTTOM SUPPORT BAR x1

## HARDWARE REQUIRED

- G  10  
Ø6,0 x 30mm
- V  01  
Glue
- X  02

## TOOLS REQUIRED

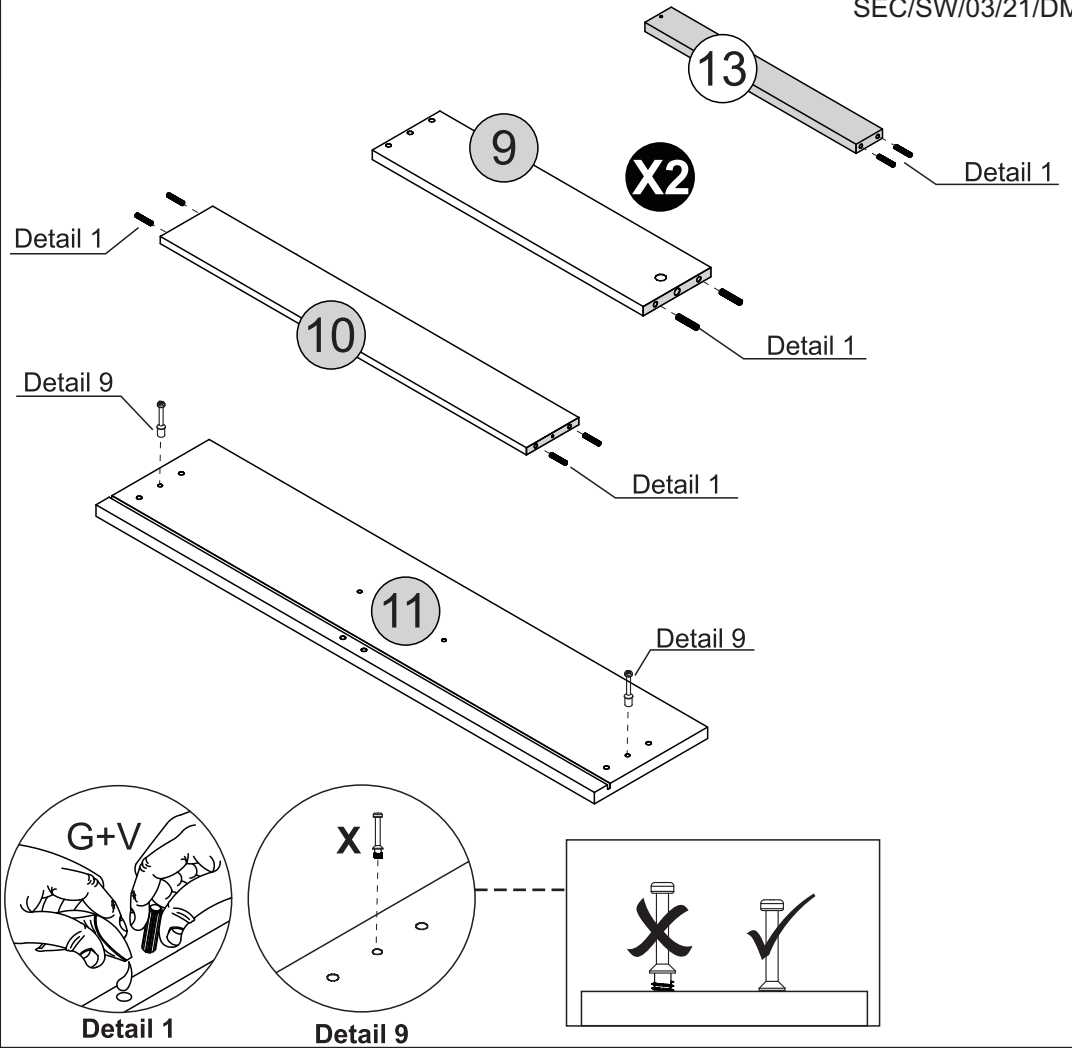
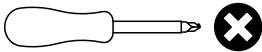

# STEP 14

## PARTS REQUIRED

- 9 - DRAWER SIDE x2
- 10 - DRAWER BACK PANEL x1

## HARDWARE REQUIRED

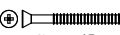
- E  02  
Ø4,0 x 45mm

## TOOLS REQUIRED

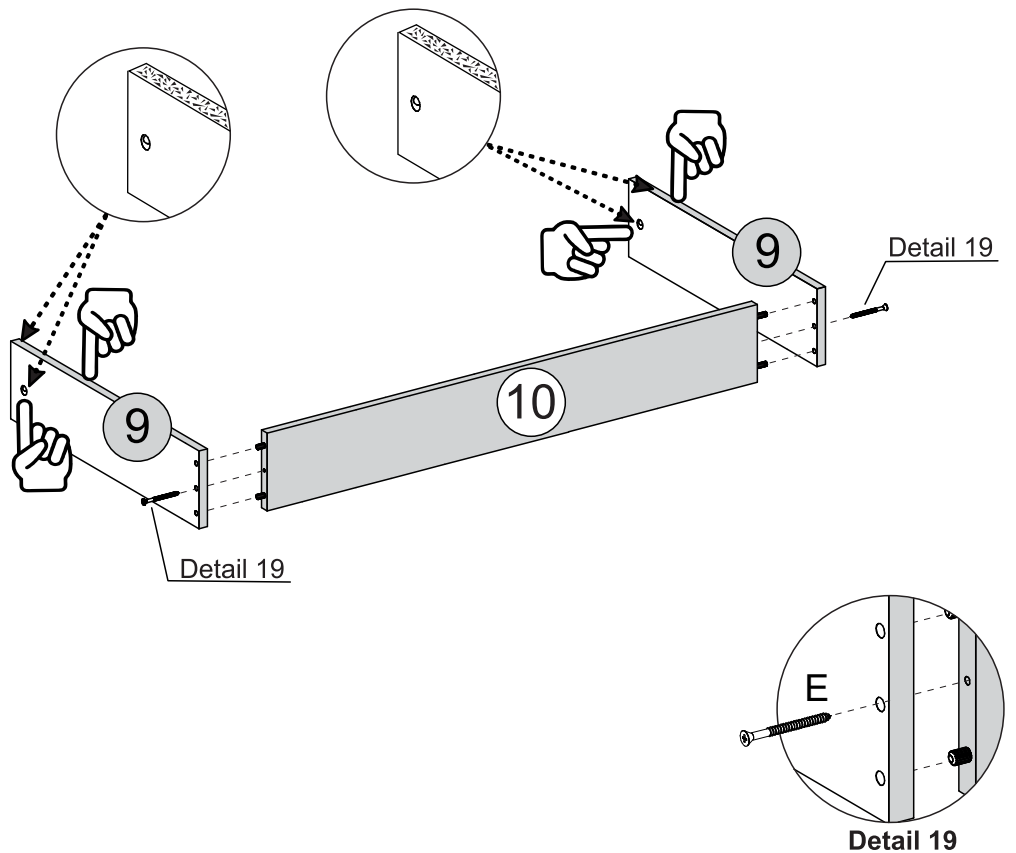
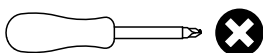

# STEP 15

**PARTS REQUIRED**

11 - DRAWER FRONT x1

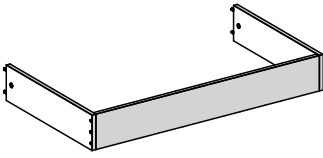

**HARDWARE REQUIRED**

V  01

**TOOLS REQUIRED**

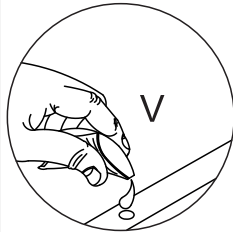

Detail 1

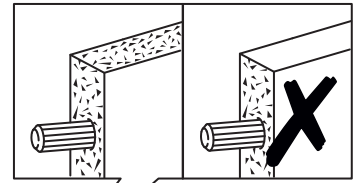
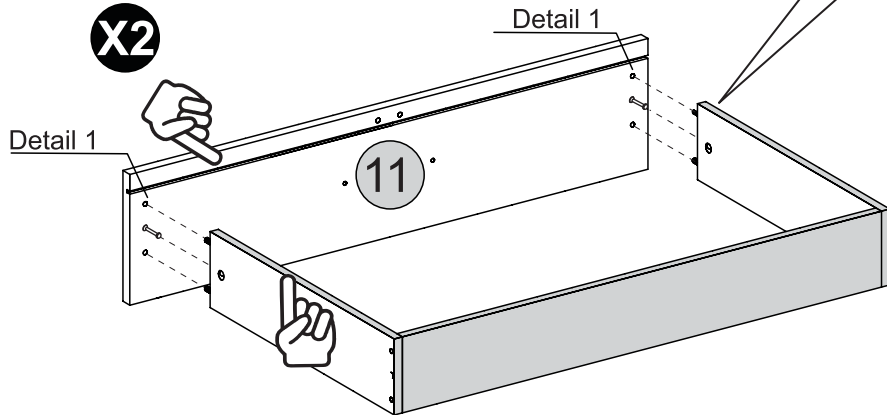

# STEP 16

**PARTS REQUIRED**

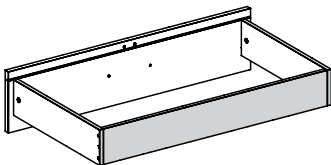

**HARDWARE REQUIRED**

U  04

W  02

**TOOLS REQUIRED**

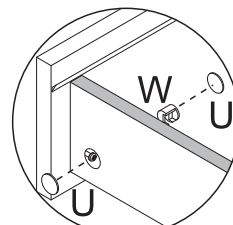
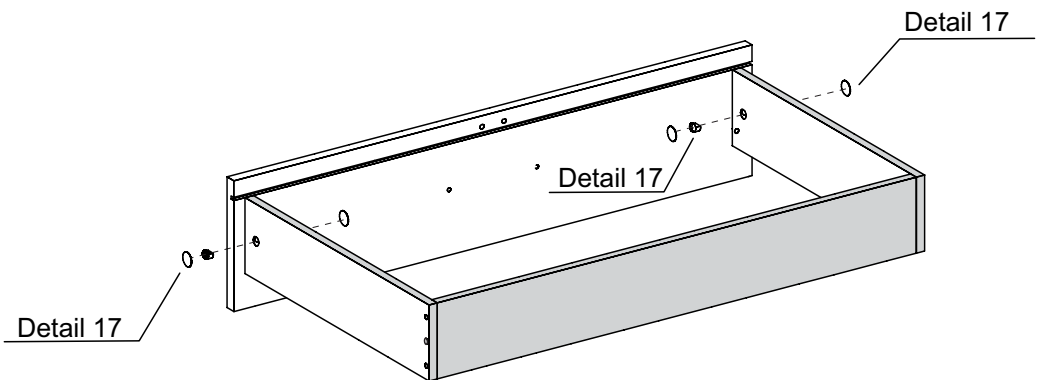
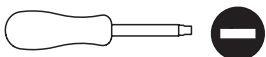

Detail 17

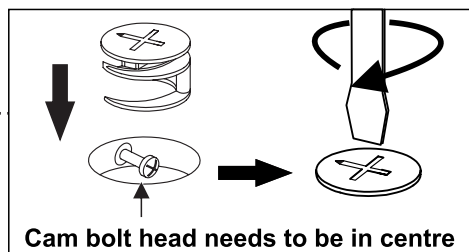

# STEP 17

**PARTS REQUIRED**

12 - DRAWER BOTTOM x1

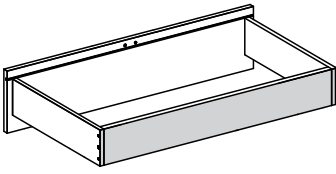

**HARDWARE REQUIRED**

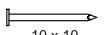
H  04

**TOOLS REQUIRED**

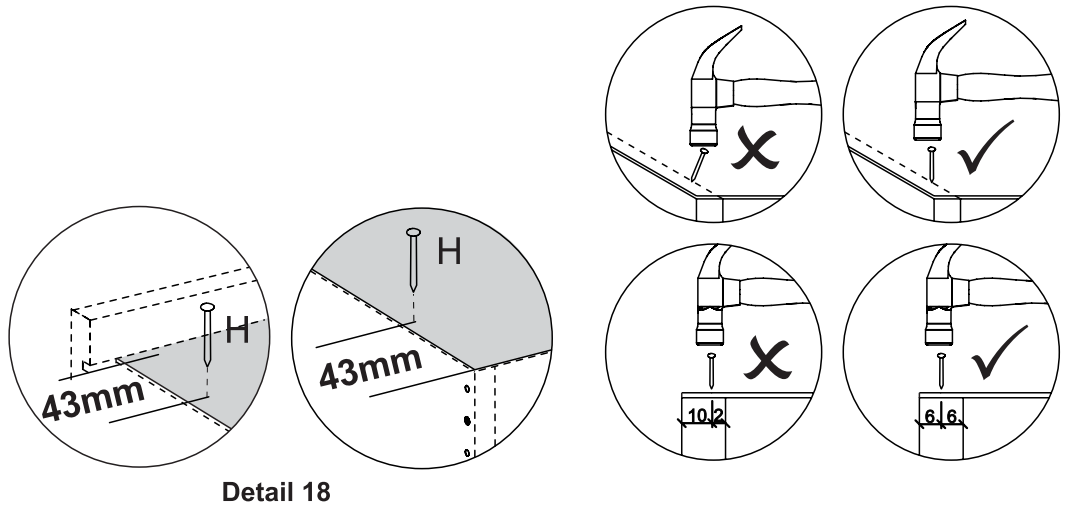
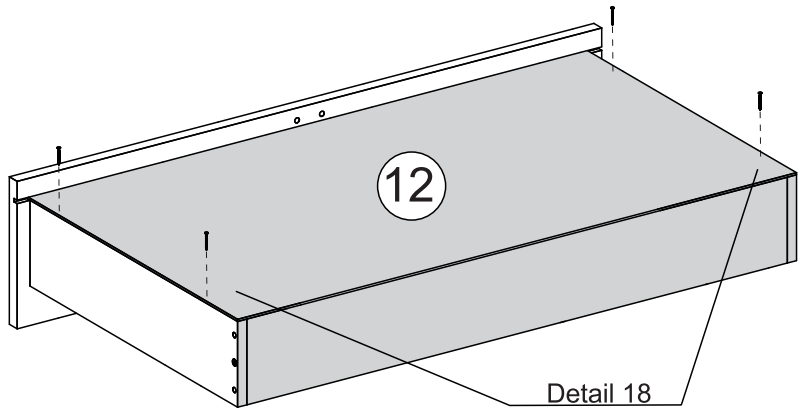
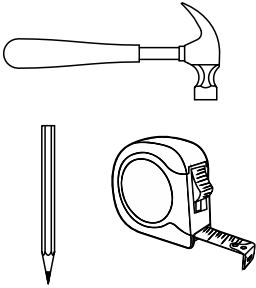

# STEP 18

**PARTS REQUIRED**

13 - DRAWER BOTTOM SUPPORT BAR x1

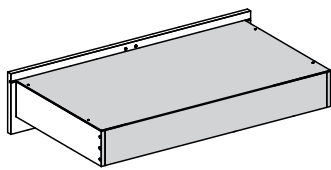

**HARDWARE REQUIRED**

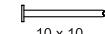
H  06

**TOOLS REQUIRED**

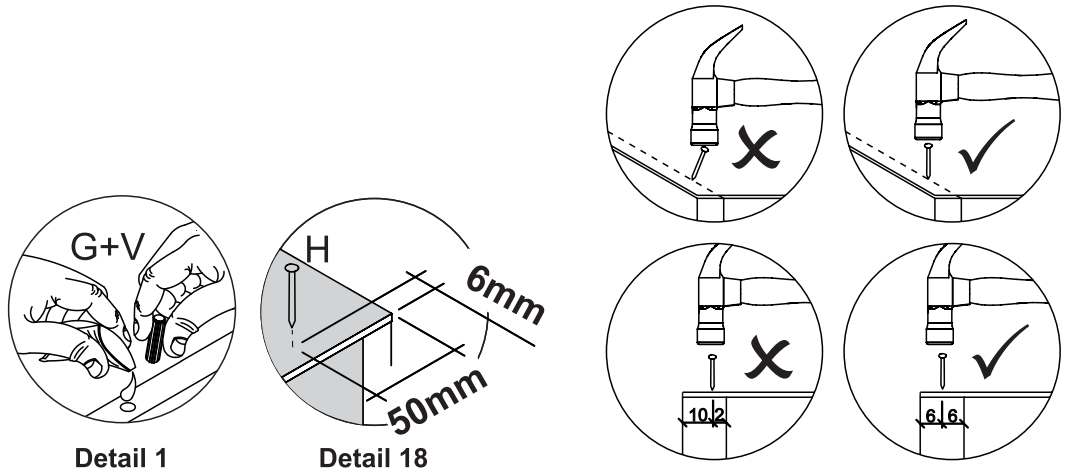
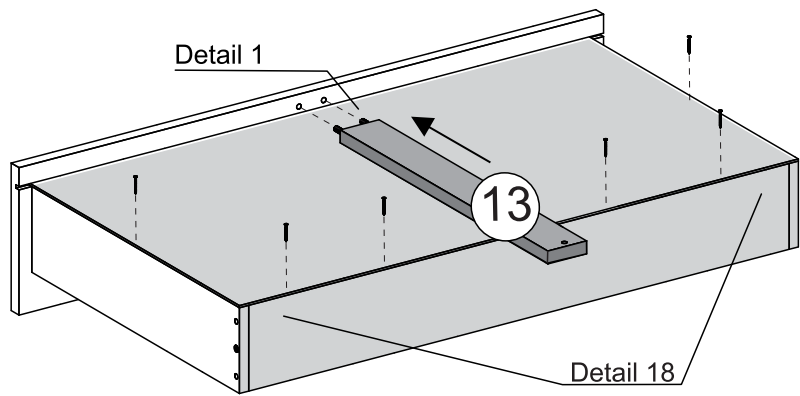
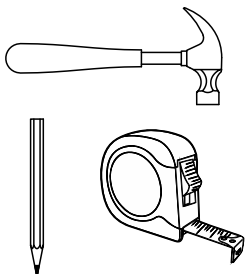

# STEP 19

**PARTS REQUIRED**

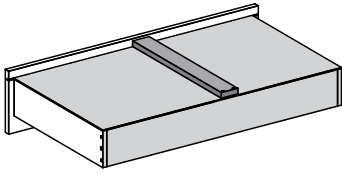

**HARDWARE REQUIRED**

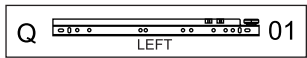
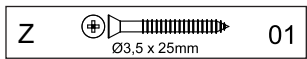
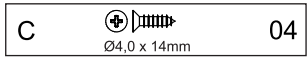

**TOOLS REQUIRED**

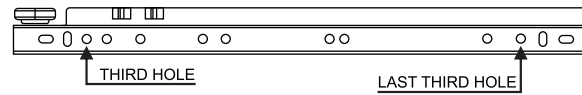
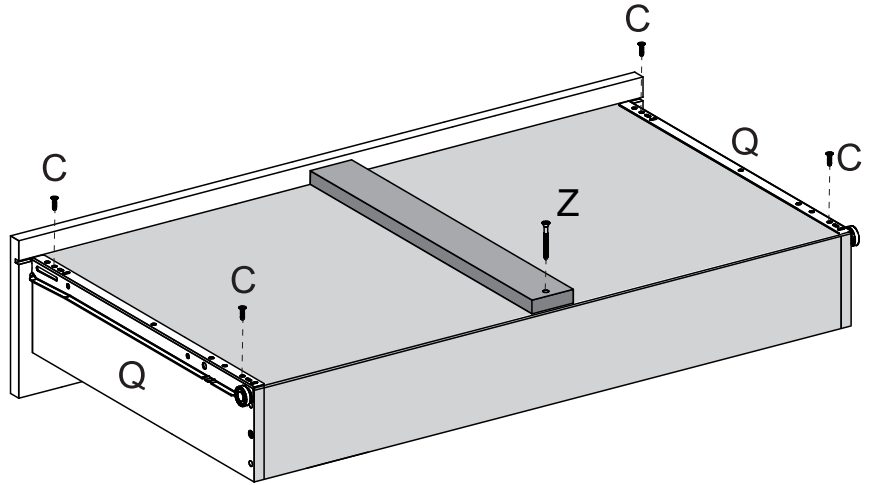
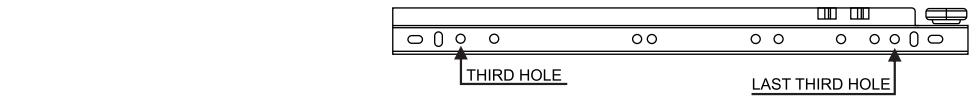
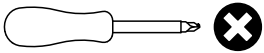

# STEP 20

**PARTS REQUIRED**



**HARDWARE REQUIRED**

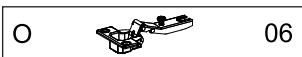
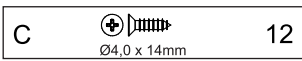

**TOOLS REQUIRED**

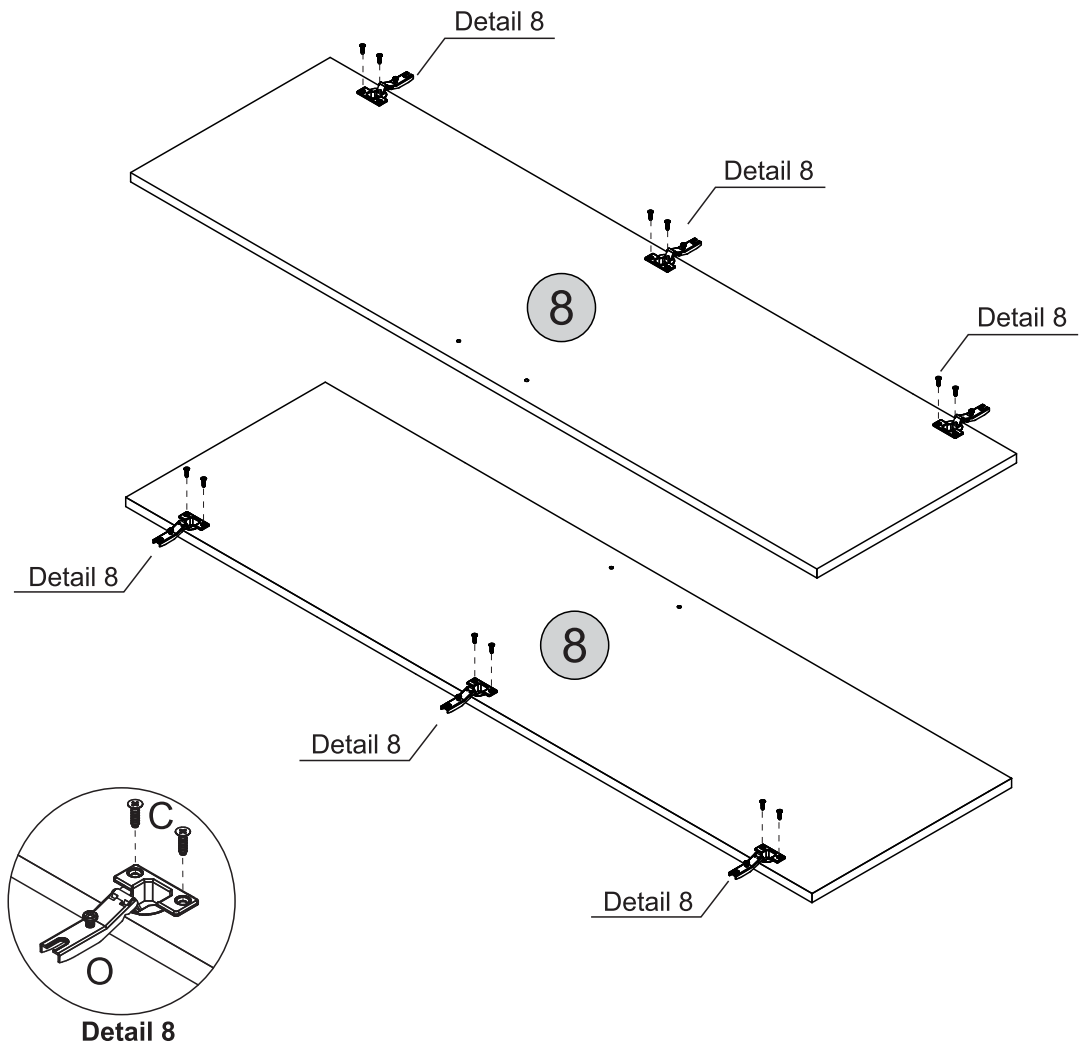
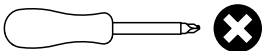

# STEP 21

**PARTS REQUIRED**

8 - DOOR x2

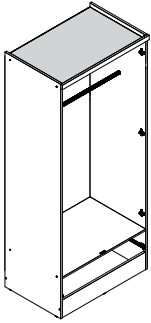

**HARDWARE REQUIRED**

U  12

**TOOLS REQUIRED**

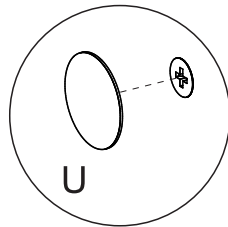
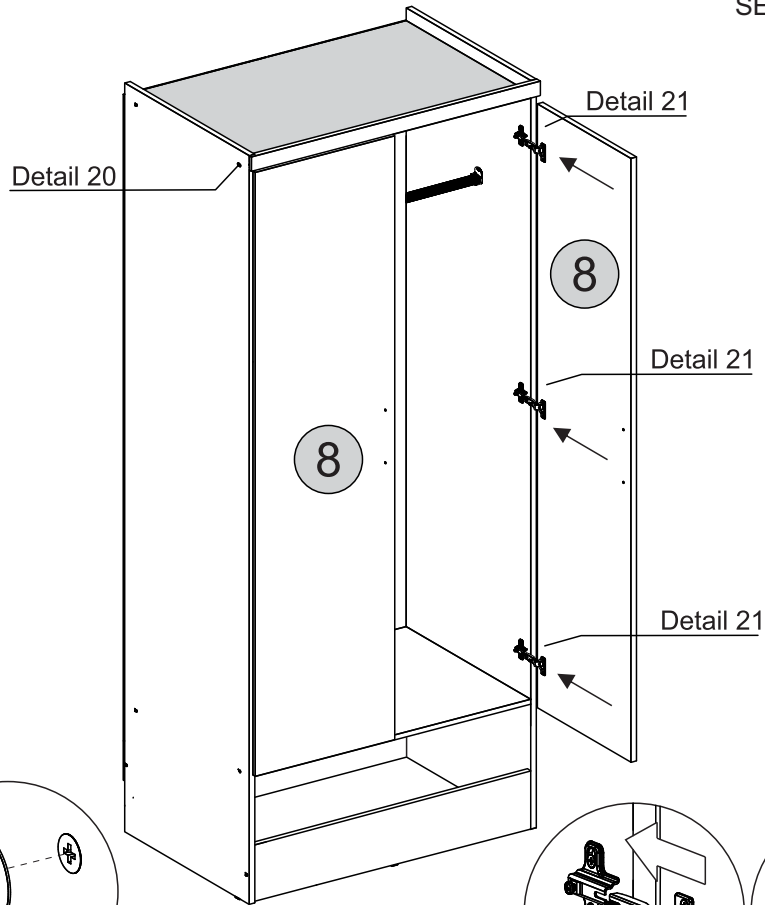
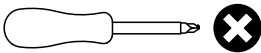

Detail 20

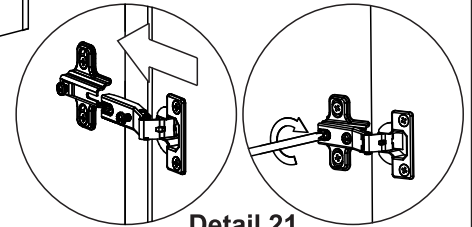

Detail 21

# STEP 22

**PARTS REQUIRED**

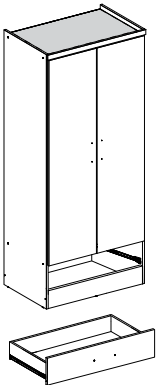

**HARDWARE REQUIRED**

D  06  
Ø4.0 x 20mm

T  03

**TOOLS REQUIRED**

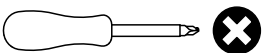

  
See the last page

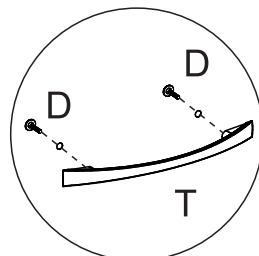
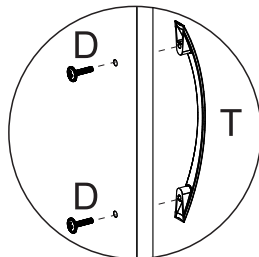
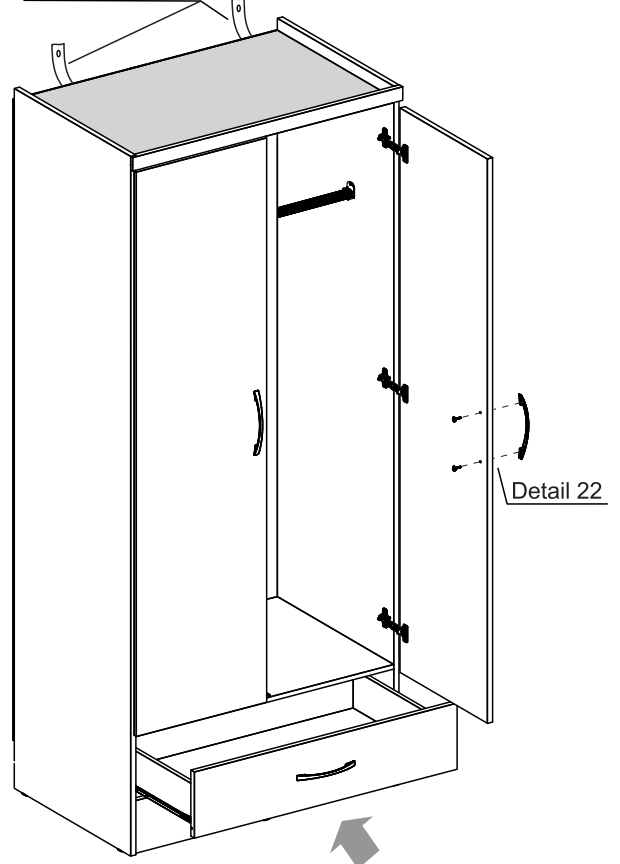

Detail 22

# STEP 23

## PARTS REQUIRED

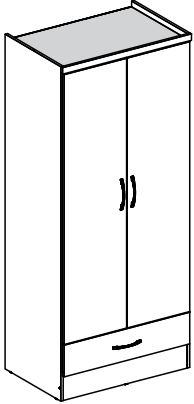

## HARDWARE REQUIRED

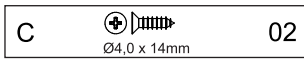

## TOOLS REQUIRED

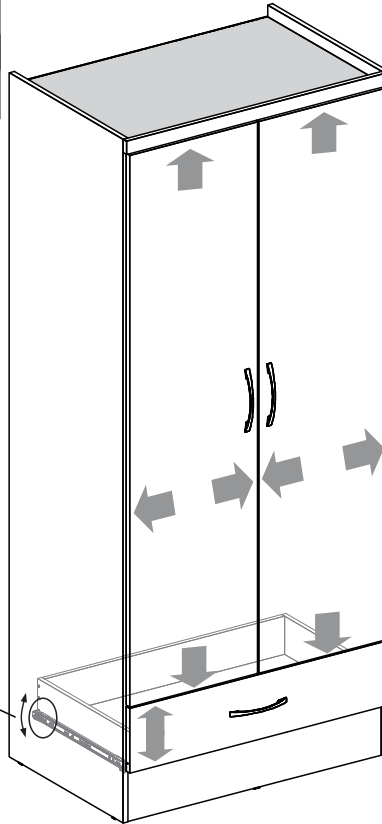
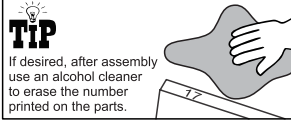
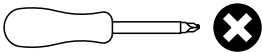

Detail 23

### Drawer Adjustment

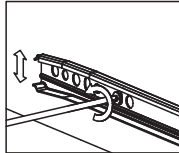

### Drawer Lock

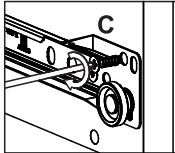

Detail 23

### Height Adjustment

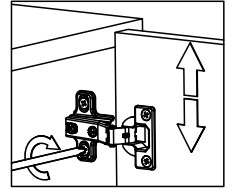

### Internal Adjustment

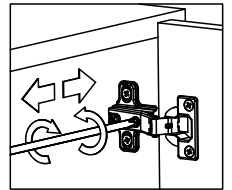

### Depth Adjustment

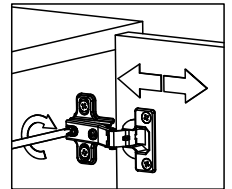
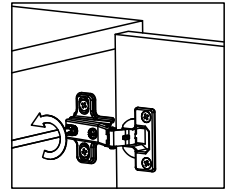

# WARNING

**Serious or fatal injuries can occur from furniture tipping over. To prevent the furniture from tipping over we recommend that it is permanently fixed to the wall.**

Wall fixings are not supplied with this product as different wall materials require different types of fixing devices.

Please make sure you use fixings suitable for the walls in your home.

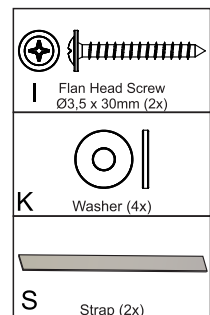
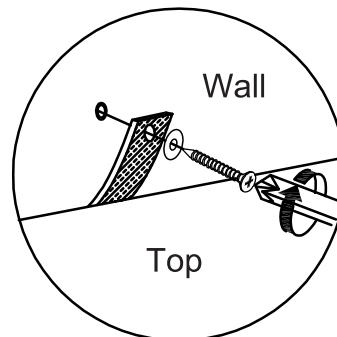
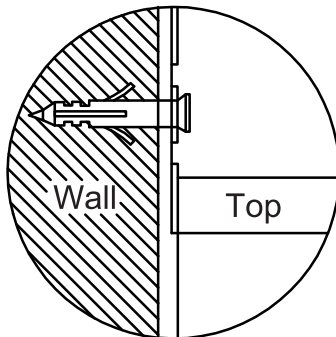
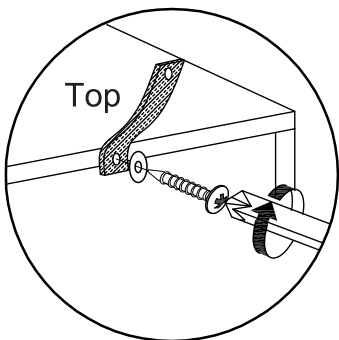



# NEVADA 3+2 DRAWER CHEST BLACK WOOD GRAIN ASSEMBLY INSTRUCTIONS

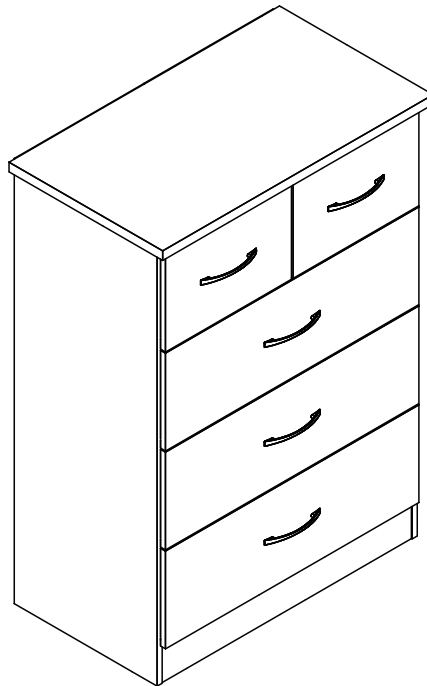

## IMPORTANT

### FOR DOMESTIC USE ONLY

PLEASE READ BEFORE YOU CONTINUE FURTHER

## CARE AND MAINTENANCE

After unpacking this product please keep the original packaging in case it needs to be returned for any reason.

- Please ensure all fittings and parts are present before commencing with assembly.
- Never drag or push products as this could cause damage to the joints making it inferior.
- We strongly recommend that you keep children away from your work area.
- We recommend that you lay a blanket or sheet on the floor to avoid damage to both your floor and the product.
- Assemble this product as close to its final position as possible.
- Do not place this product next to a radiator or in direct sunlight.
- Do not drag or push items across your high gloss furniture as this may cause the surface to scratch
- Wood is a natural product and may expand if subjected to damp and may shrink or crack if subjected to heat. Therefore it is recommended that room temperature is maintained, with no sudden temperature fluctuations.
- Make sure any spillage is wiped off immediately.
- Do not place hot or chilled items directly on to the surface, use a place mat or marking will occur.
- For general cleaning use a soft cotton or micro fibre cloth, and do not use detergents of any kind.
- From time to time it may be necessary to tighten fittings, regular inspections should be carried out.
- Do not place on a wet or damp floor as staining may occur to your floor.

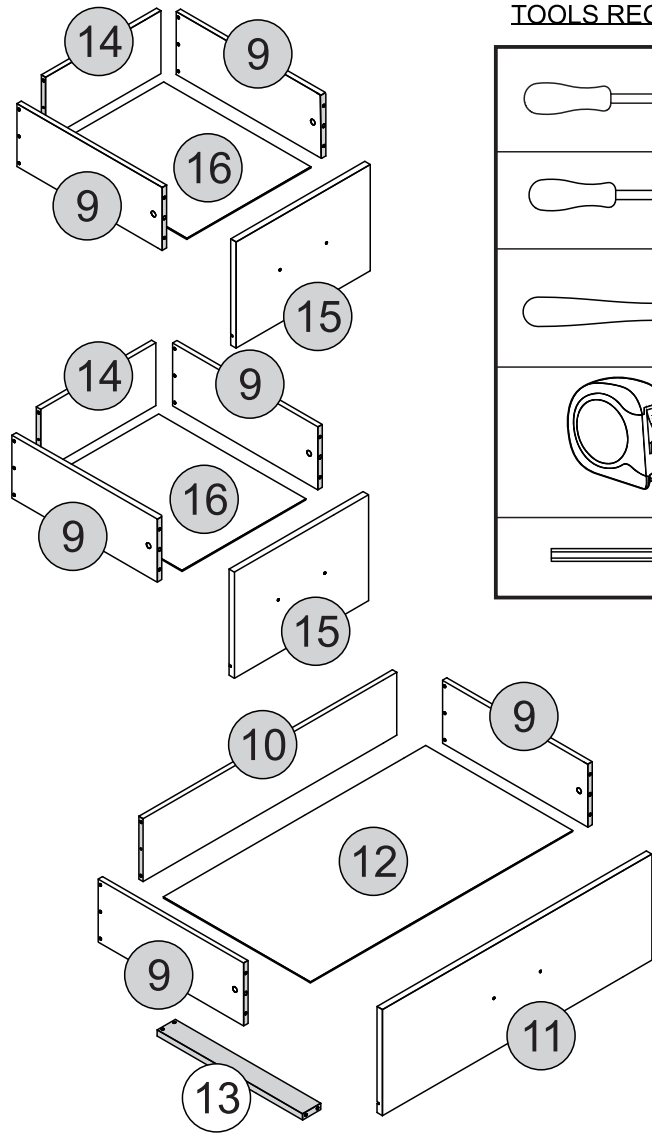
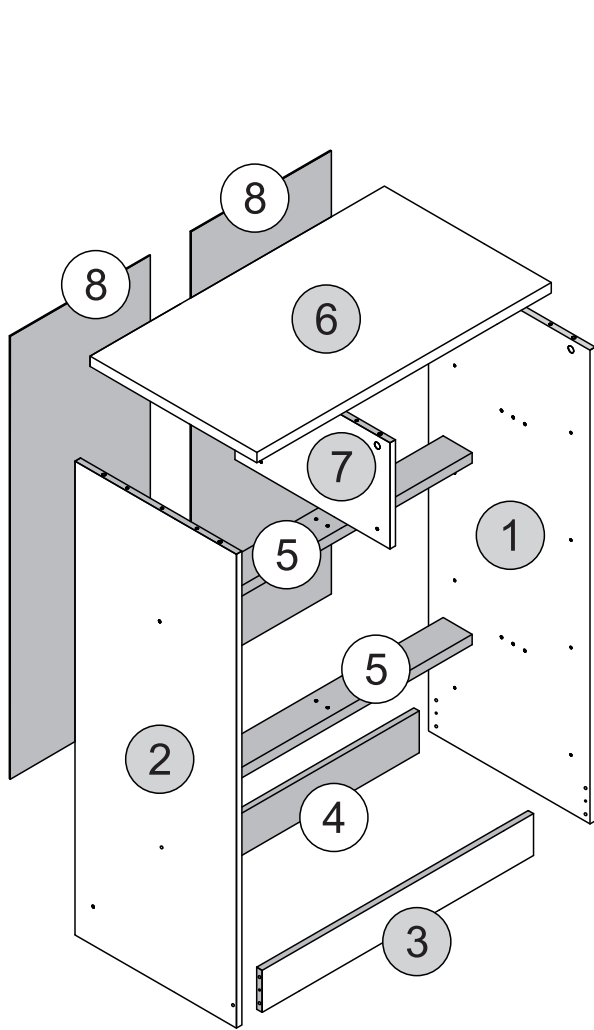

**TOOLS REQUIRED**

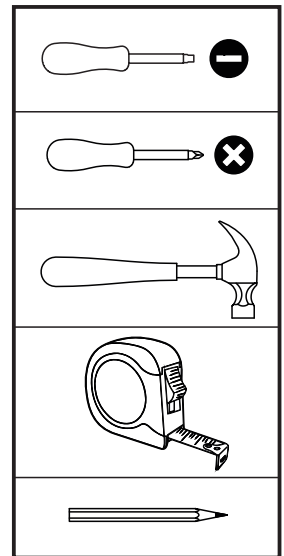









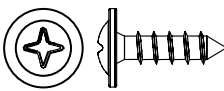
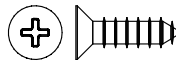
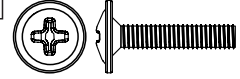
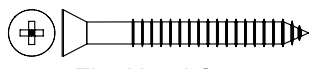

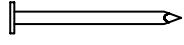
**PARTS LIST**

**Please Note:**  
The below parts have all been stamped with the part number to help identify them during assembly.

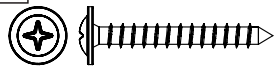
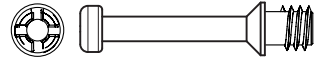
Part Number	Part Code	Part Description	Quantity	Carton
1	S100-102-145-DM1-01	Right Side Panel	1	1/2
2	S100-102-145-DM1-02	Left Side Panel	1	1/2
3	S100-102-145-DM1-03	Front Baseboard	1	1/2
4	S100-102-145-DM1-04	Back Baseboard	1	1/2
5	S100-102-145-DM1-05	Crossbar	2	2/2
6	S100-102-145-DM1-06	Top Panel	1	2/2
7	S100-102-145-DM1-07	Division Panel	1	1/2
8	S100-102-145-DM1-08	Back Panel	2	1/2
9	S100-102-145-DM1-09	Drawer Side	10	1/2
10	S100-102-145-DM1-10	Large Drawer Back Panel	3	1/2
11	S100-102-145-DM1-11	Large Drawer Front	3	2/2
12	S100-102-145-DM1-12	Large Drawer Bottom	3	2/2
13	S100-102-145-DM1-13	Drawer Bottom Support Bar	3	1/2
14	S100-102-145-DM1-14	Small Drawer Back Panel	2	1/2
15	S100-102-145-DM1-15	Small Drawer Front	2	2/2
16	S100-102-145-DM1-16	Small Drawer Bottom	2	1/2

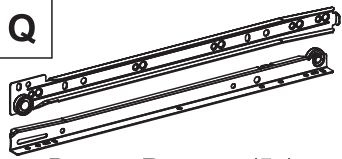
# FITTINGS LIST

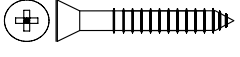
<b>A</b>  Flat Head Screw 2/+ Ø6,0 x 8mm (20x)	<b>B</b>  Flan Head Screw 1/+ Ø3,5 x 12mm (6x)	<b>C</b>  Flat Head Screw 2/+ Ø4,0 x 14mm (30x)	<b>D</b>  Flan Head Screw 2/+ Ø4,0 x 20mm (10x)
<b>E</b>  Flat Head Screw 2/+ Ø4,0 x 45mm (19x)	<b>F</b>  Handle (5x)	<b>G</b>  2/+ Dowel Ø6,0 x 30mm (65x)	<b>H</b>  2/+ Nail 10 x 10 (87x)
<b>I</b>  1/+ Back Panel Bracket (2x)	<b>J</b>  2/+ Cam Nut Ø12mm (16x)	<b>K</b>  1/+ Washer (4x)	<b>L</b>  1/+ Plastic Foot (6x)
<b>M</b>  1/+ Flan Head Screw Ø3,5 x 30mm (2x)	<b>N</b>  2/+ Cam Bolt (16x)	<b>O</b>  2/+ Hole Plugs (28x)	<b>P</b>  Glue (3x)
<b>Q</b>  Drawer Runners (5x)	<b>R</b>  Back Panel Strip (1x)	<b>S</b>  Strap (2x)	<b>T</b>  1/+ Flat Head Screw Ø3,5 x 25mm (3x)

## TIPS FOR FITTINGS CAM-LOCKS

WHEN FITTING CAM NUT. ENSURE STARTING POSITION IS CORRECT BEFORE YOU INSERT CONNECTING CAM BOLT TURN CLOCKWISE UNTIL SECURE

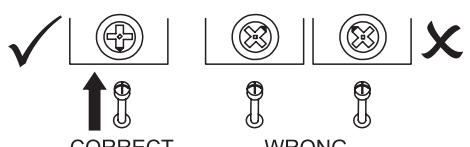

**CORRECT**      **WRONG**

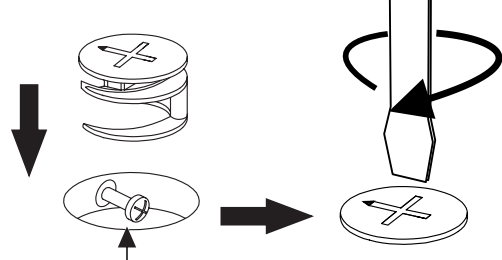

Cam bolt head needs to be in centre

### CAMBOLT

Tighten until shoulder in flush with panel. Do not overtighten or undertighten (see example beside)

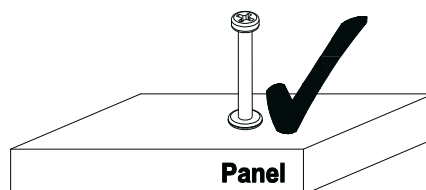
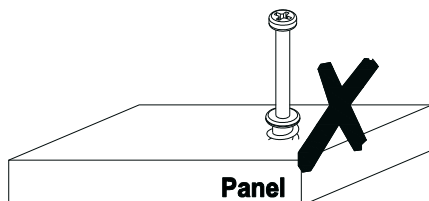
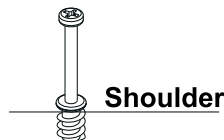



# STEP 1

## PARTS REQUIRED

2 - LEFT SIDE PANEL x1

## HARDWARE REQUIRED

G  02  
Ø6 x 30

H  02  
10 x 10

L  02

P  01  
GLUE

## TOOLS REQUIRED

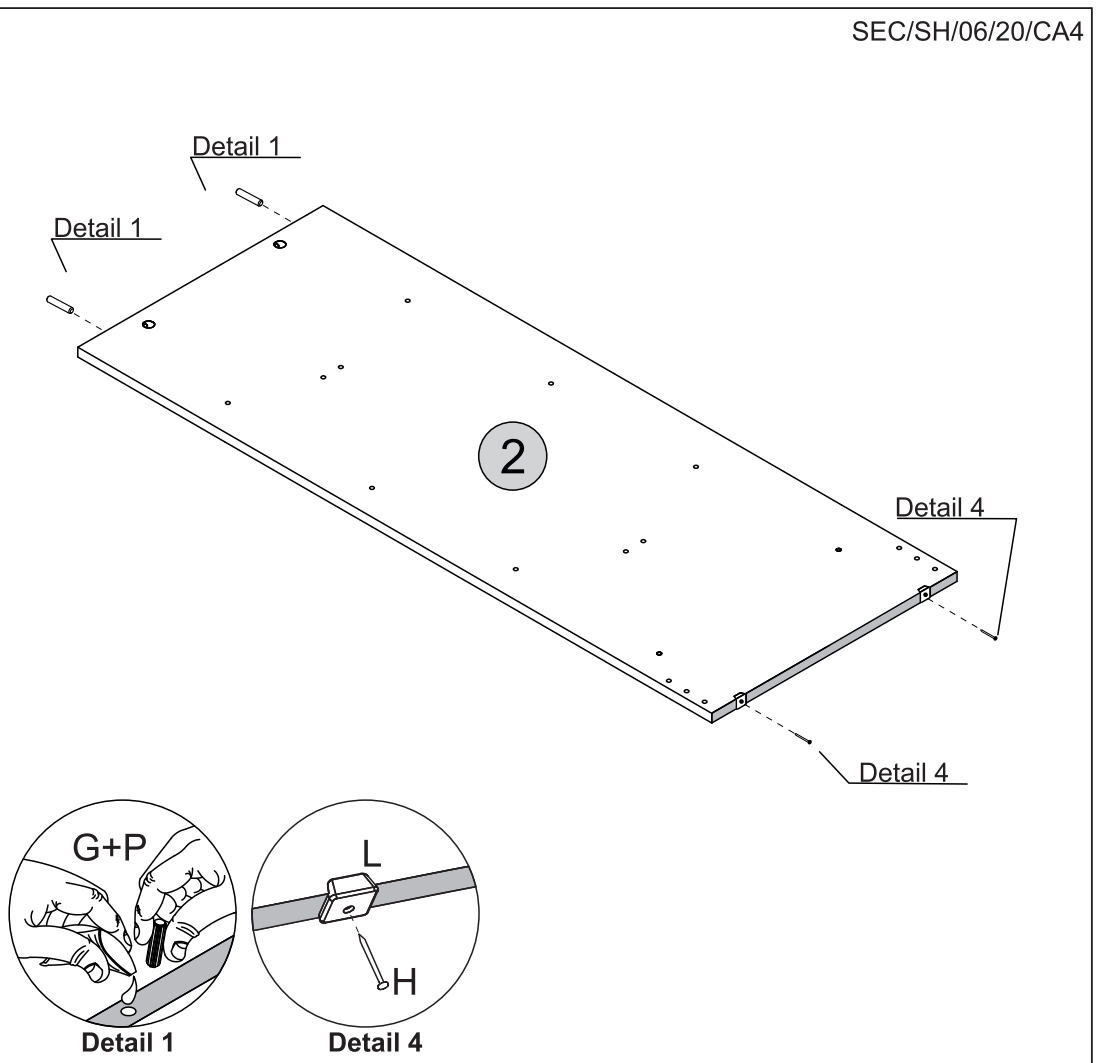
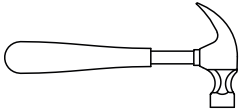



# STEP 2

## PARTS REQUIRED

1 - RIGHT SIDE PANEL x1

## HARDWARE REQUIRED

G  02  
Ø6 x 30

H  02  
10 x 10

L  02

P  01  
GLUE

## TOOLS REQUIRED

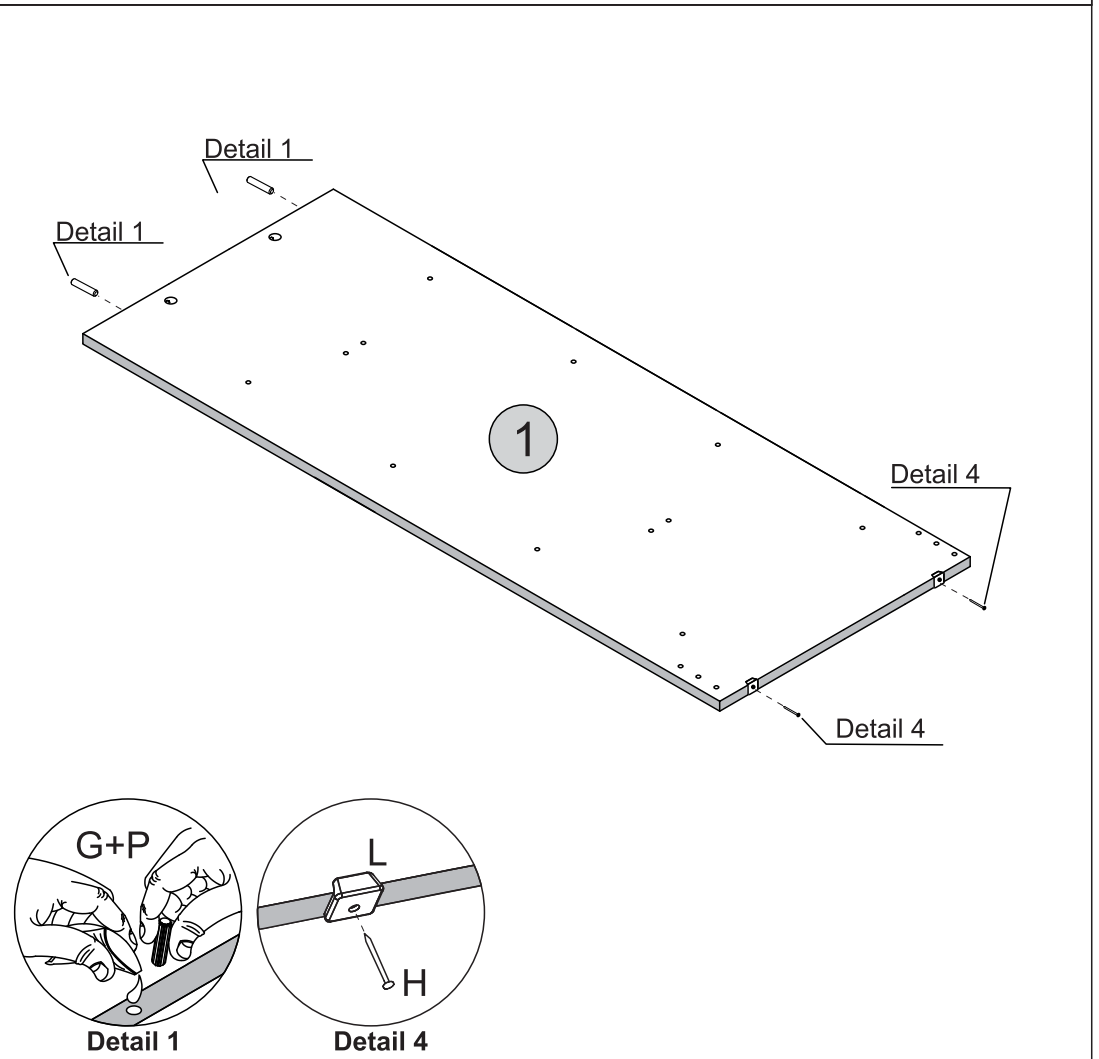
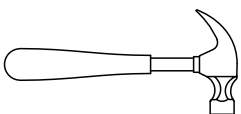

# STEP 3

## PARTS REQUIRED

2 - LEFT SIDE PANEL x1

## HARDWARE REQUIRED

A  08  
Ø6,0 x 8mm

Q  04  
LEFT

## TOOLS REQUIRED

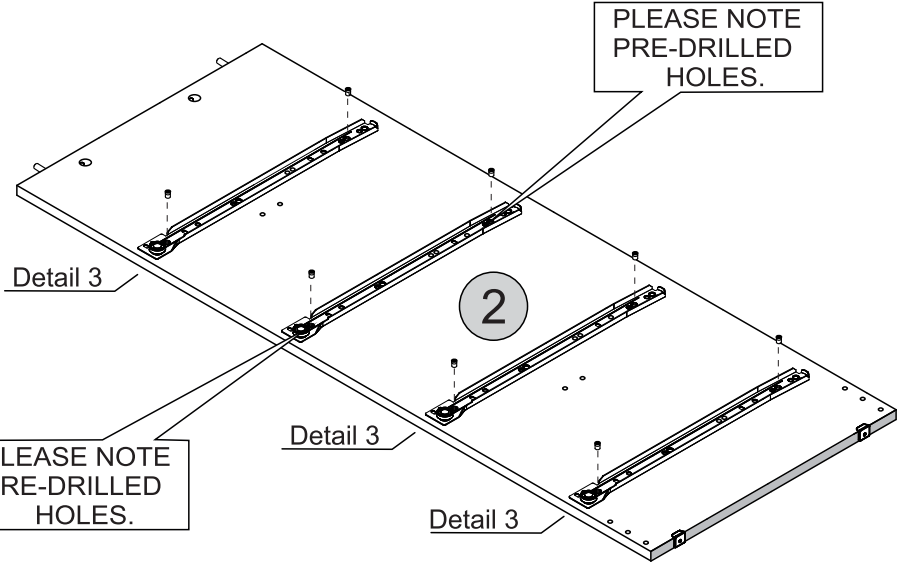
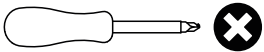

PLEASE NOTE  
PRE-DRILLED  
HOLES.

PLEASE NOTE  
PRE-DRILLED  
HOLES.

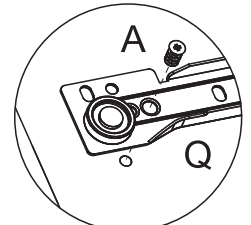
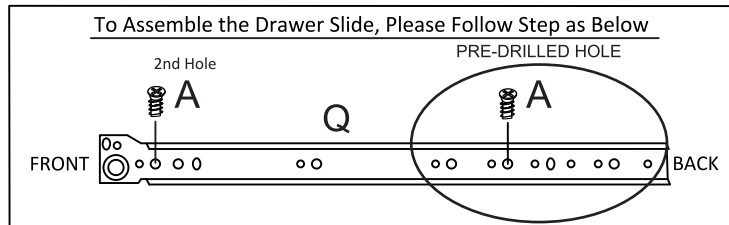

Detail 3

# STEP 4

## PARTS REQUIRED

1 - RIGHT SIDE PANEL x1

## HARDWARE REQUIRED

A  08  
Ø6,0 x 8mm

Q  04  
RIGHT

## TOOLS REQUIRED

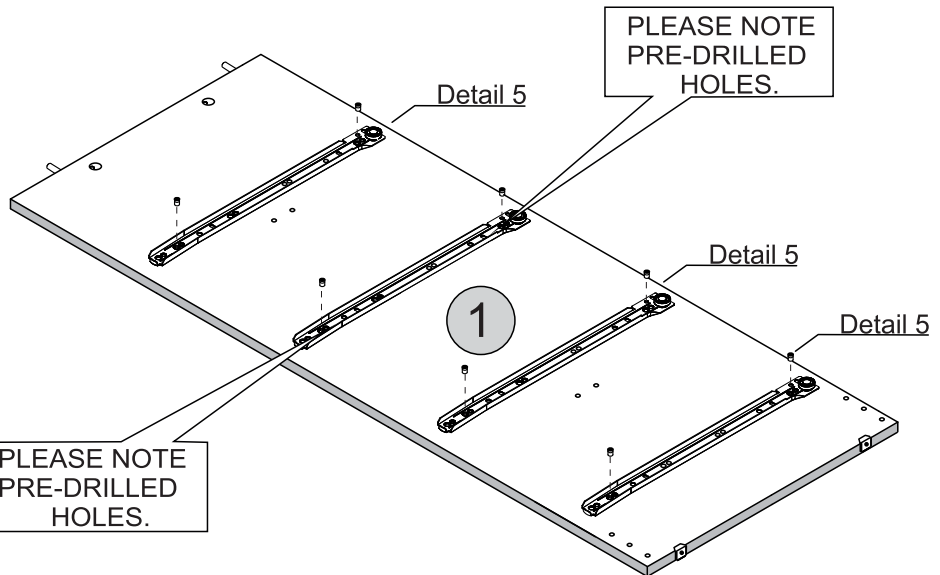
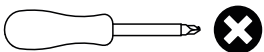

PLEASE NOTE  
PRE-DRILLED  
HOLES.

PLEASE NOTE  
PRE-DRILLED  
HOLES.

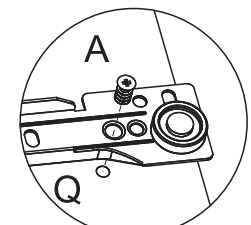
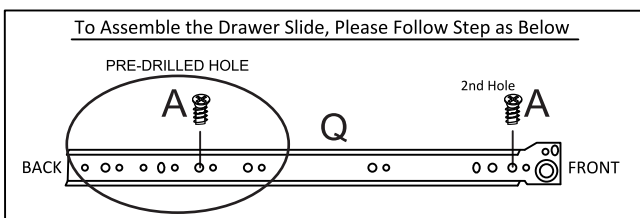



Detail 5

# STEP 5

## PARTS REQUIRED

3 - FRONT BASEBOARD	x1
4 - BACK BASEBOARD	x1
5 - CROSSBAR	x2

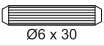
## HARDWARE REQUIRED

G		12
H		02
L		02
P	GLUE	01

## TOOLS REQUIRED

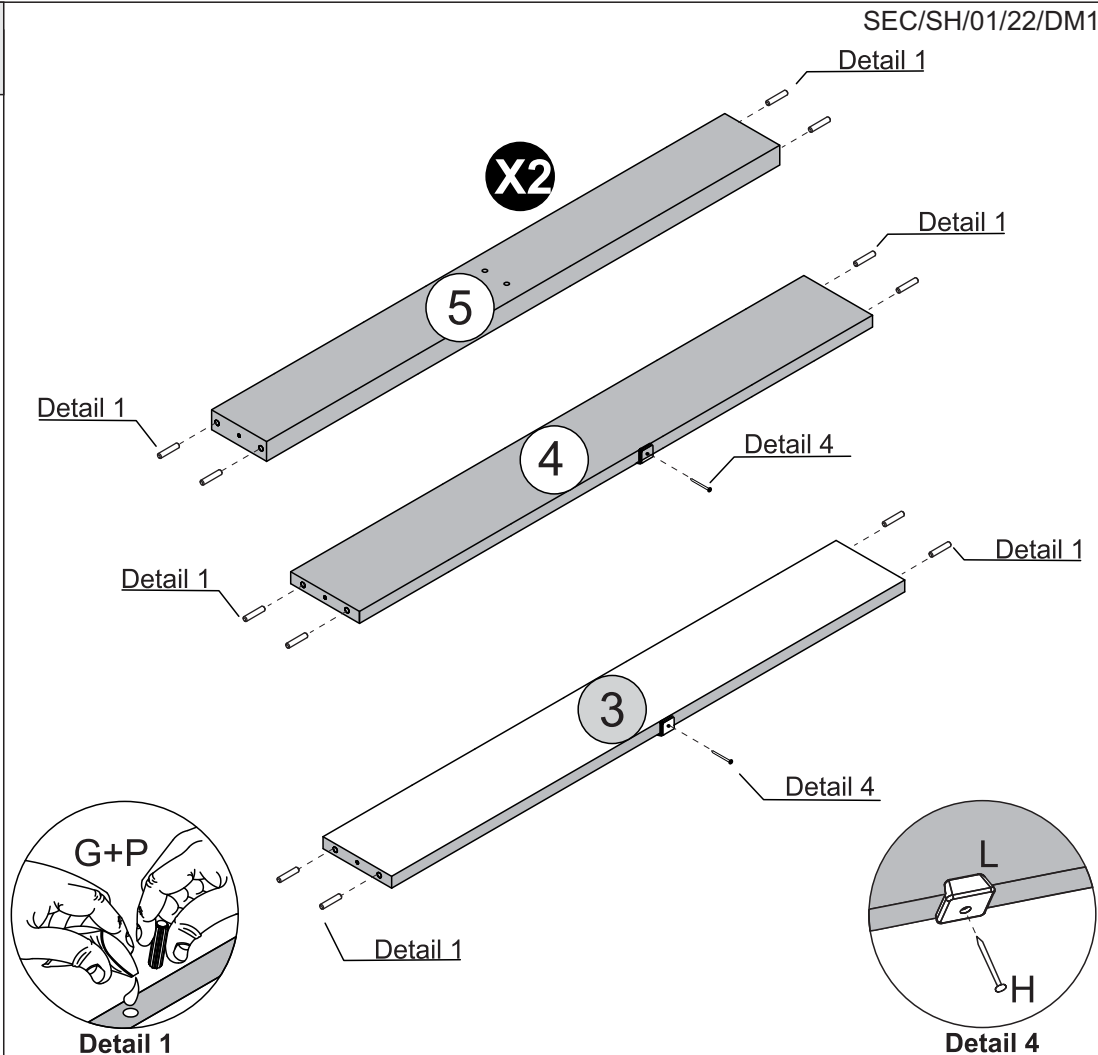
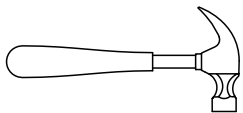



# STEP 6

## PARTS REQUIRED

7 - DIVISION PANEL	x1
--------------------	----

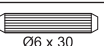
## HARDWARE REQUIRED

A		04
G		03
P	GLUE	01
Q	LEFT 	01
Q	RIGHT 	01

## TOOLS REQUIRED

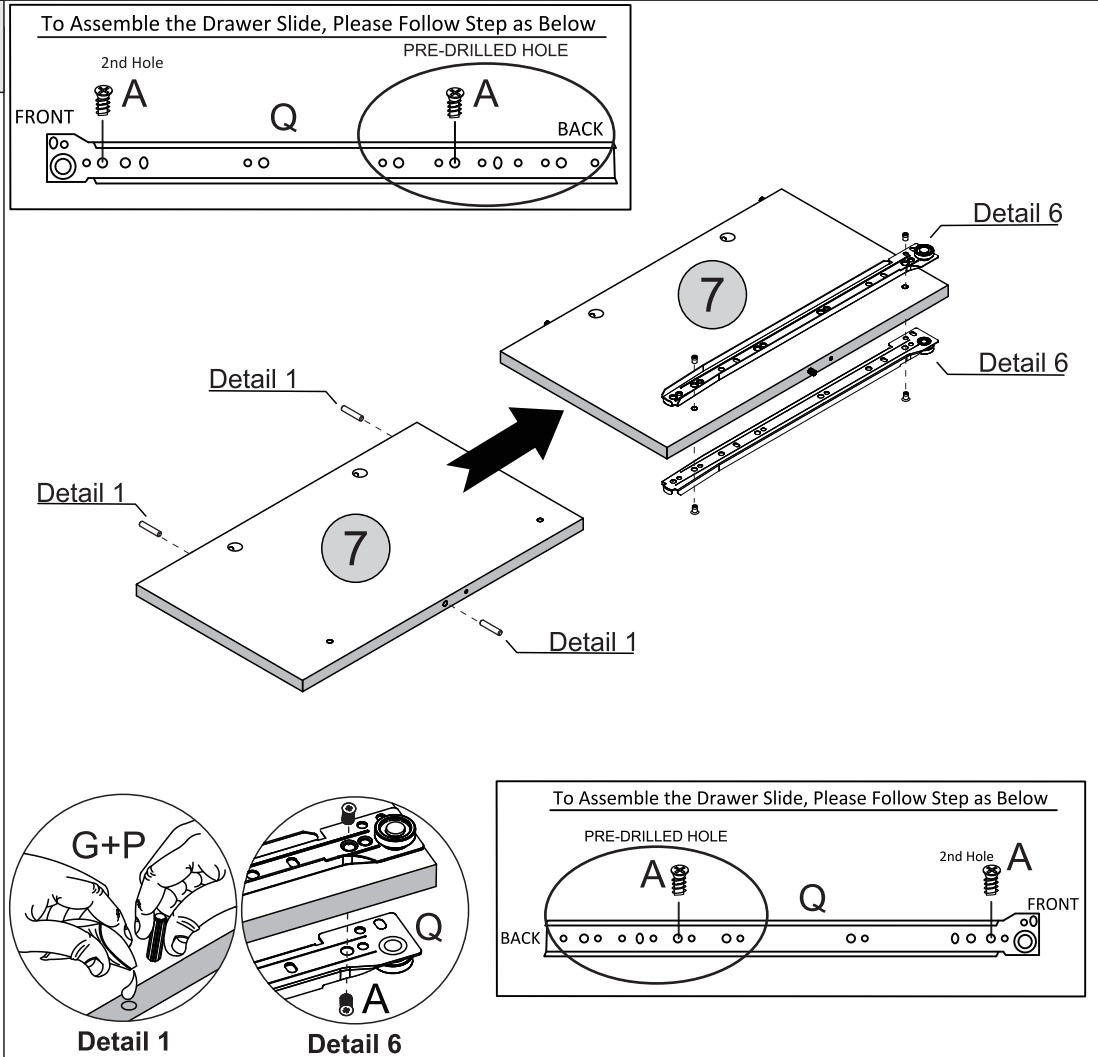
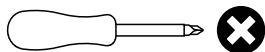

# STEP 7

## PARTS REQUIRED

1 - RIGHT SIDE PANEL	x1
3 - FRONT BASEBOARD	x1
4 - BACK BASEBOARD	x1
5 - CROSSBAR	x2

## HARDWARE REQUIRED

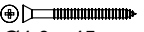
E		04
Ø4,0 x 45mm		

P		01
---	---	----

## TOOLS REQUIRED

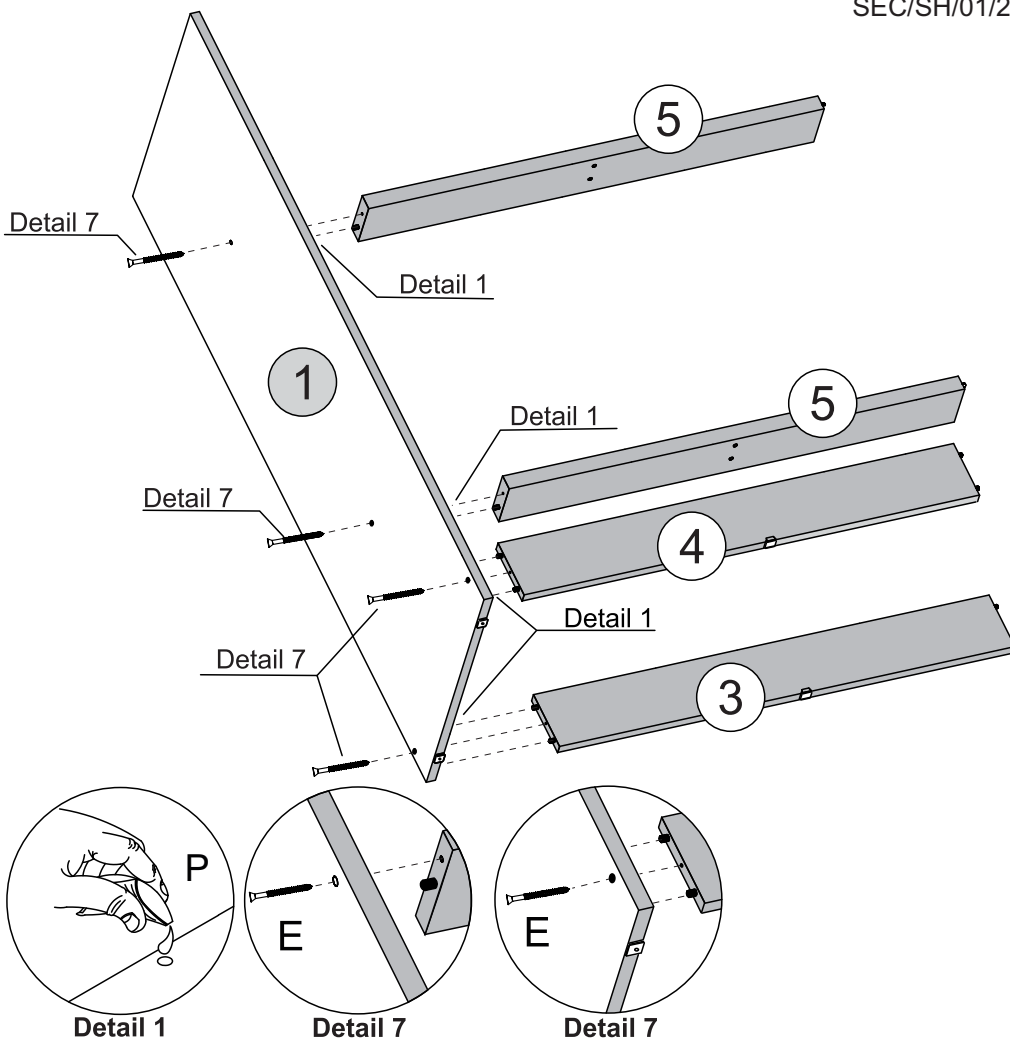
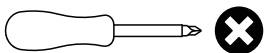

# STEP 8

## PARTS REQUIRED

2 - LEFT SIDE PANEL	x1
---------------------	----

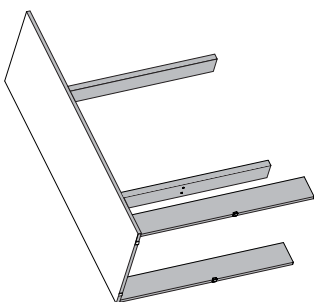

## HARDWARE REQUIRED

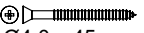
E		04
Ø4,0 x 45mm		

P		01
---	---	----

## TOOLS REQUIRED

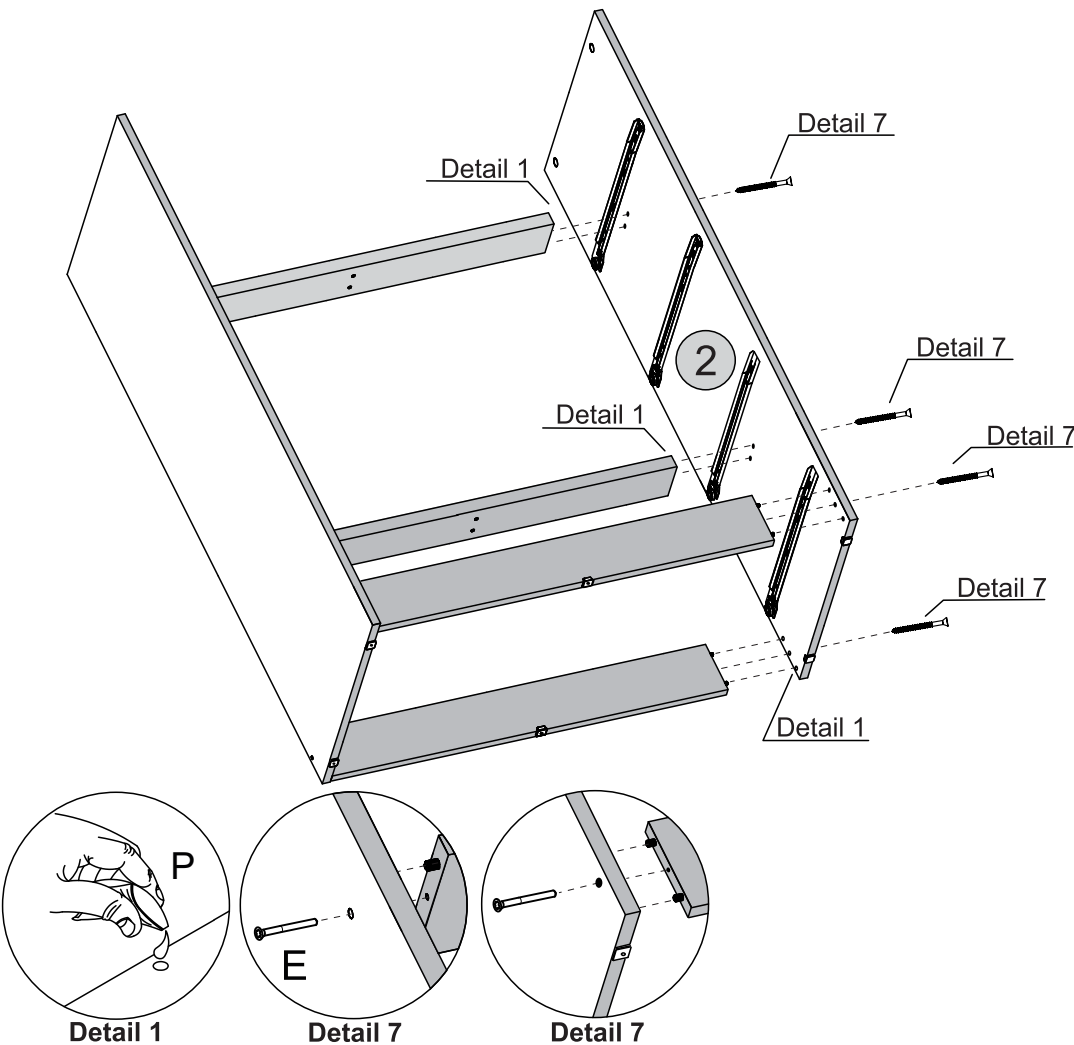
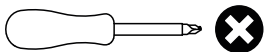

# STEP 9

## PARTS REQUIRED

6 - TOP PANEL x1

## HARDWARE REQUIRED

N  06

## TOOLS REQUIRED

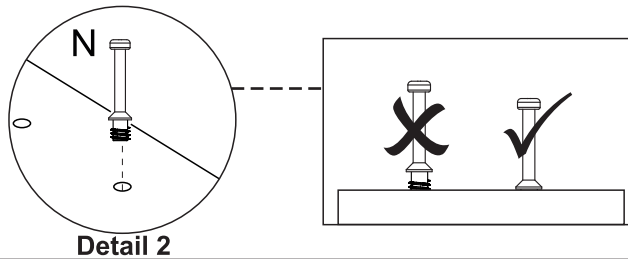
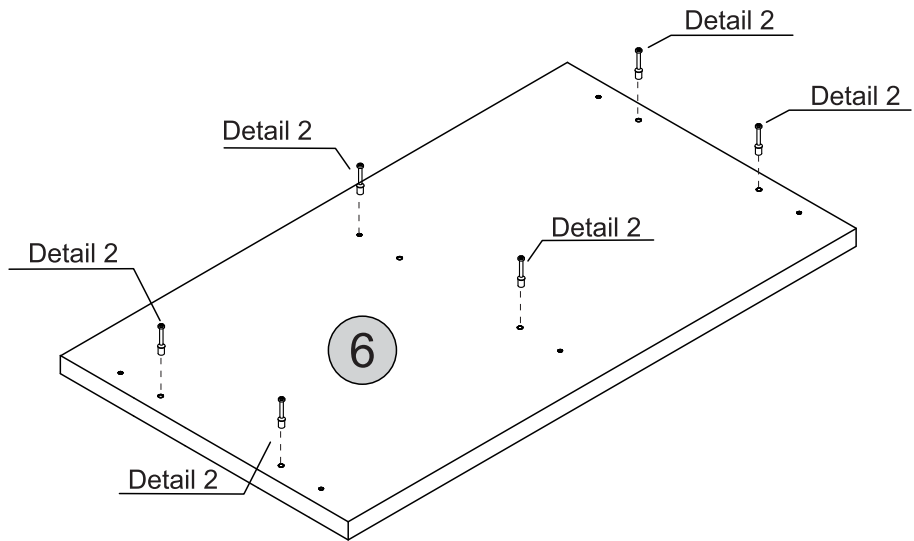
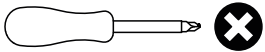

# STEP 10

## PARTS REQUIRED

6 - TOP PANEL x1

7 - DIVISION PANEL x1

## HARDWARE REQUIRED

J  02

P  01

## TOOLS REQUIRED

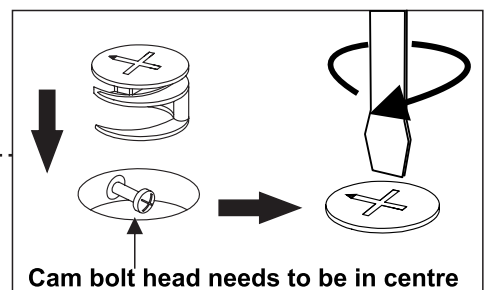
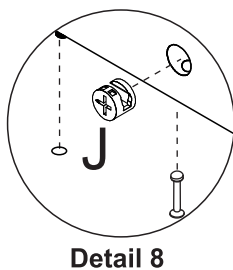
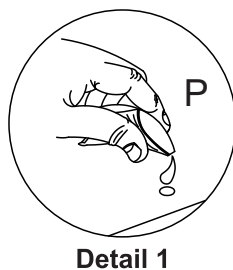
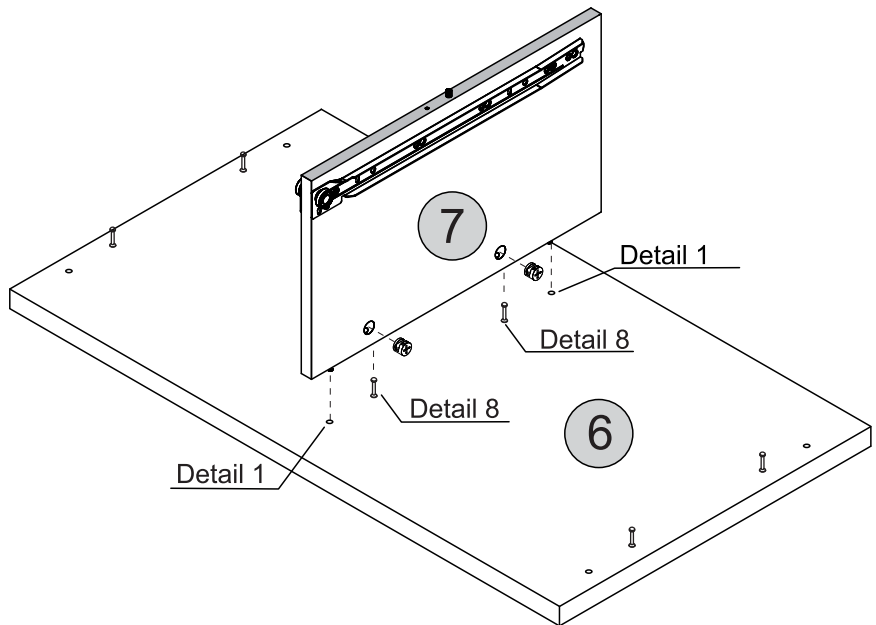
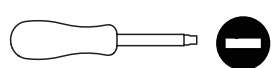



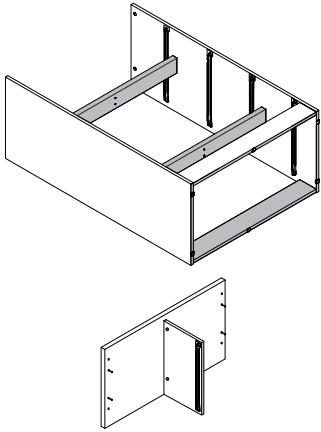

# STEP 11

## PARTS REQUIRED

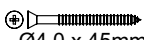

## HARDWARE REQUIRED

E	 Ø4.0 x 45mm	01
P	 GLUE	01
J		04

## TOOLS REQUIRED

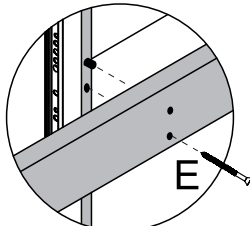
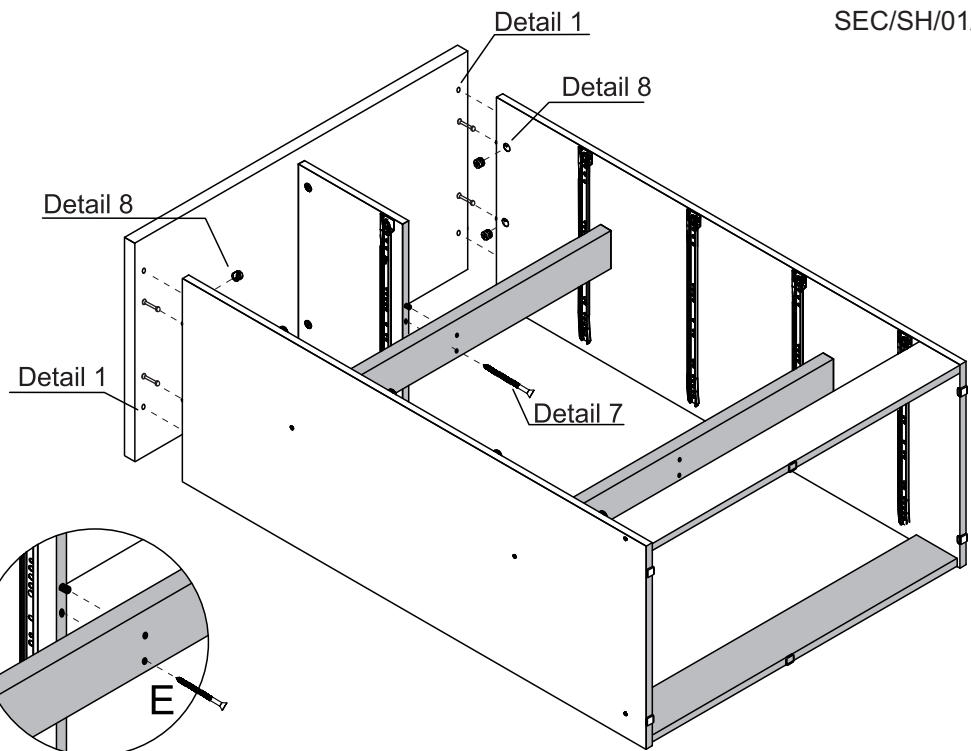
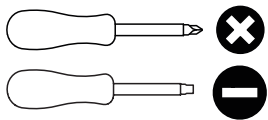

Detail 7



Detail 1

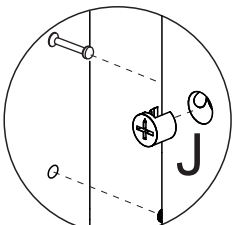

Detail 8

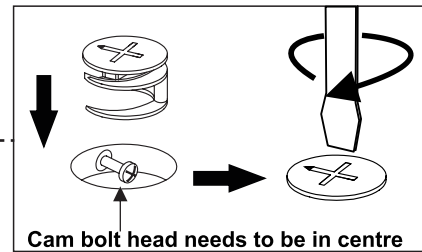



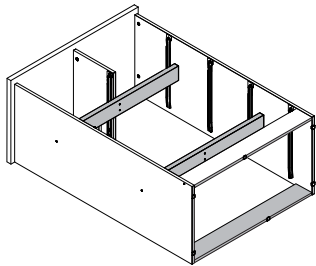

# STEP 12

## PARTS REQUIRED

8 - BACK PANEL	x2
----------------	----



## HARDWARE REQUIRED

B	 Ø3,5 x 12mm	06
H	 10 x 10	30
I		02
R		01

## TOOLS REQUIRED

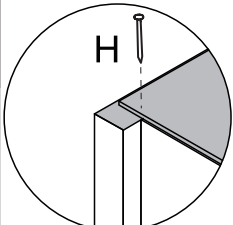
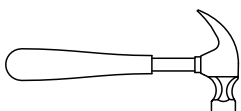

Detail 10

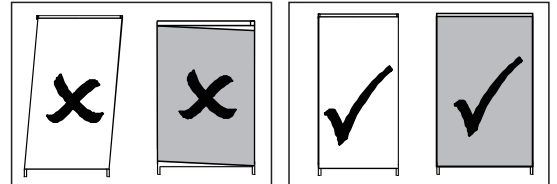

\* For your future reference  
Order Number should be here

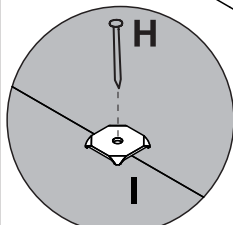
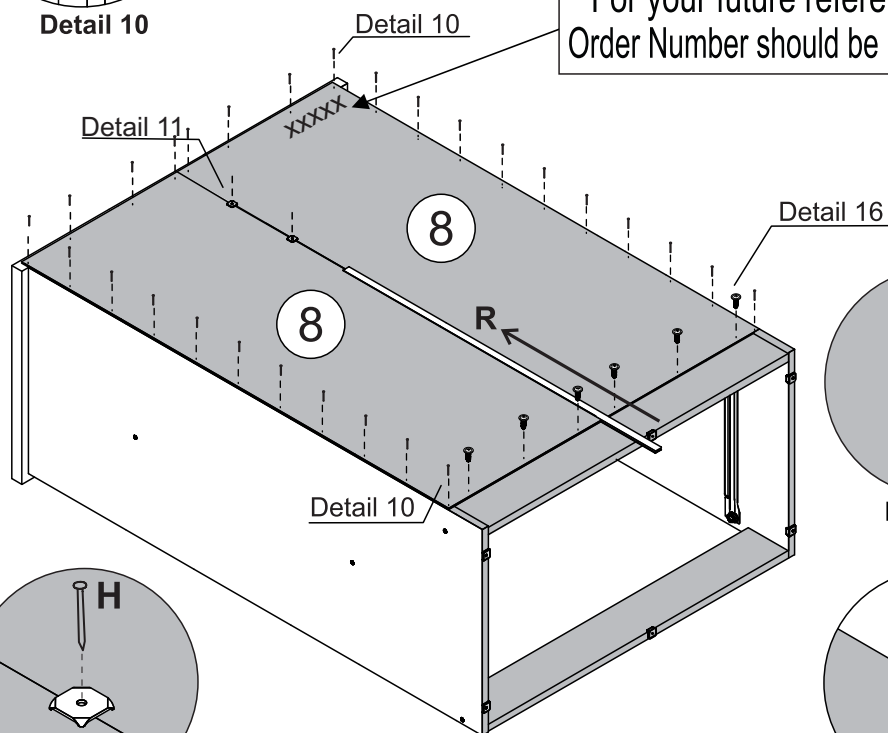

Detail 11

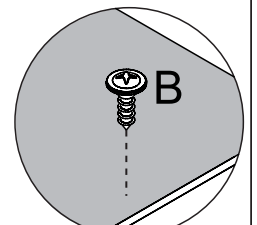

Detail 16

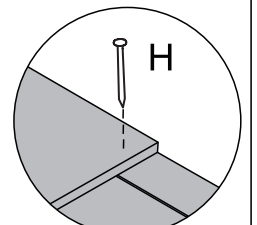

Detail 10

# STEP 13

## PARTS REQUIRED

9 - DRAWER SIDE x10

10 - LARGE DRAWER BACK PANEL x3

13 - DRAWER BOTTOM SUPPORT BAR x3

14 - SMALL DRAWER BACK PANEL x2

## HARDWARE REQUIRED

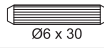
G  46  
Ø6 x 30

P  01  
GLUE

## TOOLS REQUIRED

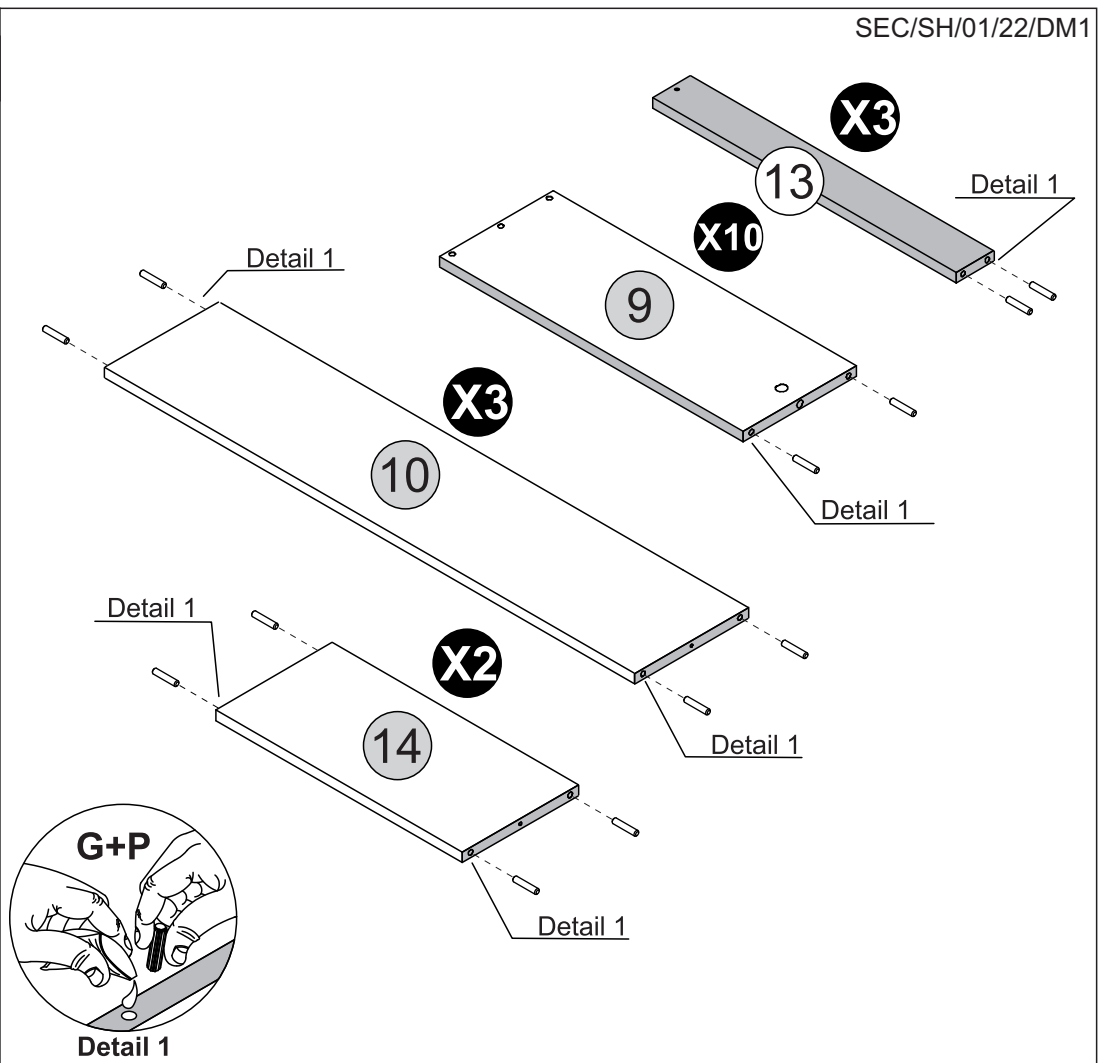

# STEP 14

## PARTS REQUIRED

11 - LARGE DRAWER FRONT x3

15 - SMALL DRAWER FRONT x2

## HARDWARE REQUIRED

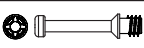
N  10

## TOOLS REQUIRED

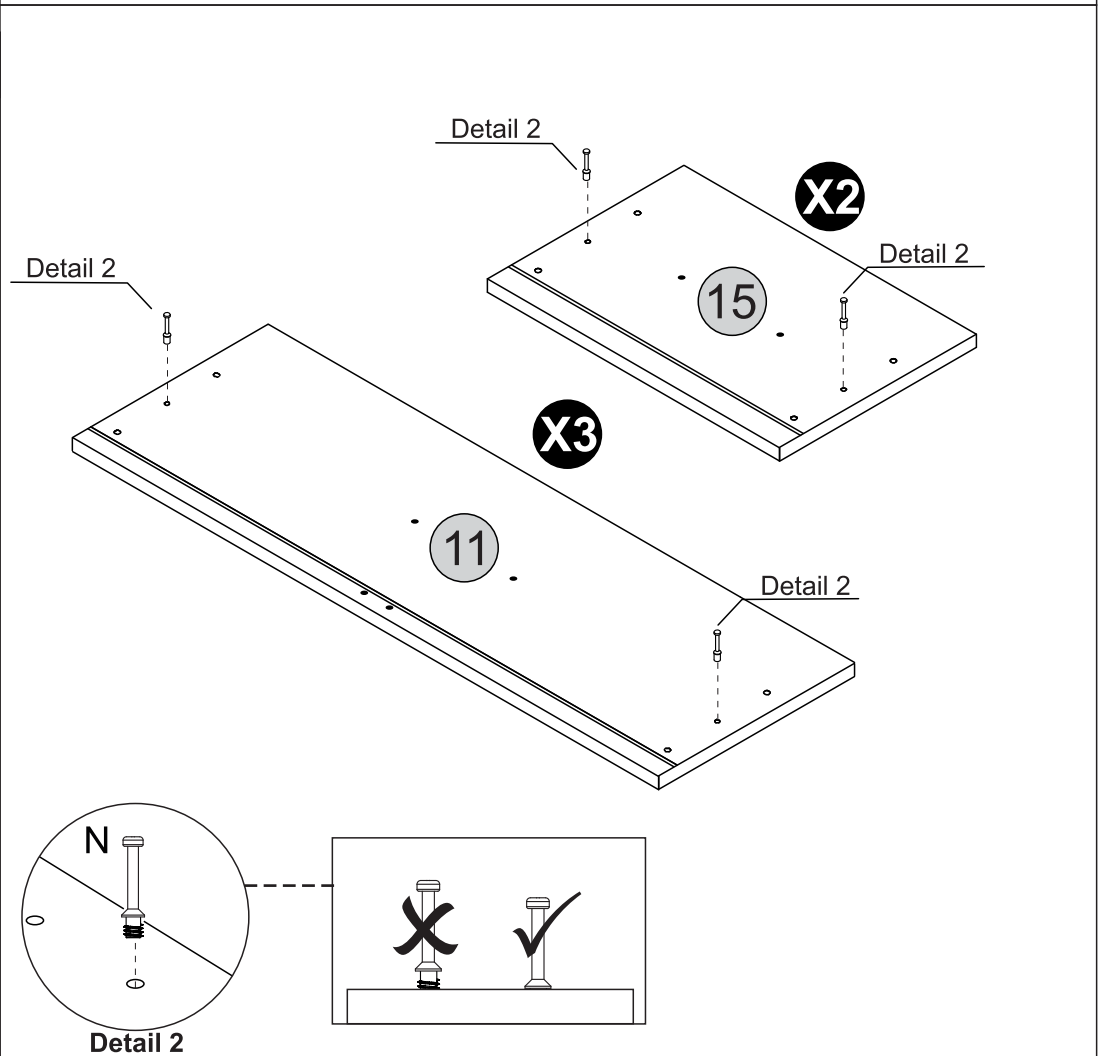
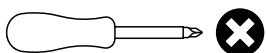

# STEP 15

**PARTS REQUIRED**

9 - DRAWER SIDE x6

10 - LARGE DRAWER BACK PANEL x3

**HARDWARE REQUIRED**

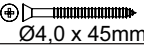
E  06  
Ø4.0 x 45mm

**TOOLS REQUIRED**

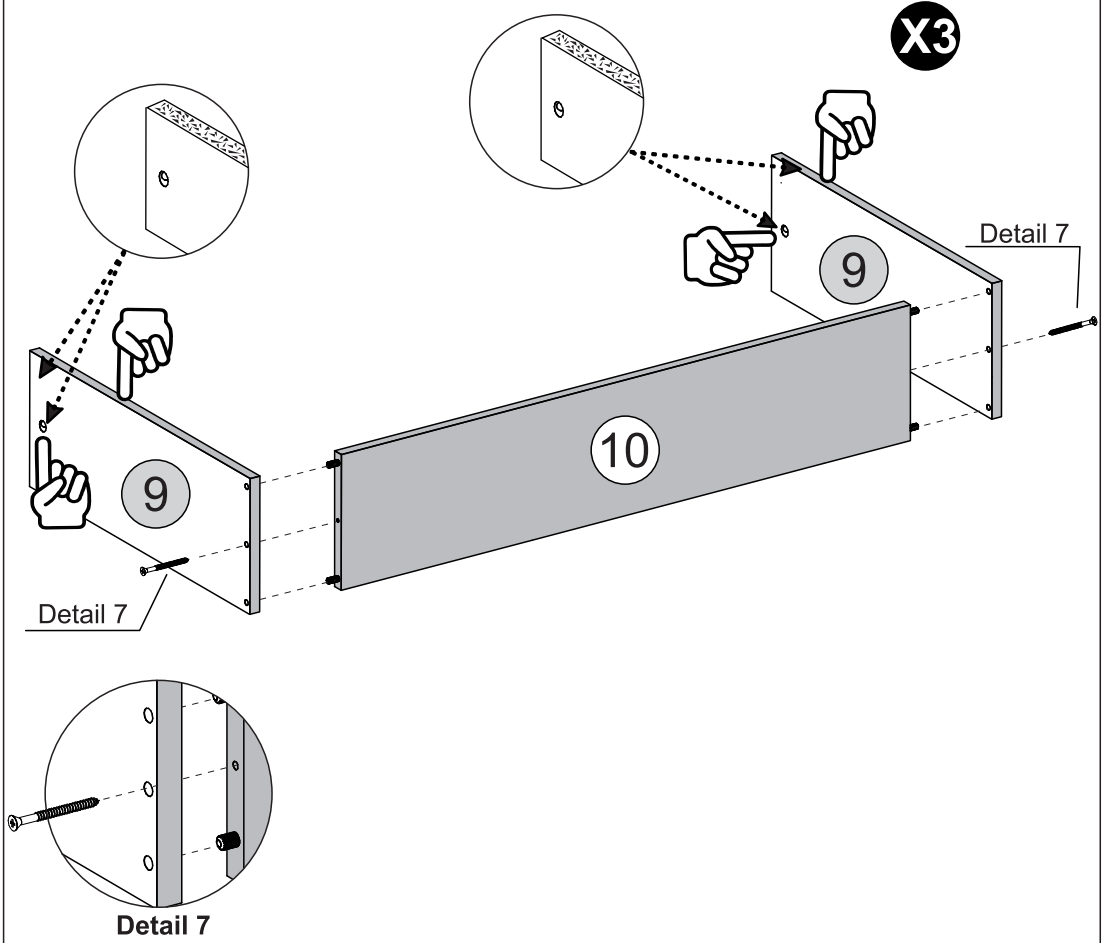
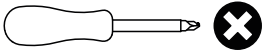

# STEP 16

**PARTS REQUIRED**

11 - LARGE DRAWER FRONT x3

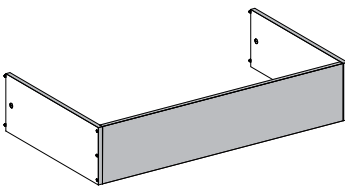

**HARDWARE REQUIRED**

P  01

**TOOLS REQUIRED**

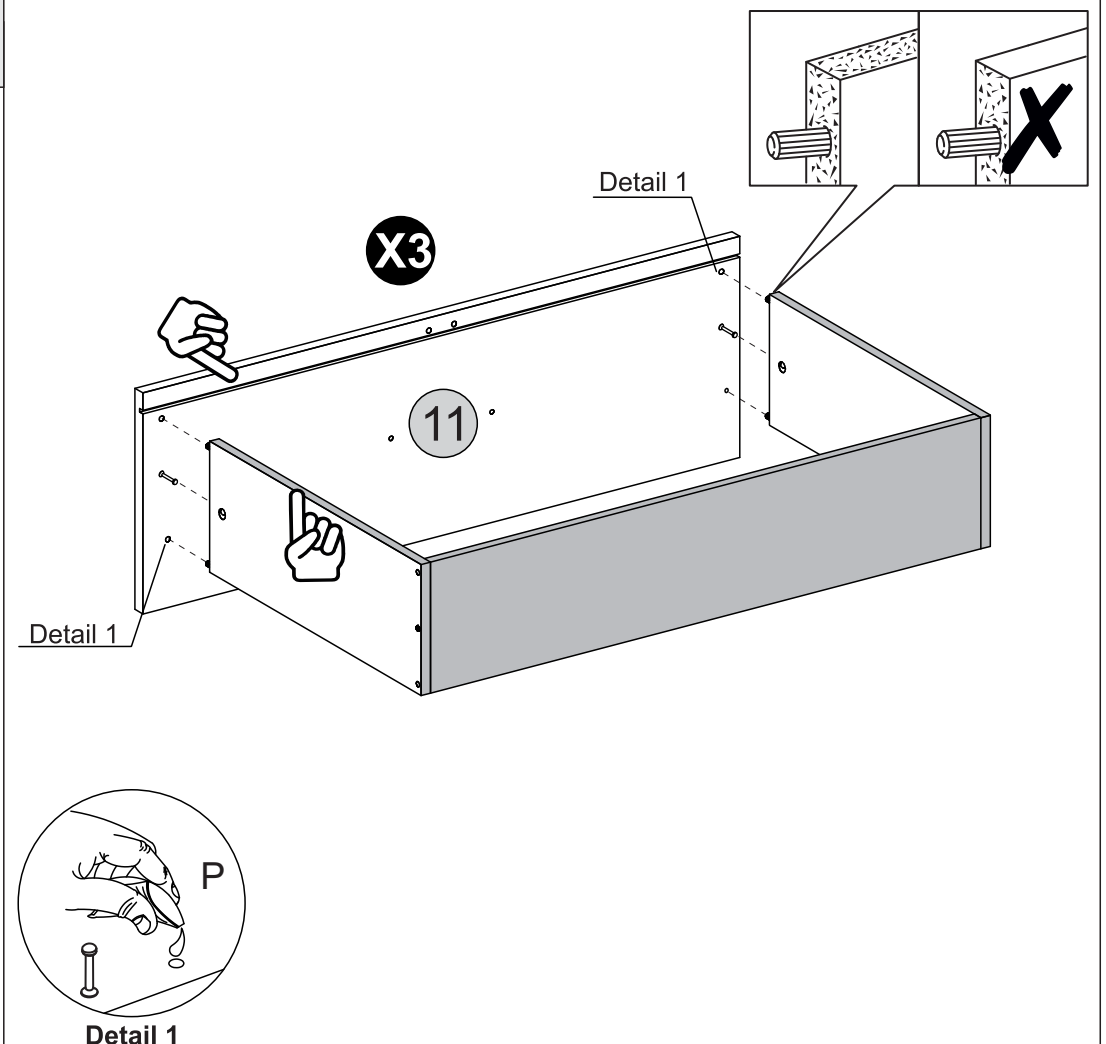
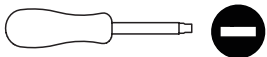

# STEP 17

**PARTS REQUIRED**

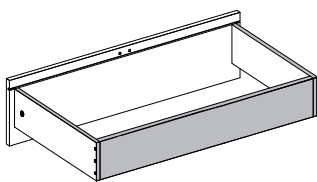

**HARDWARE REQUIRED**



**TOOLS REQUIRED**

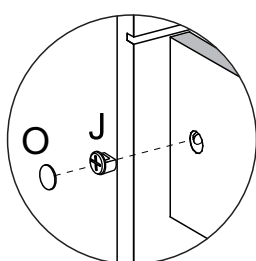
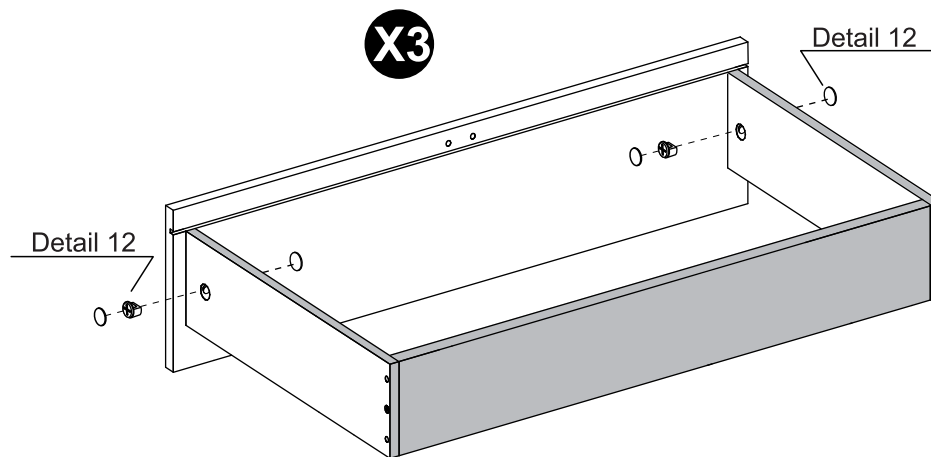
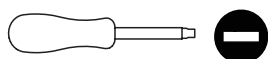

Detail 12

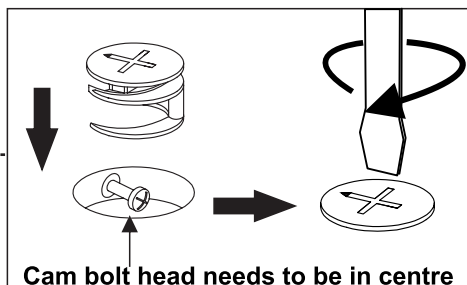

Cam bolt head needs to be in centre

# STEP 18

**PARTS REQUIRED**

12 - LARGE DRAWER BOTTOM x3

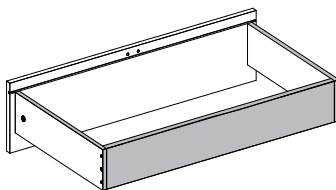

**HARDWARE REQUIRED**

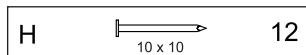

**TOOLS REQUIRED**

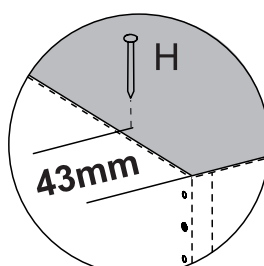
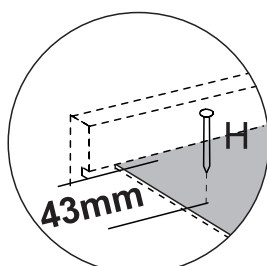
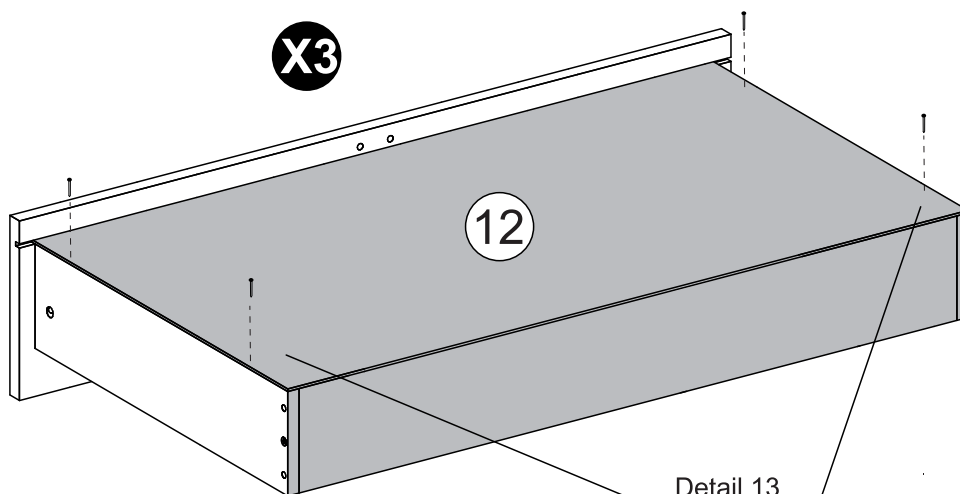
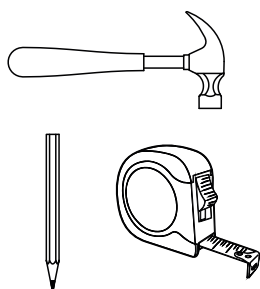

Detail 13

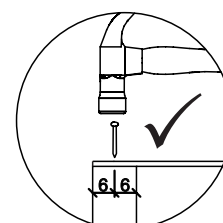
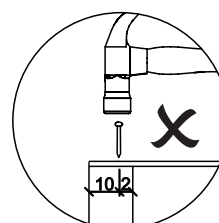
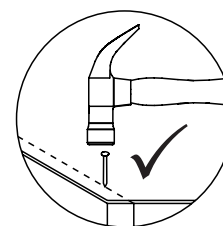
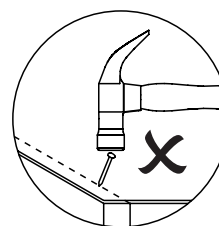

# STEP 19

## PARTS REQUIRED

13 - DRAWER BOTTOM SUPPORT BAR X3

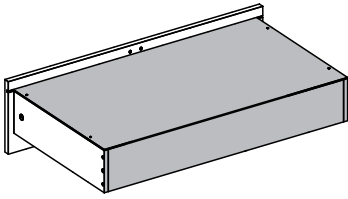

## HARDWARE REQUIRED

H  18

P  01

## TOOLS REQUIRED

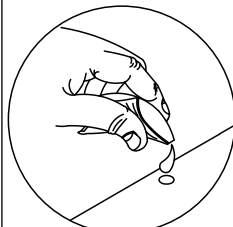
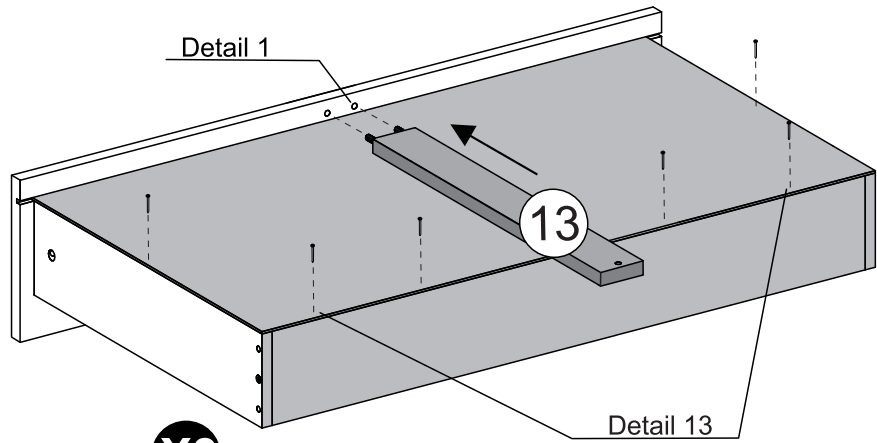
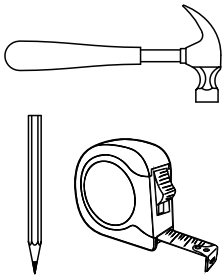

Detail 1

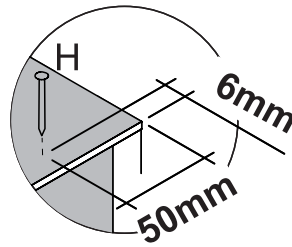

Detail 13

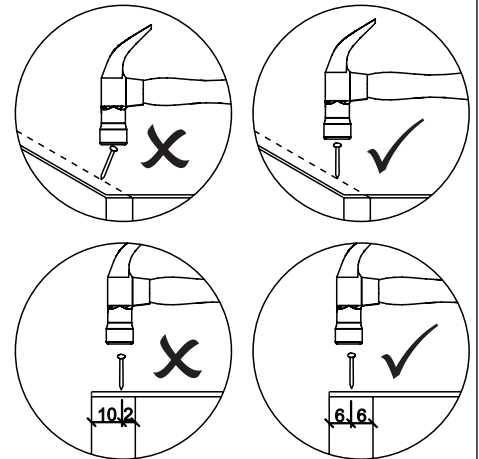

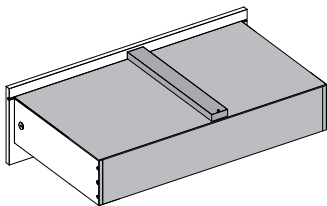

# STEP 20

## PARTS REQUIRED



## HARDWARE REQUIRED

C  12  
Ø4,0 x 14mm

T  03  
Ø3,5 x 25mm

Q  03  
LEFT

Q  03  
RIGHT

## TOOLS REQUIRED

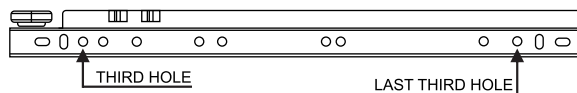
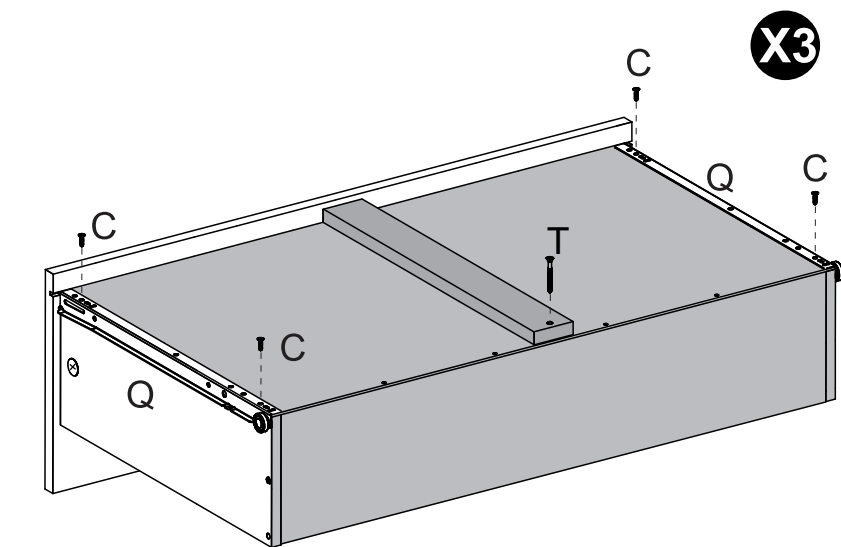
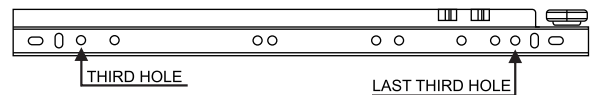
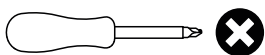

# STEP 21

**PARTS REQUIRED**

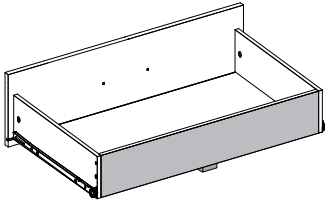

**HARDWARE REQUIRED**

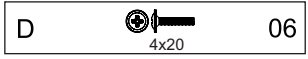

**TOOLS REQUIRED**

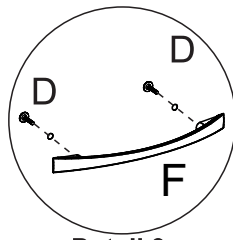
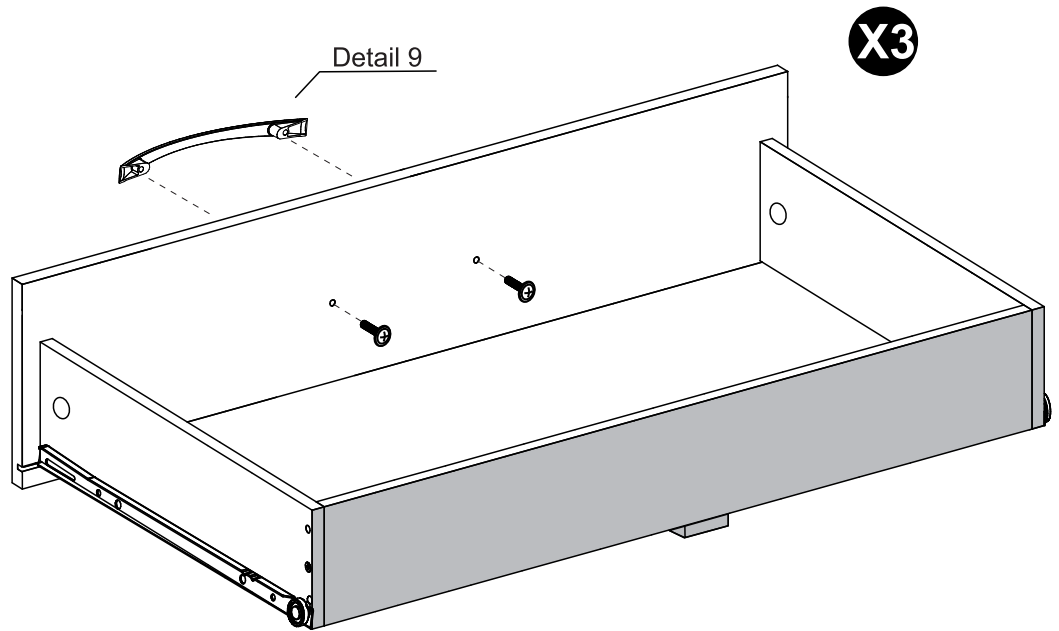
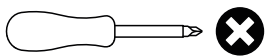

Detail 9

# STEP 22

**PARTS REQUIRED**



**HARDWARE REQUIRED**

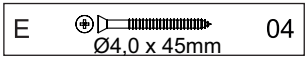

**TOOLS REQUIRED**

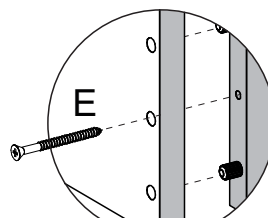
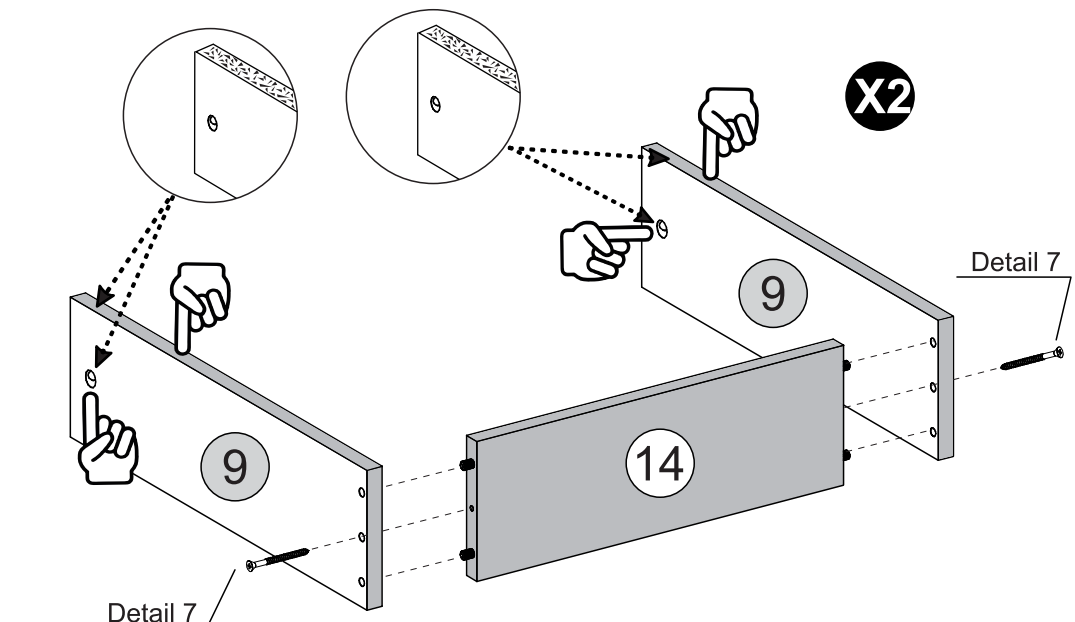
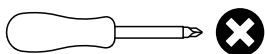

Detail 7

# STEP 23

## PARTS REQUIRED

15 - SMALL DRAWER FRONT x3

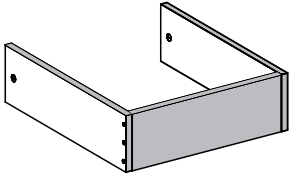

## HARDWARE REQUIRED

P  01

## TOOLS REQUIRED

**X2**

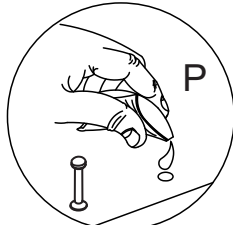
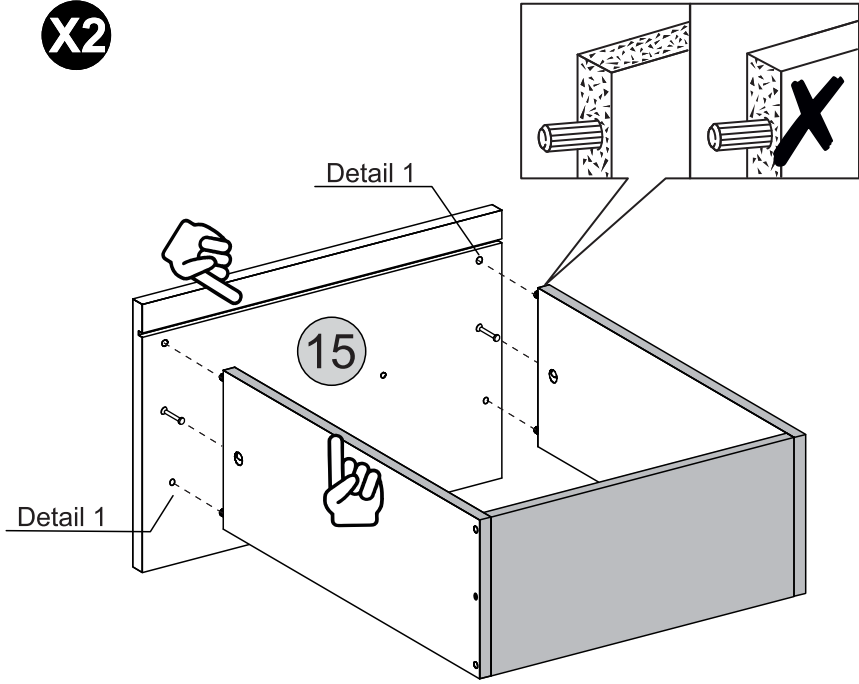

Detail 1

# STEP 24

## PARTS REQUIRED

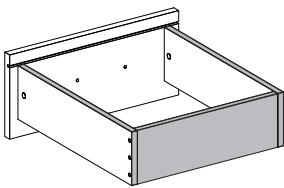

## HARDWARE REQUIRED

J  04

O  08

## TOOLS REQUIRED

**X2**

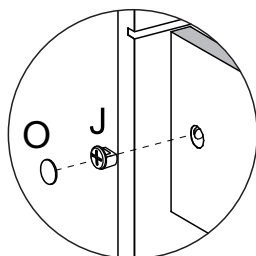
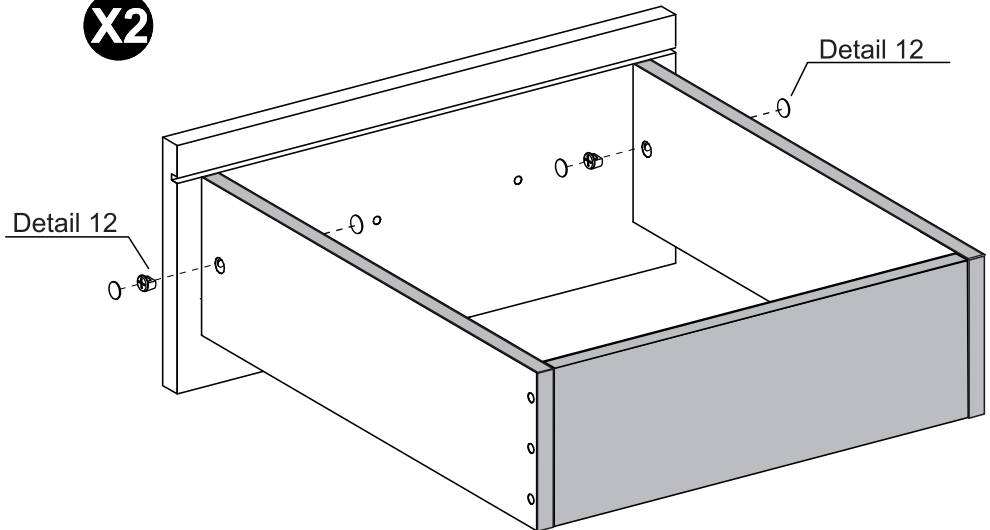

Detail 12

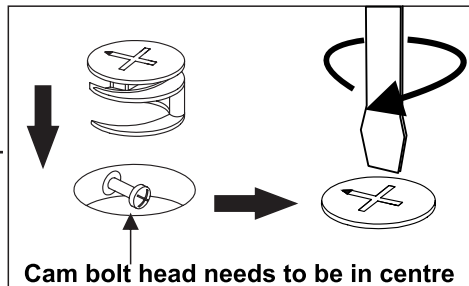

Cam bolt head needs to be in centre

# STEP 25

**PARTS REQUIRED**

16 - DRAWER BOTTOM x2

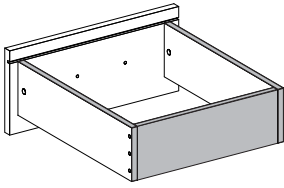

**HARDWARE REQUIRED**

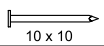
H  08

**TOOLS REQUIRED**

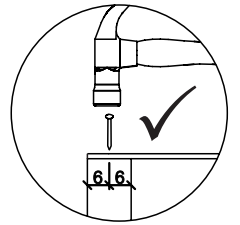
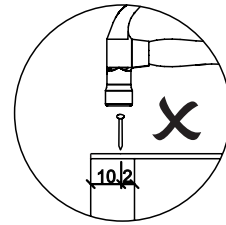
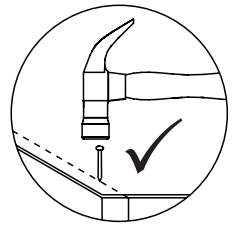
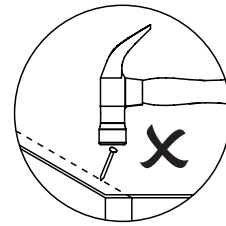
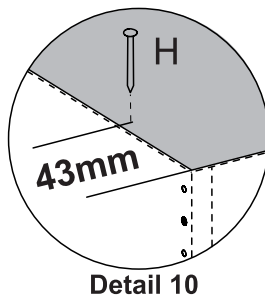
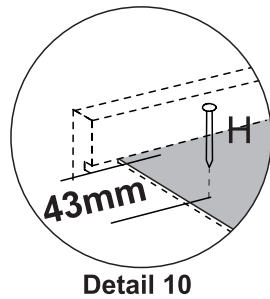
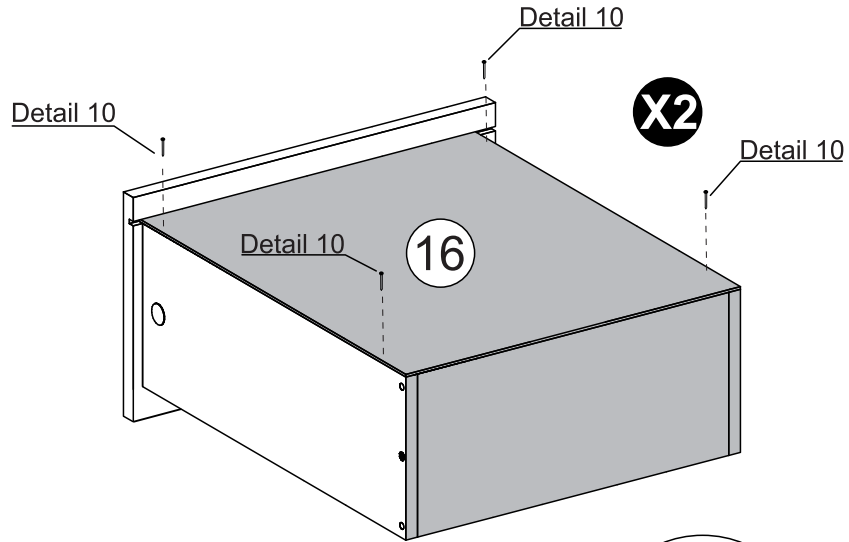
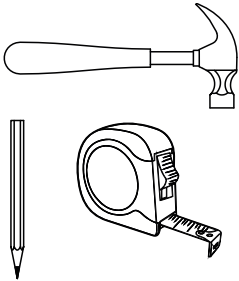

# STEP 26

**PARTS REQUIRED**

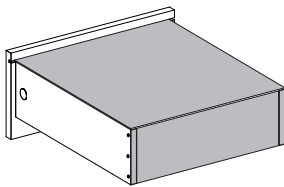

**HARDWARE REQUIRED**

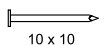
H  08

**TOOLS REQUIRED**

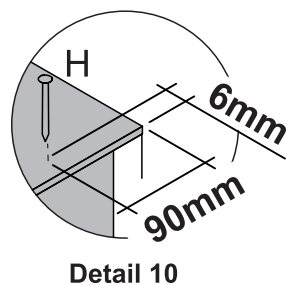
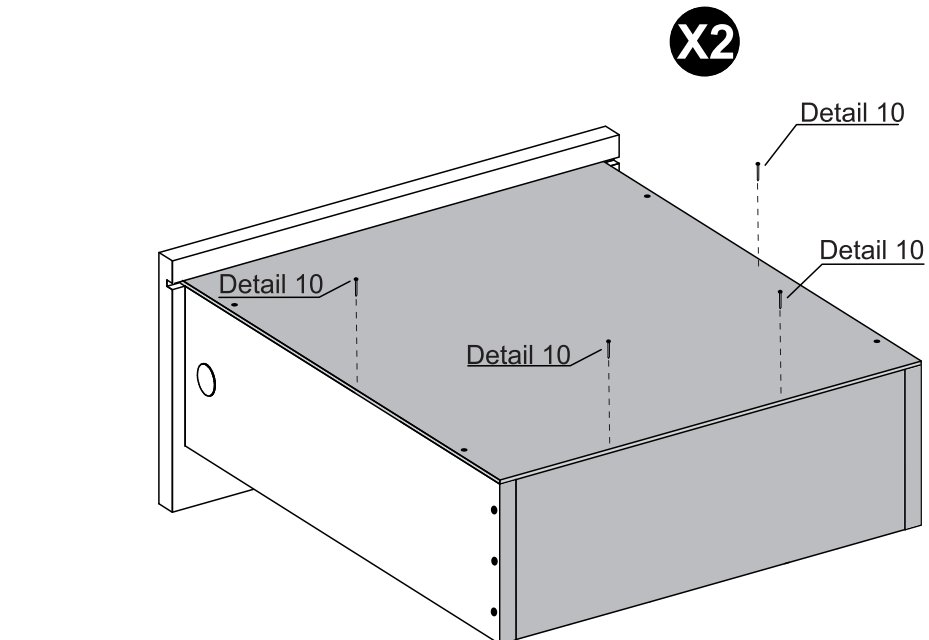
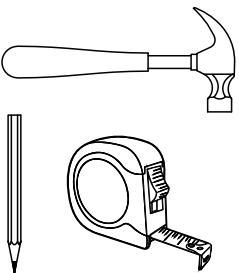



# STEP 27

**PARTS REQUIRED**

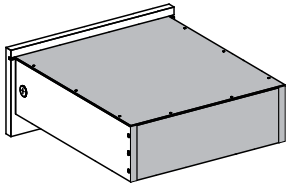

**HARDWARE REQUIRED**

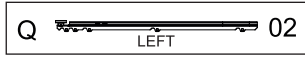
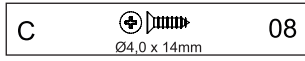

**TOOLS REQUIRED**

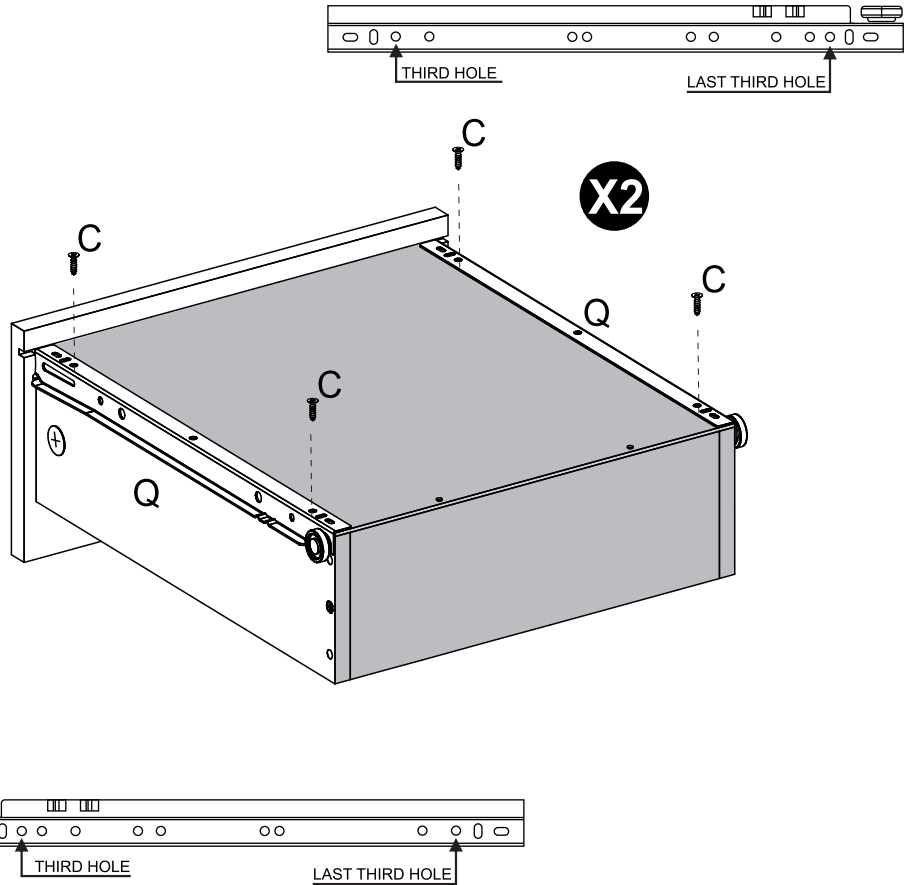
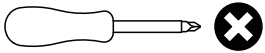

# STEP 28

**PARTS REQUIRED**

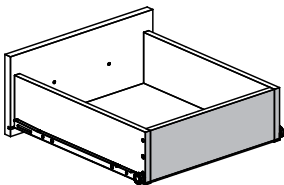

**HARDWARE REQUIRED**

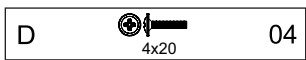

**TOOLS REQUIRED**

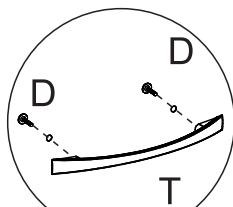
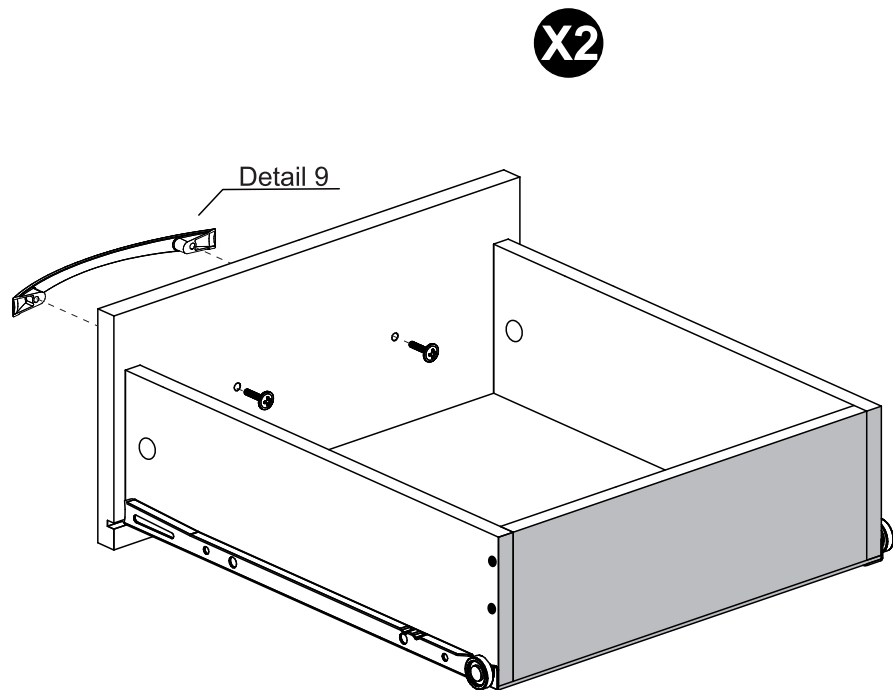
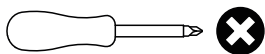

Detail 9

# STEP 29

**PARTS REQUIRED**

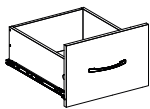
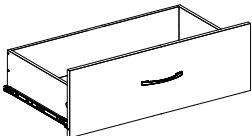
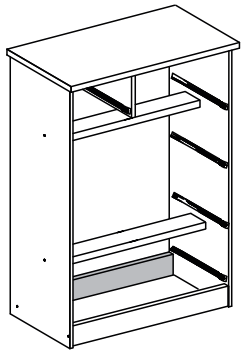

**HARDWARE REQUIRED**



**TOOLS REQUIRED**

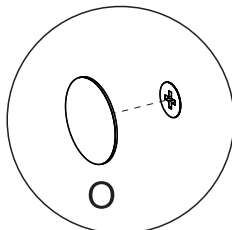
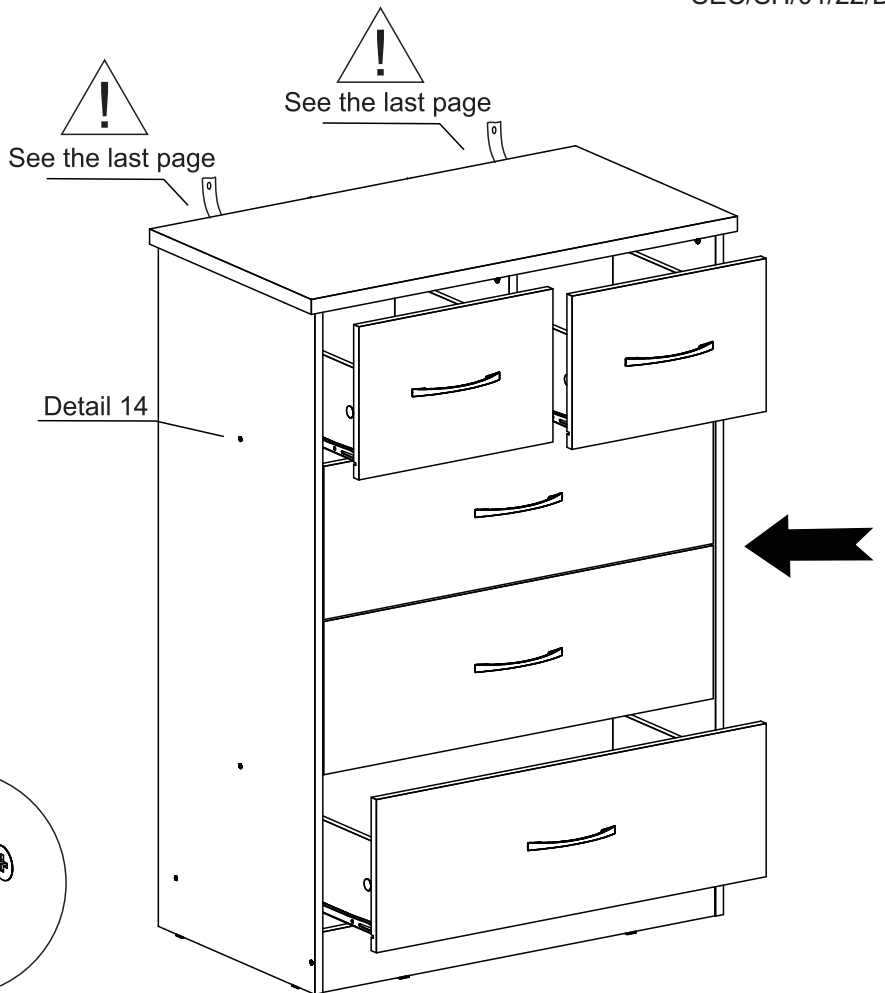

Detail 14

# STEP 30

**PARTS REQUIRED**

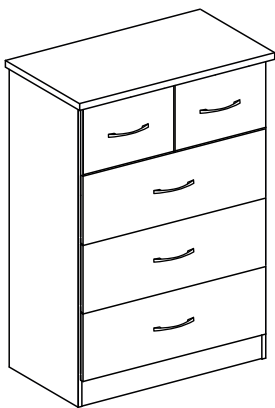

**HARDWARE REQUIRED**

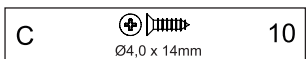

**TOOLS REQUIRED**

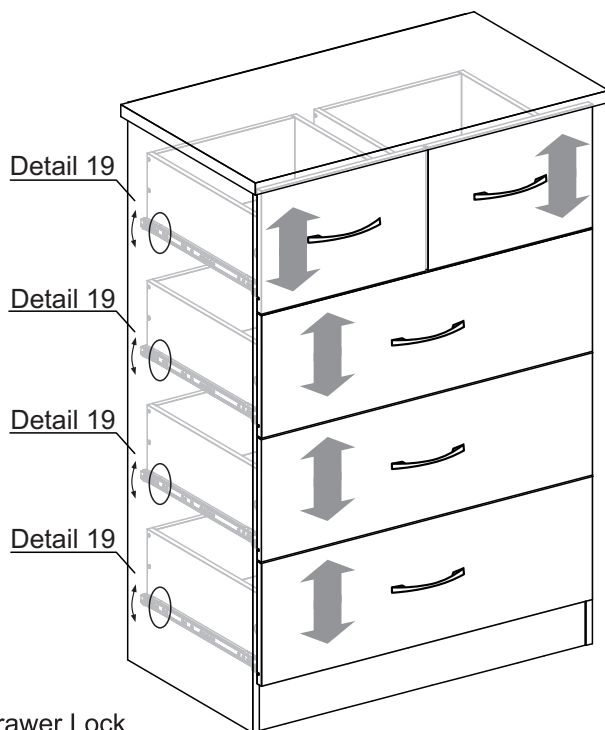

**TIP**  
If desired, after assembly use an alcohol cleaner to erase the number printed on the parts.

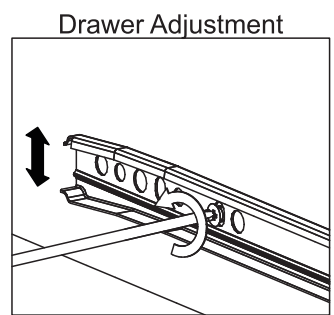

Detail 19

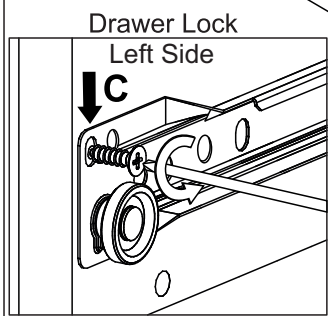

Detail 18

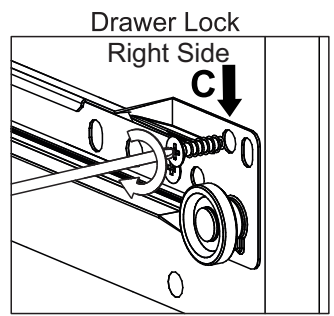

Detail 15

## WARNING

**Serious or fatal injuries can occur from furniture tipping over. To prevent the furniture from tipping over we recommend that it is permanently fixed to the wall.**

Wall fixings are not supplied with this product as different wall materials require different types of fixing devices.

Please make sure you use fixings suitable for the walls in your home.

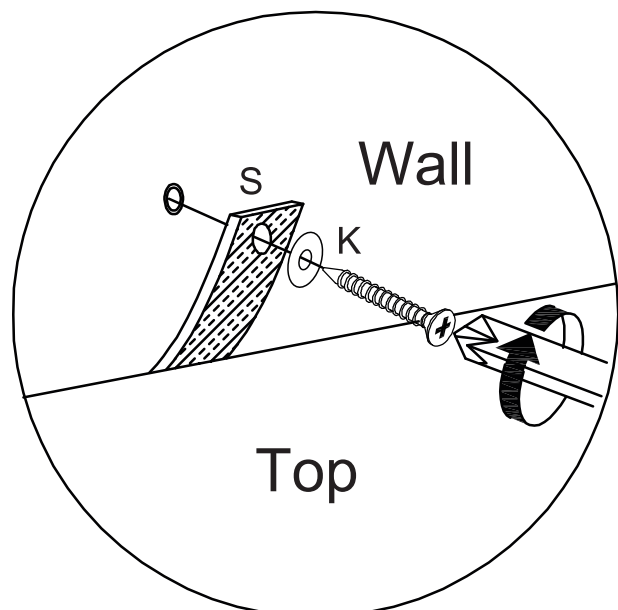
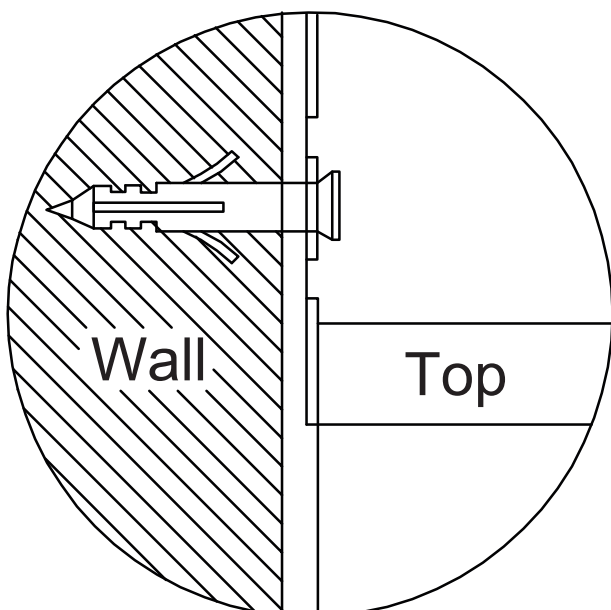
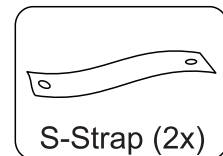
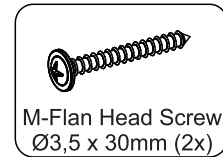
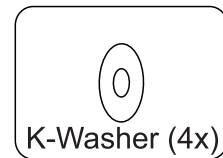
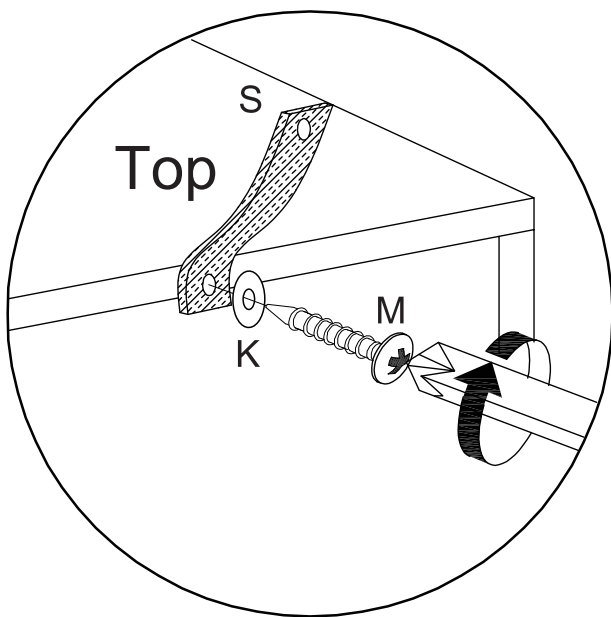

# NEVADA 3 DRAWER BEDSIDE BLACK WOOD GRAIN ASSEMBLY INSTRUCTIONS

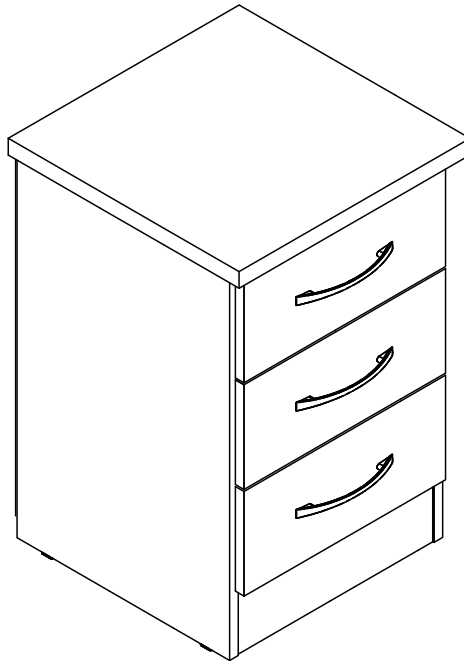

## IMPORTANT FOR DOMESTIC USE ONLY

PLEASE READ BEFORE YOU CONTINUE FURTHER

## CARE AND MAINTENANCE

After unpacking this product please keep the original packaging in case it needs to be returned for any reason.

- Please ensure all fittings and parts are present before commencing with assembly.
- Never drag or push products as this could cause damage to the joints making it inferior.
- We strongly recommend that you keep children away from your work area.
- We recommend that you lay a blanket or sheet on the floor to avoid damage to both your floor and the product.
- Assemble this product as close to its final position as possible.
- Do not place this product next to a radiator or in direct sunlight.
- Do not drag or push items across your high gloss furniture as this may cause the surface to scratch
- Wood is a natural product and may expand if subjected to damp and may shrink or crack if subjected to heat. Therefore it is recommended that room temperature is maintained, with no sudden temperature fluctuations.
- Make sure any spillage is wiped off immediately.
- Do not place hot or chilled items directly on to the surface, use a place mat or marking will occur.
- For general cleaning use a soft cotton or micro fibre cloth, and do not use detergents of any kind.
- From time to time it may be necessary to tighten fittings, regular inspections should be carried out.
- Do not place on a wet or damp floor as staining may occur to your floor.

**TOOLS REQUIRED**

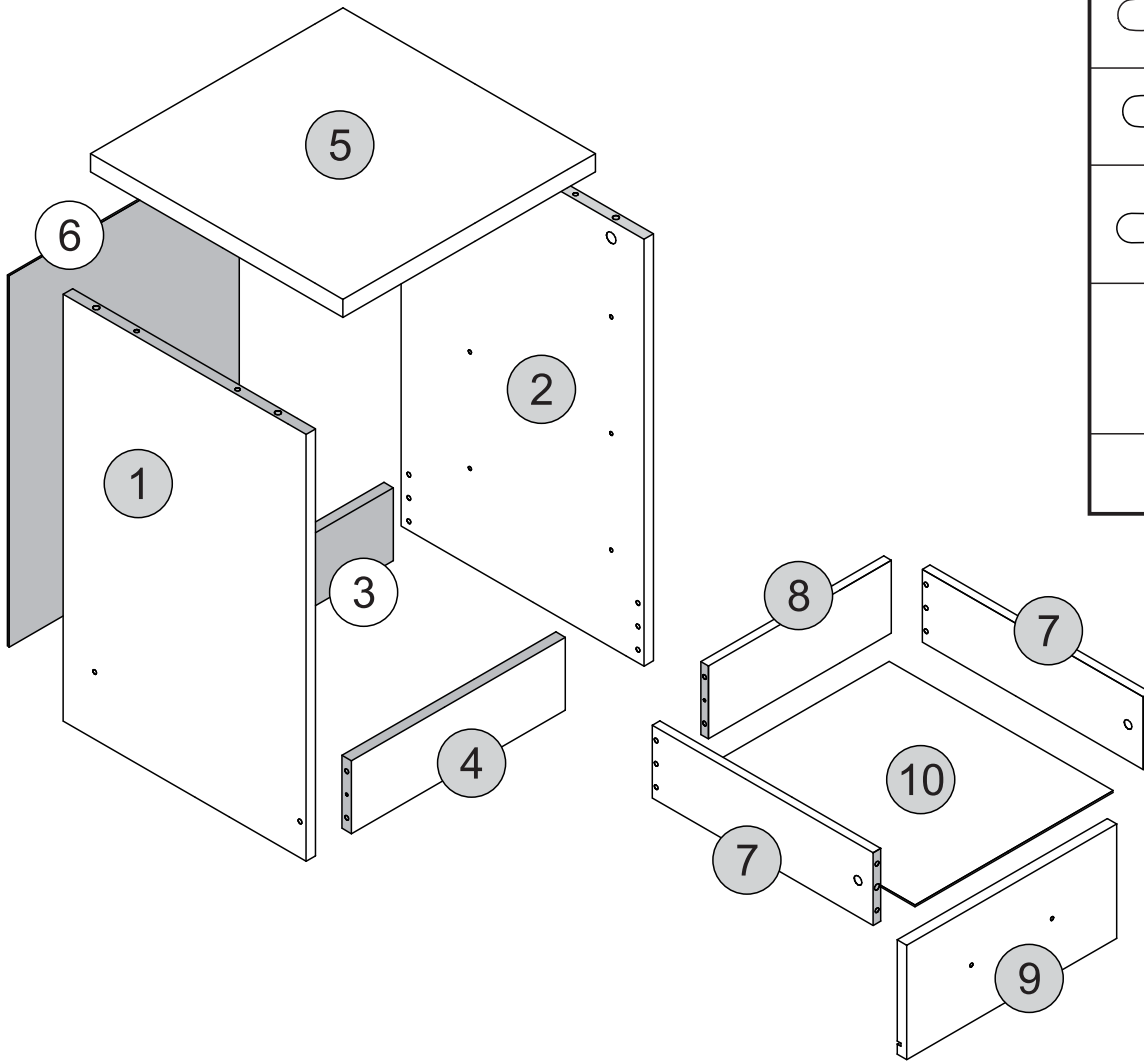
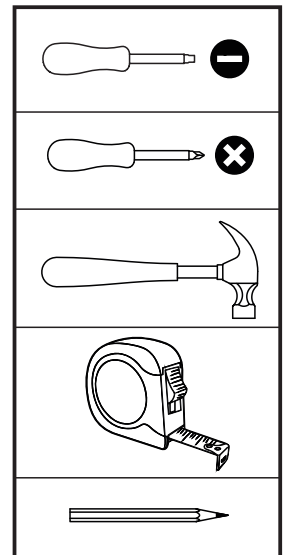







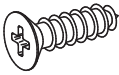
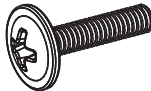

**PARTS LIST**

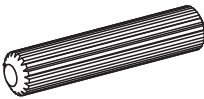
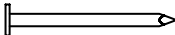
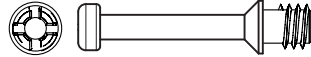
**Please Note:**  
The below parts have all been stamped with the part number to help identify them during assembly.

<b>Part Number</b>	<b>Part Code</b>	<b>Part Description</b>	<b>Quantity</b>	<b>Carton</b>
1	S100-103-077-DM1-01	Left Side Panel	1	1/1
2	S100-103-077-DM1-02	Right Side Panel	1	1/1
3	S100-103-077-DM1-03	Back Baseboard	1	1/1
4	S100-103-077-DM1-04	Front Baseboard	1	1/1
5	S100-103-077-DM1-05	Top Panel	1	1/1
6	S100-103-077-DM1-06	Back Panel	1	1/1
7	S100-103-077-DM1-07	Drawer Side	6	1/1
8	S100-103-077-DM1-08	Drawer Back Panel	3	1/1
9	S100-103-077-DM1-09	Drawer Front	3	1/1
10	S100-103-077-DM1-10	Drawer Bottom	3	1/1

# FITTINGS LIST

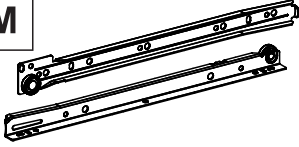
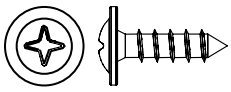
<p><b>A</b></p>  <p>Flat Head Screw Ø6,0 x 8mm (12x)</p> <p>2/+</p>	<p><b>B</b></p>  <p>Flat Head Screw Ø4,0 x 14mm (18x)</p> <p>2/+</p>	<p><b>C</b></p>  <p>Flan Head Screw Ø4,0 x 20mm (6x)</p> <p>1/+</p>	<p><b>D</b></p>  <p>Flat Head Screw Ø4,0 x 45mm (10x)</p> <p>2/+</p>
<p><b>E</b></p>  <p>Dowel Ø6,0 x 30mm (36x)</p> <p>2/+</p>	<p><b>F</b></p>  <p>Nail 10 x 10 (40x)</p> <p>5/+</p>	<p><b>G</b></p>  <p>Cam Bolt (10x)</p> <p>2/+</p>	<p><b>H</b></p>  <p>Cam Nut Ø12mm (10x)</p> <p>2/+</p>
<p><b>I</b></p>  <p>Plastic Foot (4x)</p> <p>1/+</p>	<p><b>J</b></p>  <p>Hole Plugs (16x)</p> <p>2/+</p>	<p><b>K</b></p>  <p>GLUE</p> <p>Glue (1x)</p>	<p><b>L</b></p>  <p>Handle (3x)</p>
<p><b>M</b></p>  <p>Drawer Runners (3x)</p>	<p><b>N</b></p>  <p>Flan Head Screw Ø3,5 x 12mm (2x)</p> <p>1/+</p>		

## TIPS FOR FITTINGS CAM-LOCKS

WHEN FITTING CAM NUT. ENSURE STARTING POSITION IS CORRECT BEFORE YOU INSERT CONNECTING CAM BOLT TURN CLOCKWISE UNTIL SECURE

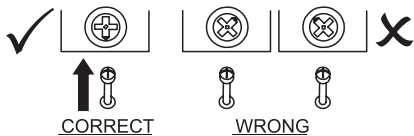

**CORRECT**      **WRONG**

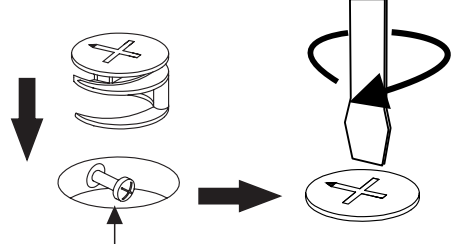

Cam bolt head needs to be in centre

### CAMBOLT

Tighten until shoulder in flush with panel. Do not overtighten or undertighten (see example beside)

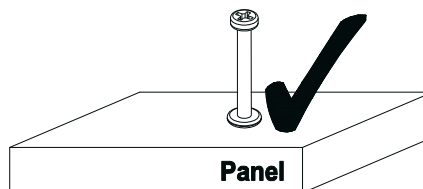
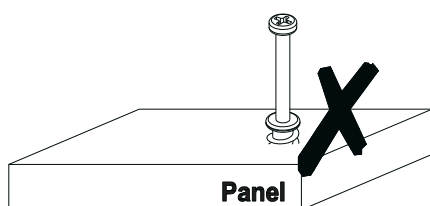
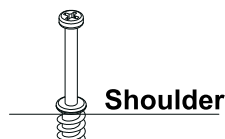



# STEP 1

## PARTS REQUIRED

1 - LEFT SIDE PANEL x1

## HARDWARE REQUIRED

E  02  
Ø6,0 x 30mm

F  02  
10 x 10

I  02

K  01  
GLUE

## TOOLS REQUIRED

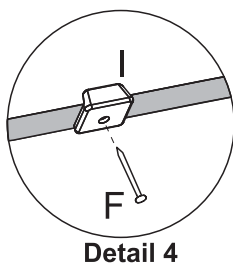
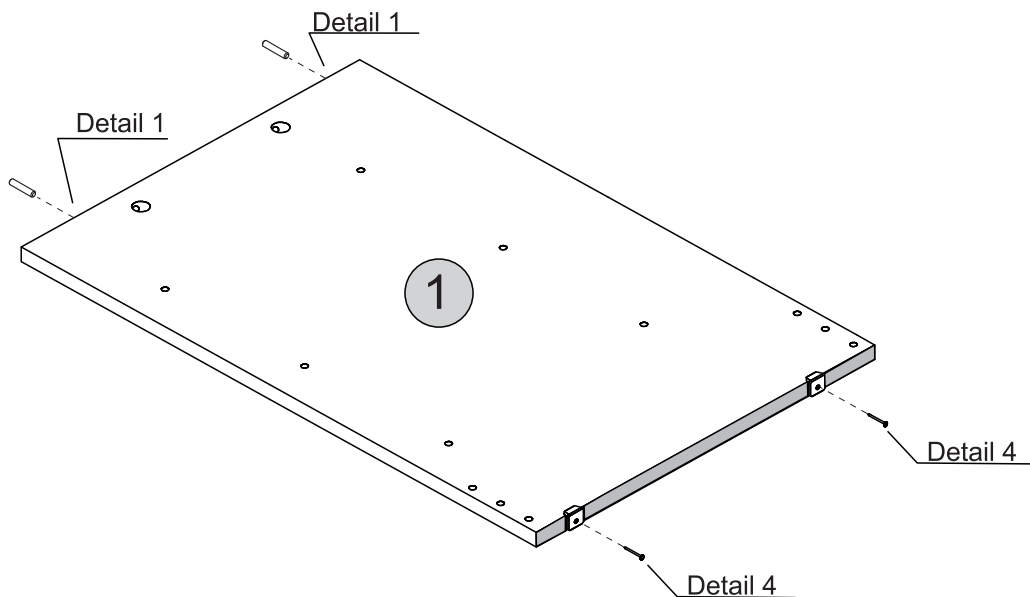
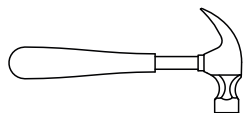



# STEP 2

## PARTS REQUIRED

2 - RIGHT SIDE PANEL x1

## HARDWARE REQUIRED

E  02  
Ø6,0 x 30mm

F  02  
10 x 10

I  02

K  01  
GLUE

## TOOLS REQUIRED

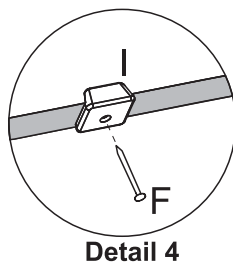
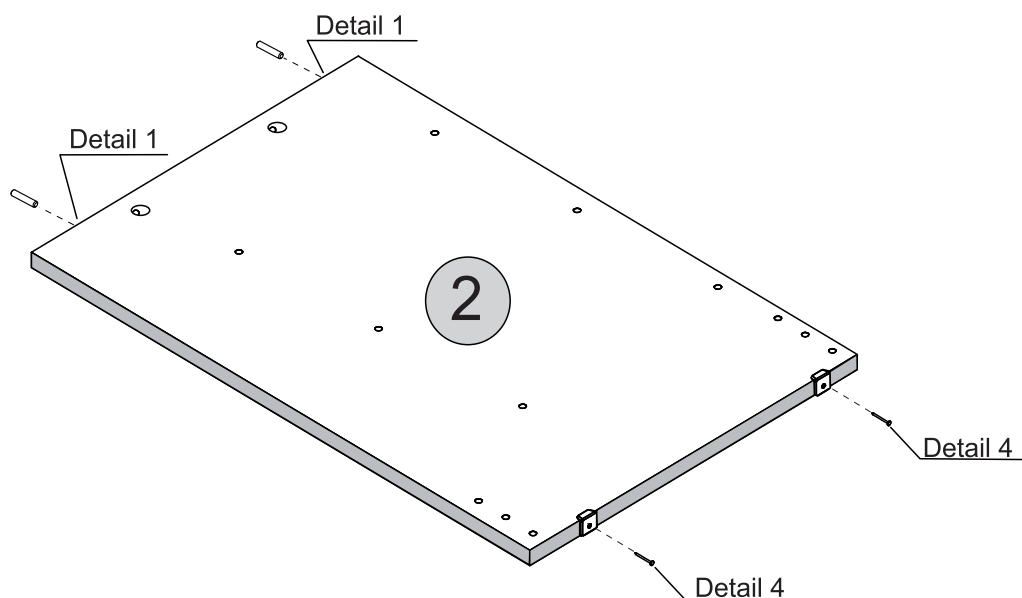
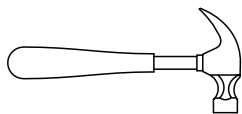

# STEP 3

## PARTS REQUIRED

2 - RIGHT SIDE PANEL x1

## HARDWARE REQUIRED

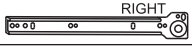
- A  06  
Ø6,0 x 8mm
- M  03  
RIGHT

## TOOLS REQUIRED

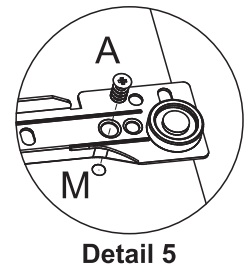
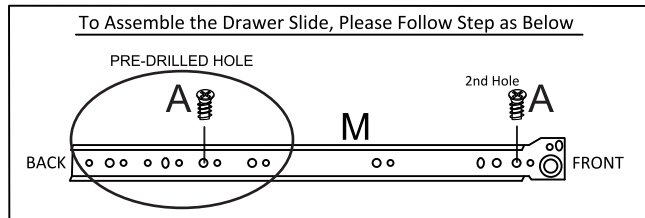
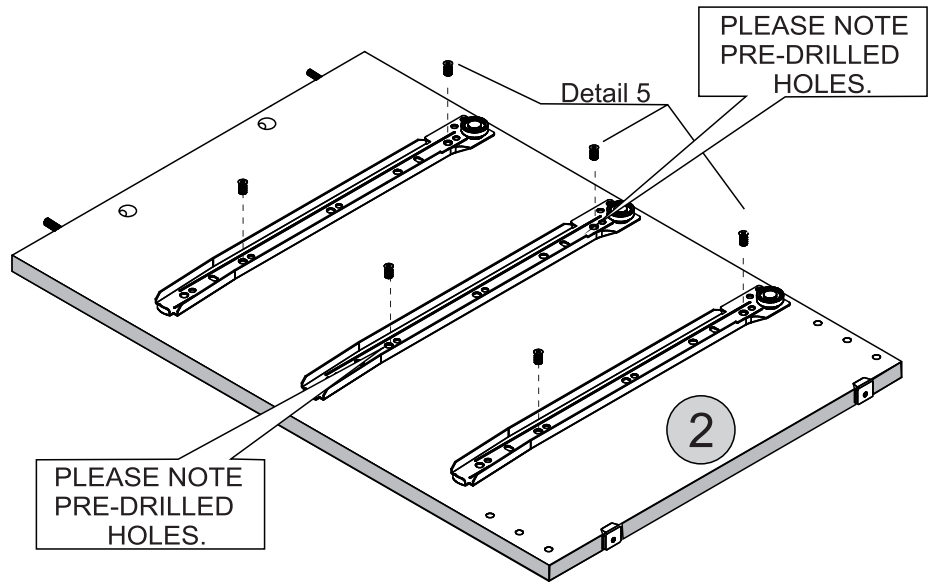
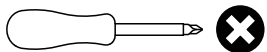



# STEP 4

## PARTS REQUIRED

1 - LEFT SIDE PANEL x1

## HARDWARE REQUIRED

- A  06  
Ø6,0 x 8mm
- M  03  
LEFT

## TOOLS REQUIRED

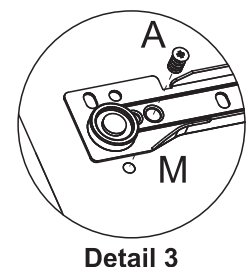
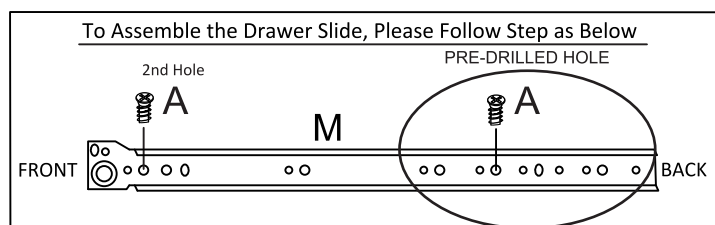
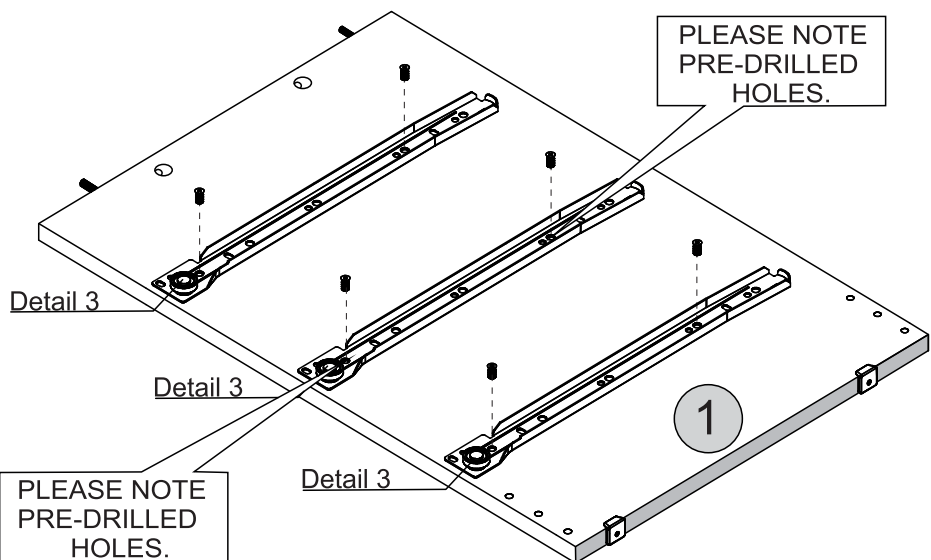
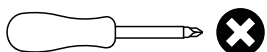



# STEP 5

## PARTS REQUIRED

3 - BACK BASEBOARD x1

4 - FRONT BASEBOARD x1

## HARDWARE REQUIRED

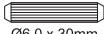
E  08  
Ø6,0 x 30mm

K  01

## TOOLS REQUIRED

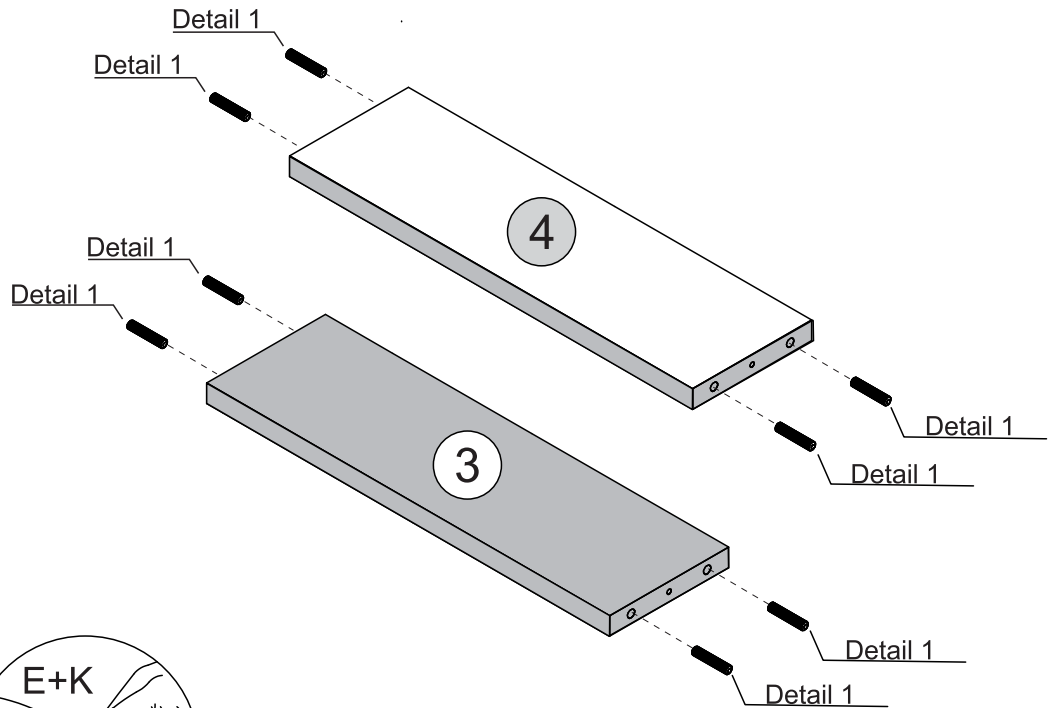

Detail 1

# STEP 6

## PARTS REQUIRED

2 - RIGHT SIDE PANEL x1

3 - BACK BASEBOARD x1

4 - FRONT BASEBOARD x1

## HARDWARE REQUIRED

D  02  
Ø4,0 x 45mm

K  01

## TOOLS REQUIRED

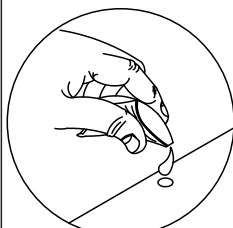
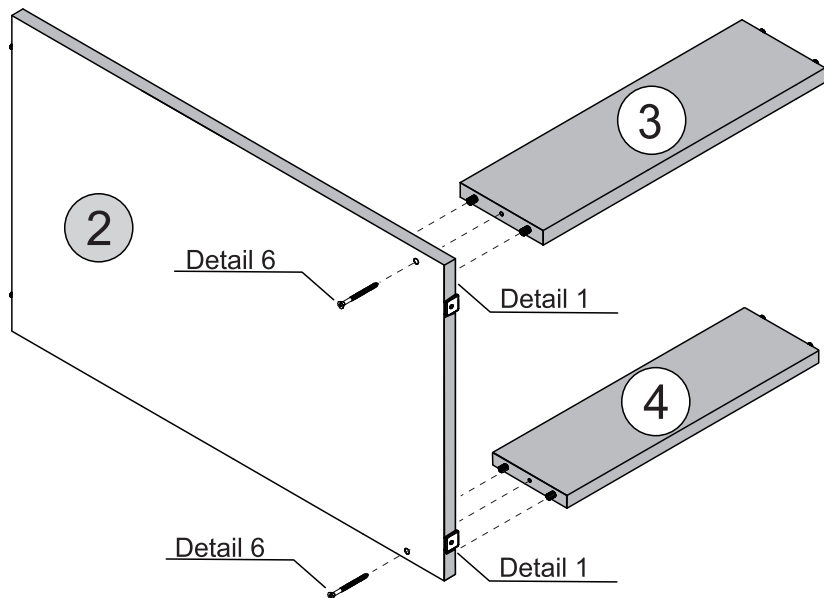
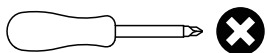

Detail 1

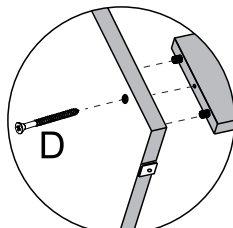

Detail 6

# STEP 7

## PARTS REQUIRED

1 - LEFT SIDE PANEL x1

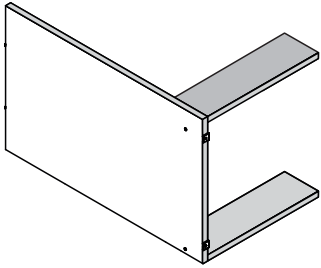

## HARDWARE REQUIRED

D  Ø4,0 x 45mm 02

K  GLUE 01

## TOOLS REQUIRED

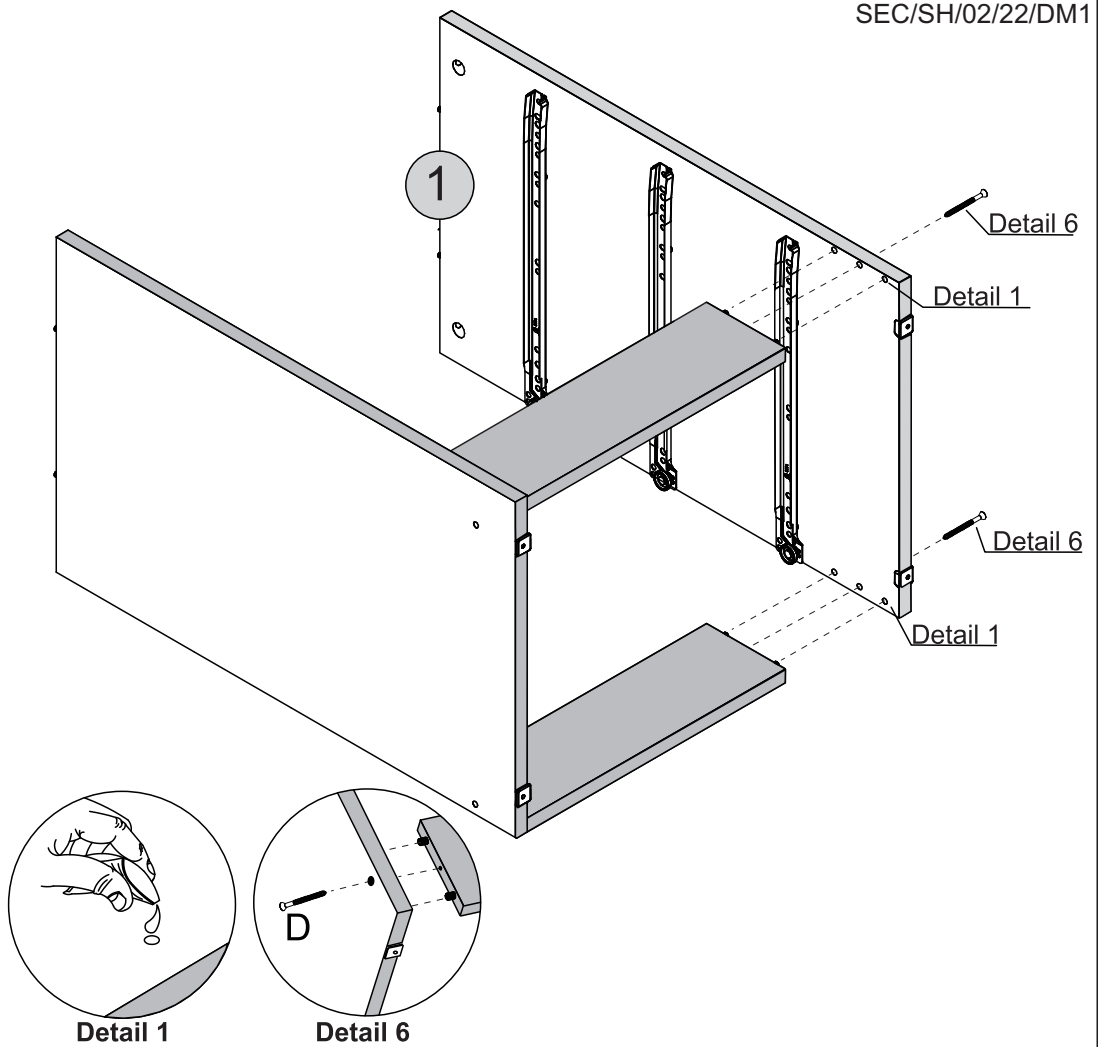
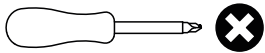

Detail 1

Detail 6

# STEP 8

## PARTS REQUIRED

5 - TOP PANEL x1

## HARDWARE REQUIRED

G  04

## TOOLS REQUIRED

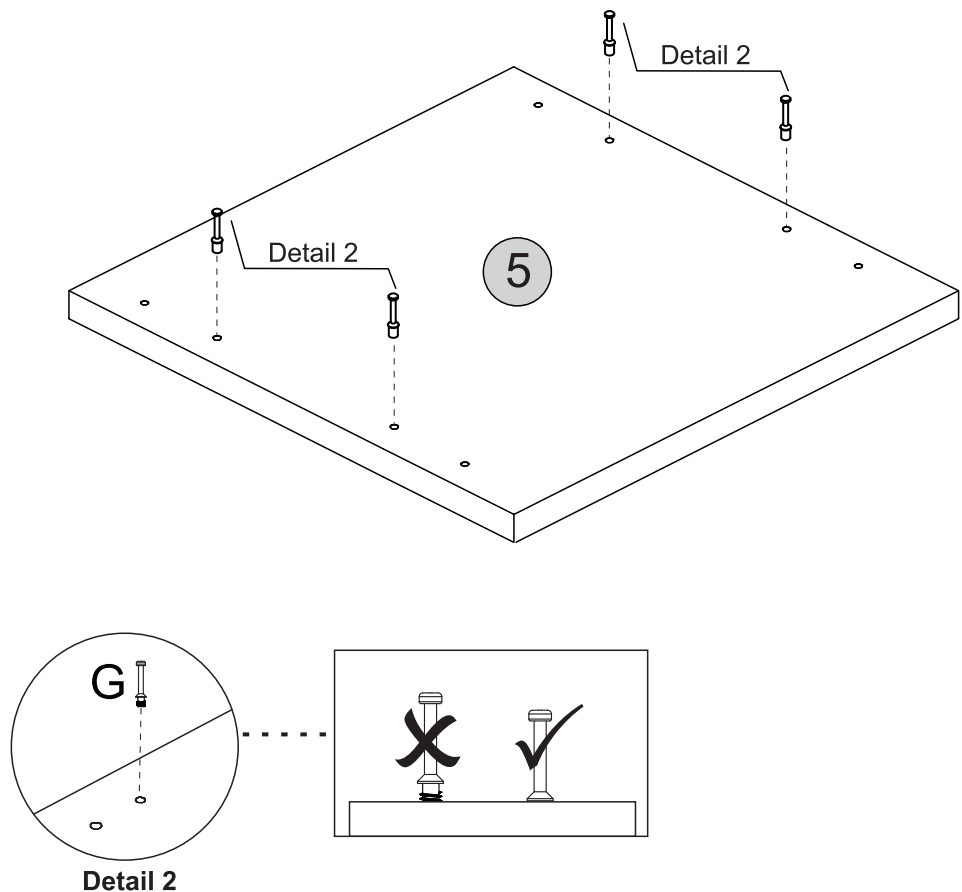
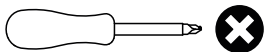

Detail 2

# STEP 9

### PARTS REQUIRED

5 - TOP PANEL x1

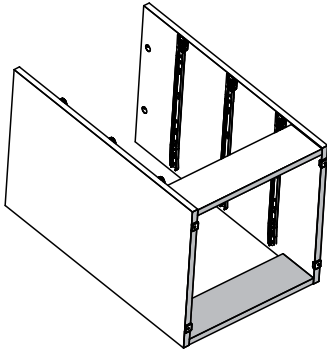

### HARDWARE REQUIRED

H  04

K  GLUE 01

### TOOLS REQUIRED

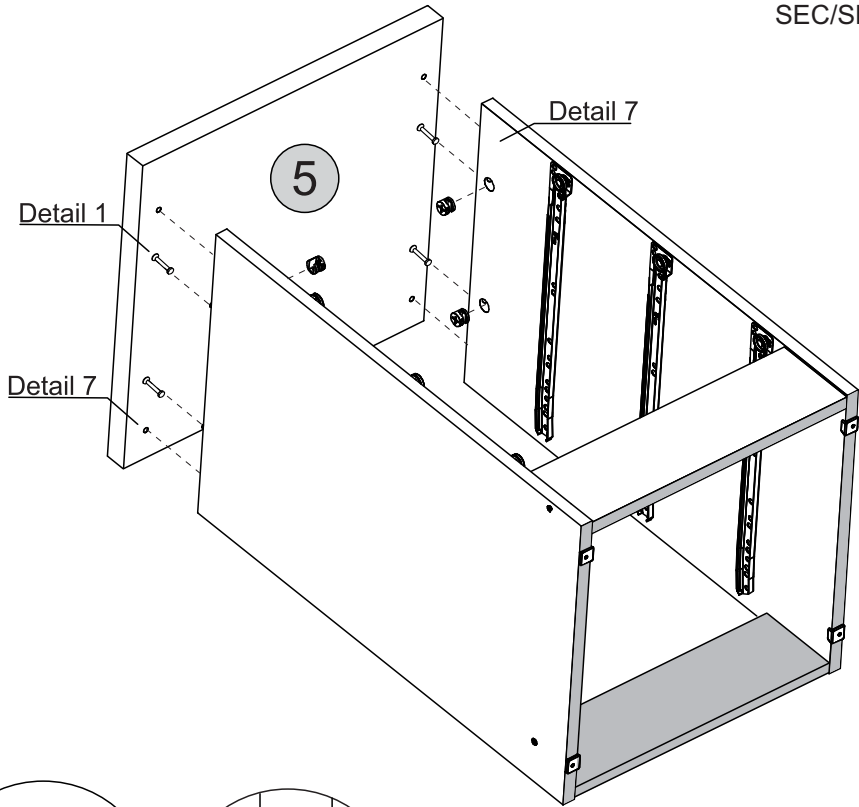
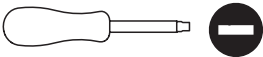

Detail 1

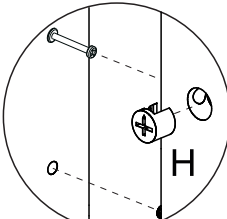

Detail 7

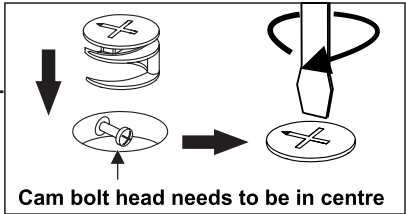

Cam bolt head needs to be in centre

# STEP 10

### PARTS REQUIRED

6 - BACK PANEL x1

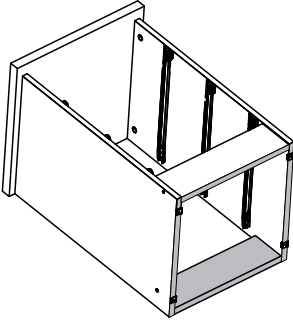

### HARDWARE REQUIRED

F  10 x 10 12

N  Ø3,5 x 12mm 02

### TOOLS REQUIRED

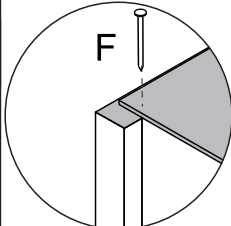
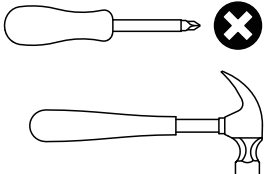

Detail 8

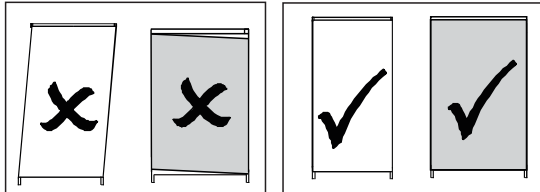

\* For your future reference Order Number should be here

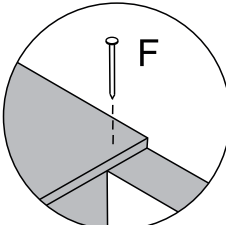
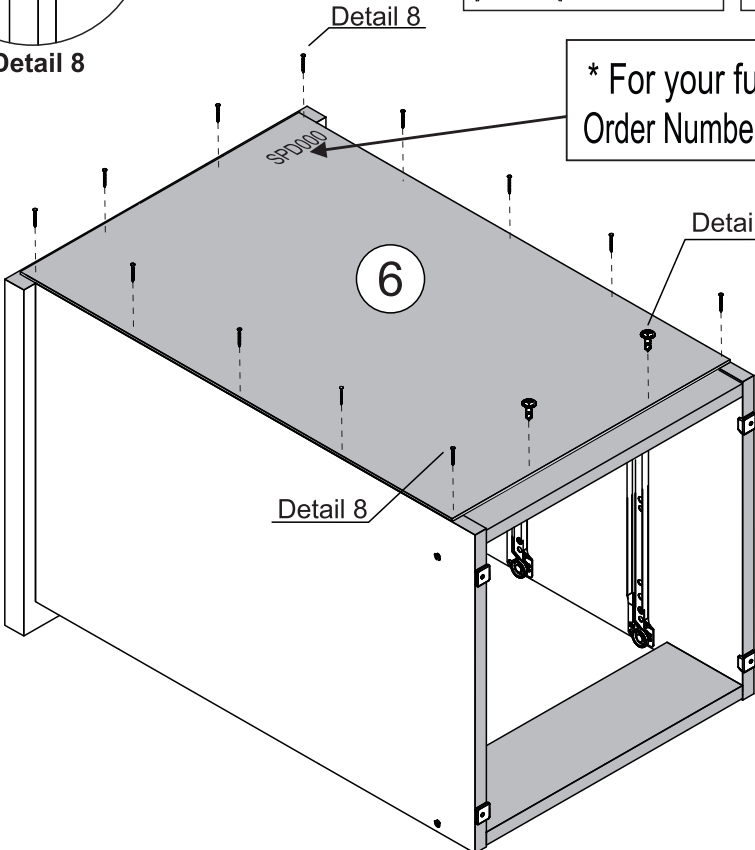

Detail 8

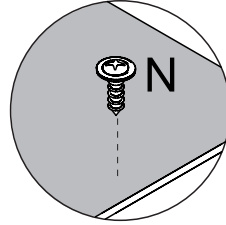

Detail 16

# STEP 11

SEC/SH/02/22/DM1

## PARTS REQUIRED

7 - DRAWER SIDE x6

8 - DRAWER BACK PANEL x3

9 - DRAWER FRONT x3

## HARDWARE REQUIRED

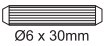
E  24  
Ø6 x 30mm

G  06

K  01

## TOOLS REQUIRED

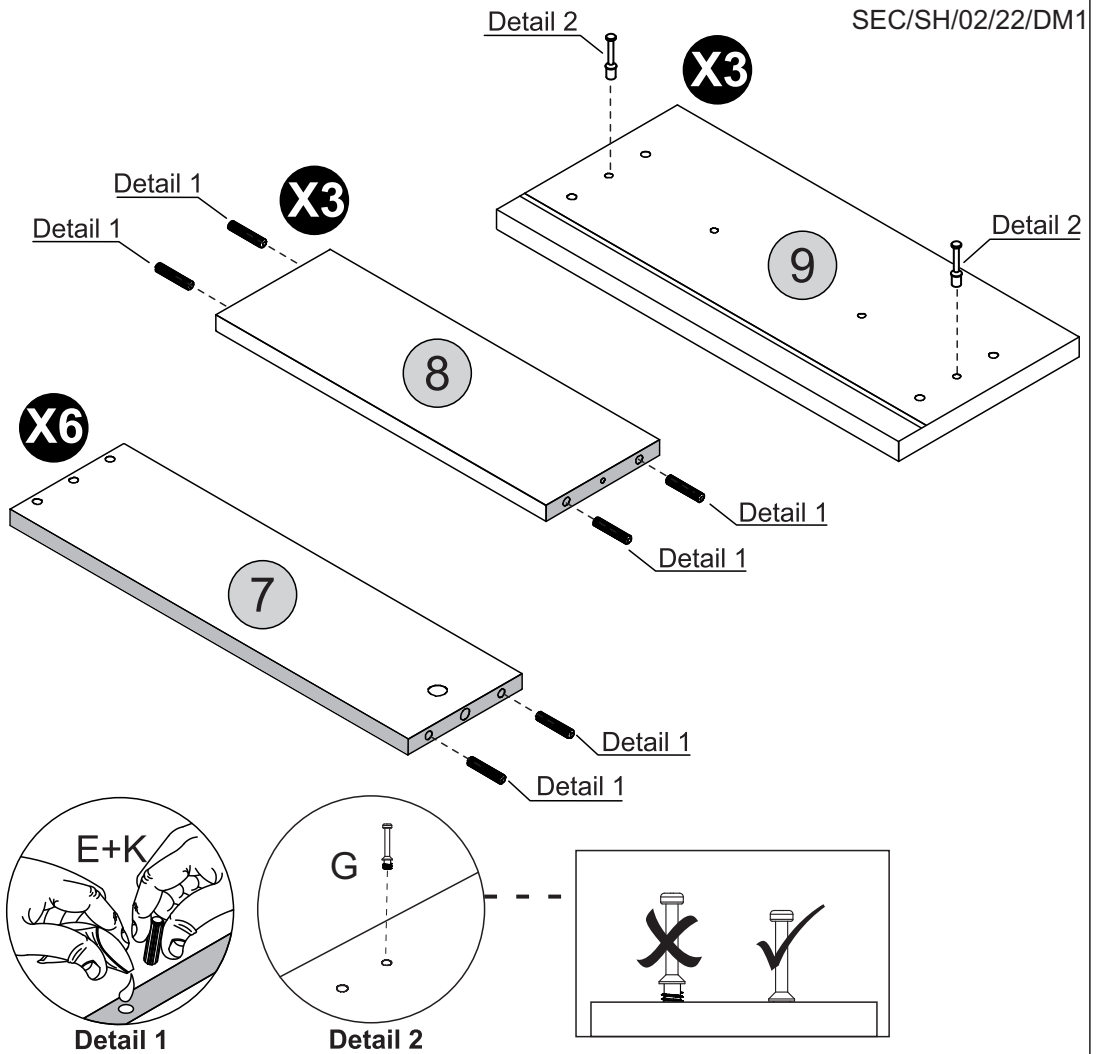
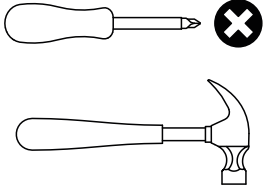

# STEP 12

## PARTS REQUIRED

7 - DRAWER SIDE x6

8 - DRAWER BACK PANEL x3

## HARDWARE REQUIRED

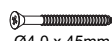
D  06  
Ø4,0 x 45mm

## TOOLS REQUIRED

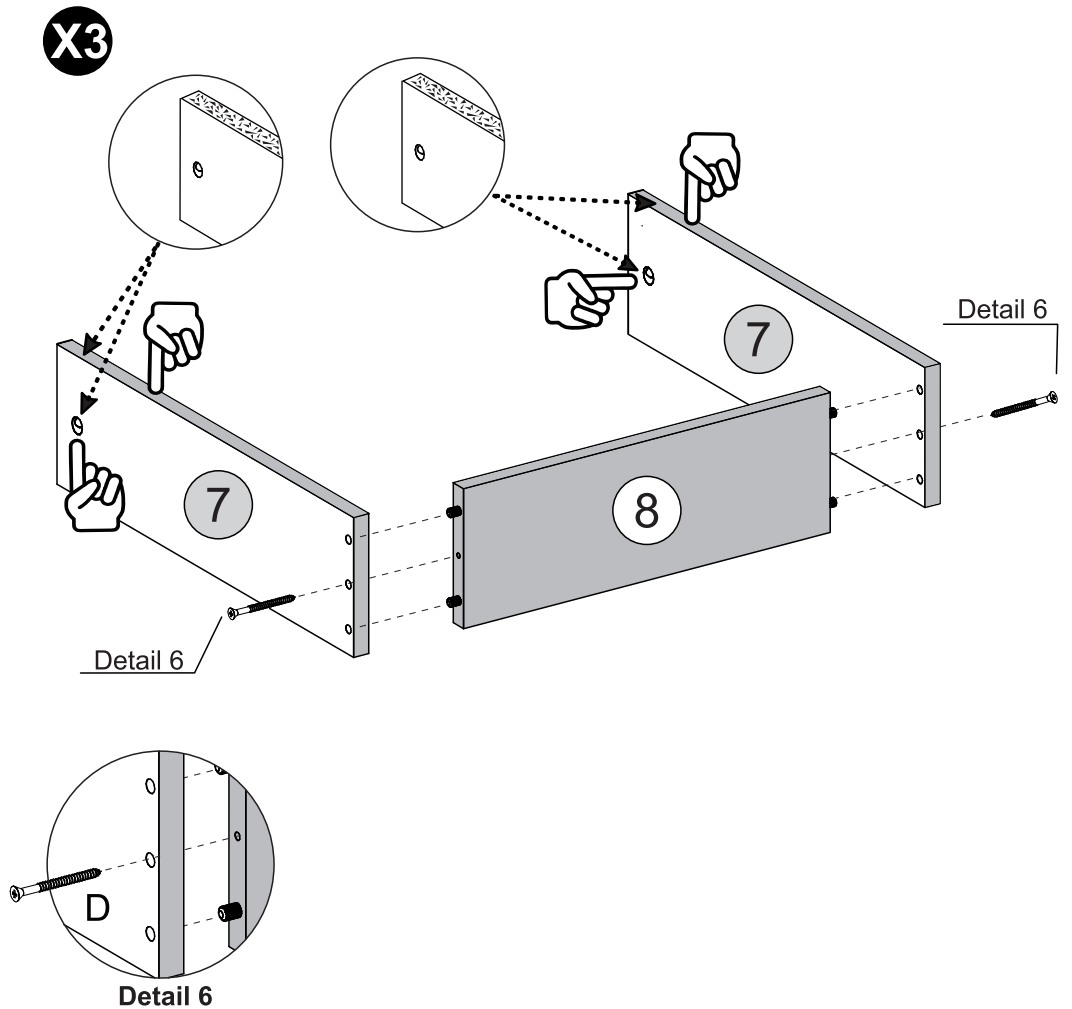
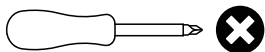

# STEP 13

## PARTS REQUIRED

9 - DRAWER FRONT x3

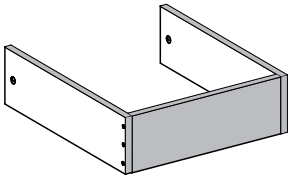

## HARDWARE REQUIRED

K  01

## TOOLS REQUIRED

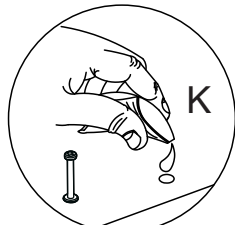

Detail 1

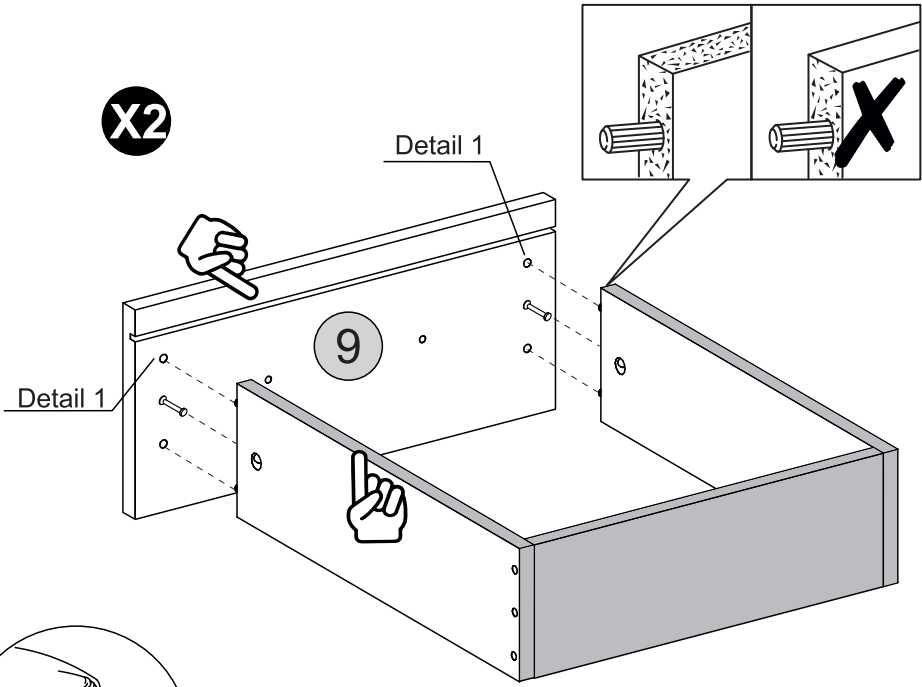

# STEP 14

## PARTS REQUIRED

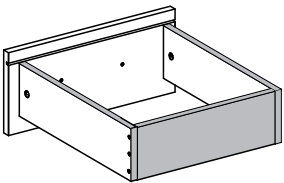

## HARDWARE REQUIRED

H  06

J  12

## TOOLS REQUIRED

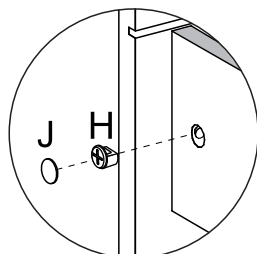
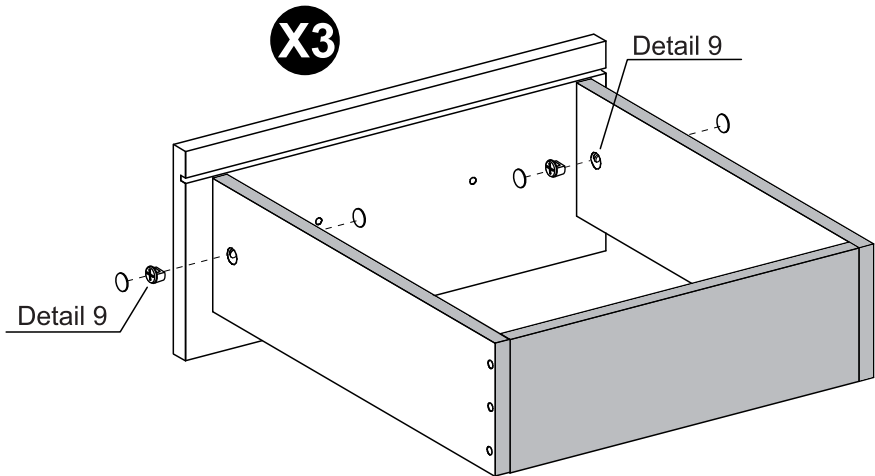
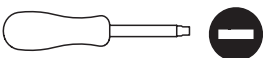

Detail 9

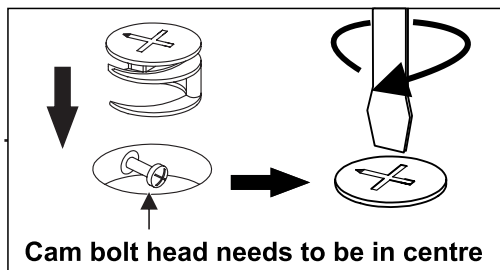

# STEP 15

SEC/SH/02/22/DM1

## PARTS REQUIRED

10 - DRAWER BOTTOM x3

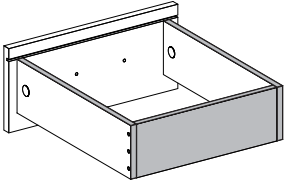

## HARDWARE REQUIRED

F 10 x 10 12

## TOOLS REQUIRED

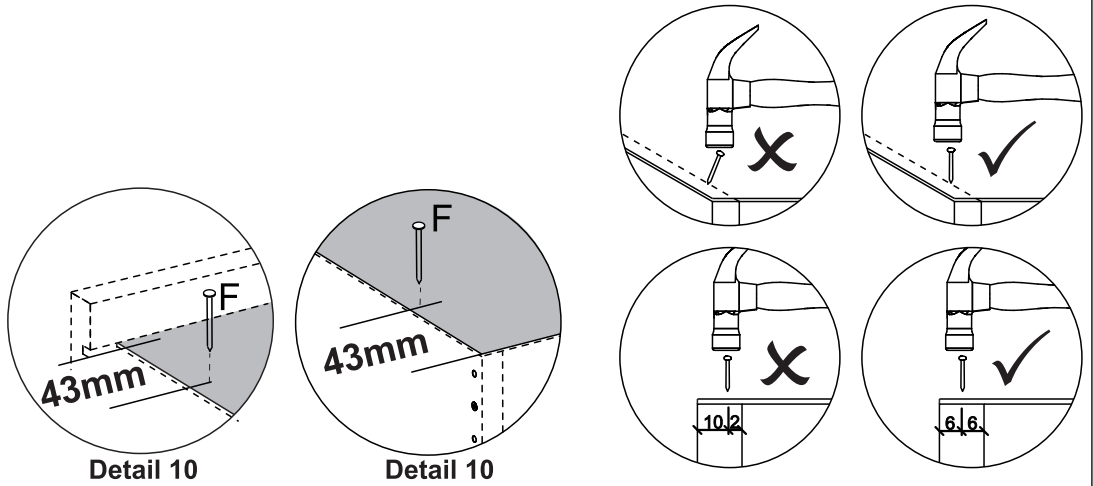
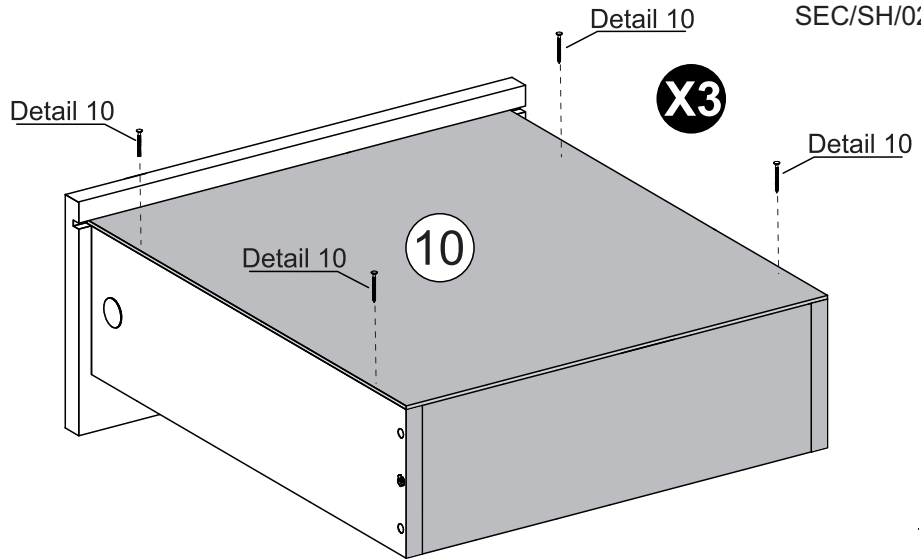
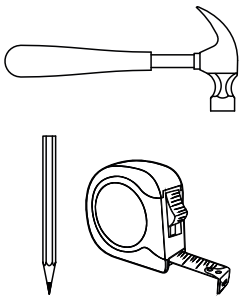

# STEP 16

## PARTS REQUIRED

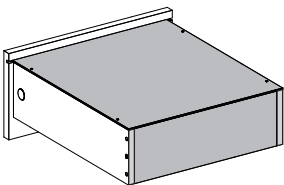

## HARDWARE REQUIRED

F 10 x 10 12

## TOOLS REQUIRED

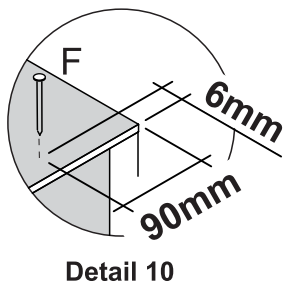
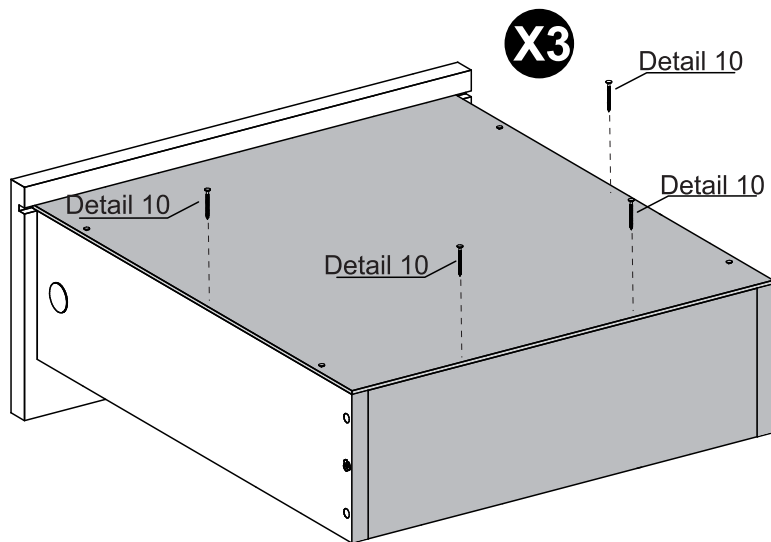
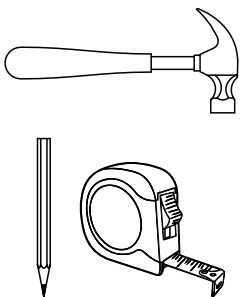

# STEP 17

**PARTS REQUIRED**

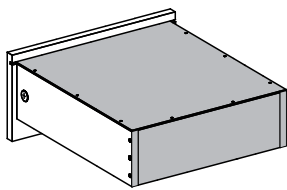

**HARDWARE REQUIRED**

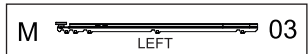
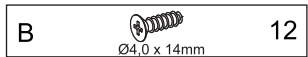

**TOOLS REQUIRED**

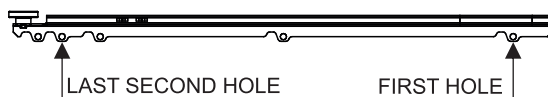
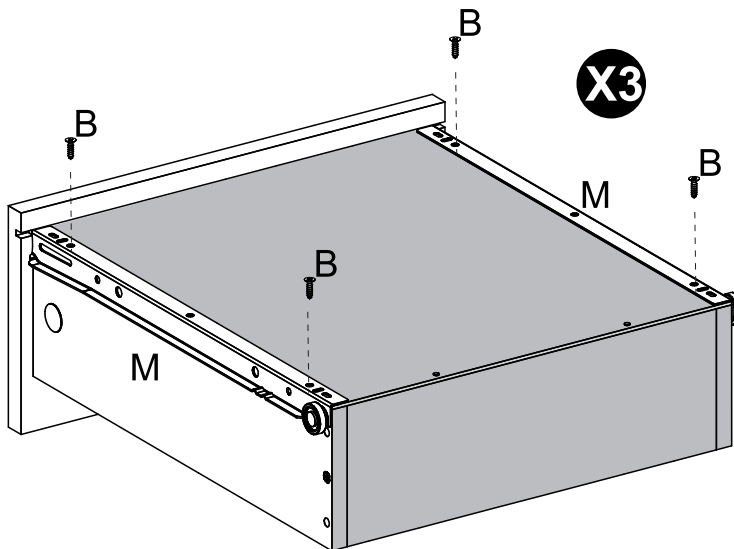
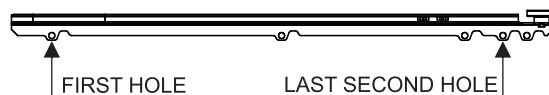
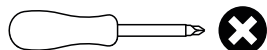

# STEP 18

**PARTS REQUIRED**

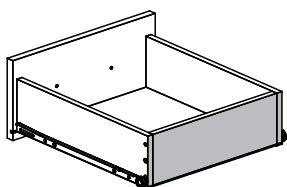

**HARDWARE REQUIRED**

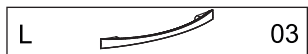

**TOOLS REQUIRED**

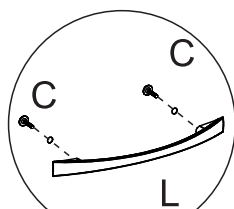
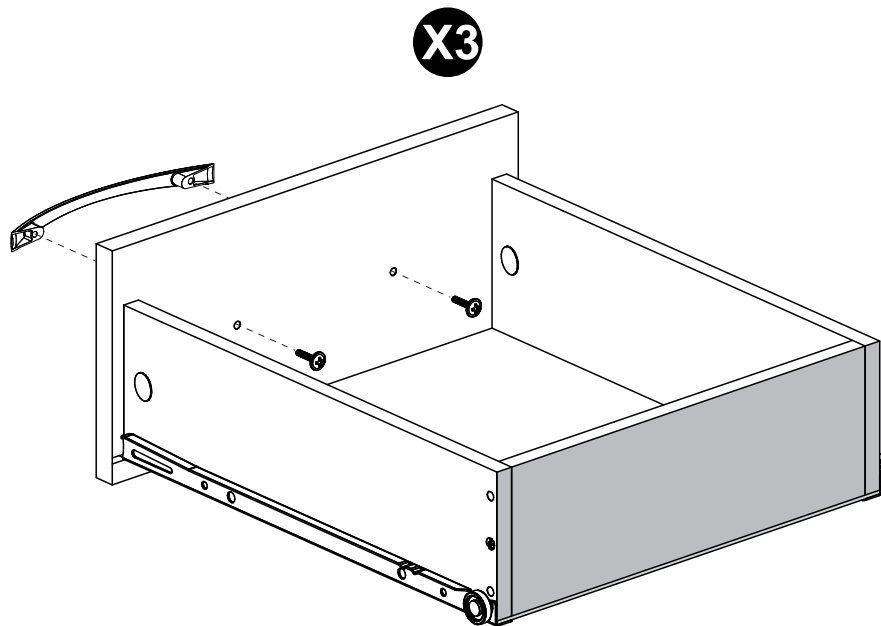
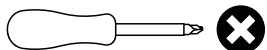

Detail 11

# STEP 19

## PARTS REQUIRED

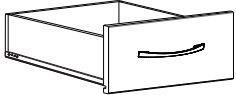
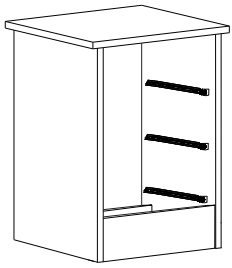

## HARDWARE REQUIRED



## TOOLS REQUIRED

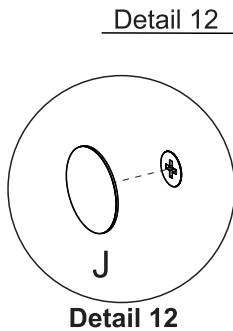
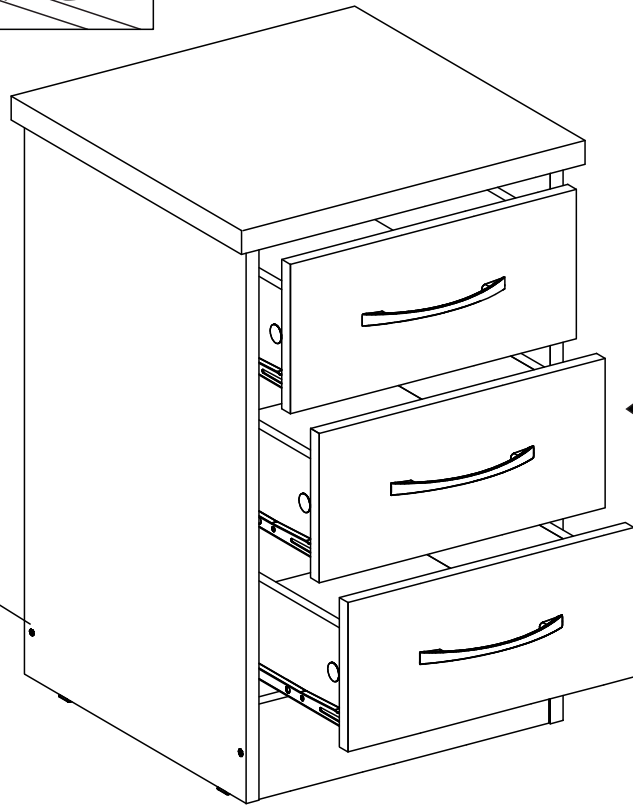
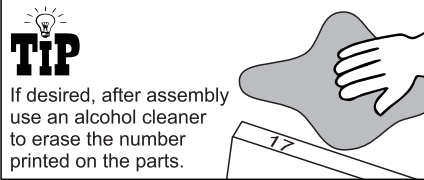

# STEP 20

## PARTS REQUIRED

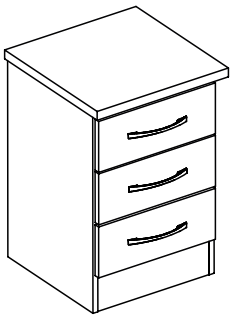

## HARDWARE REQUIRED

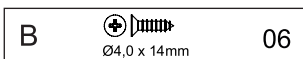

## TOOLS REQUIRED

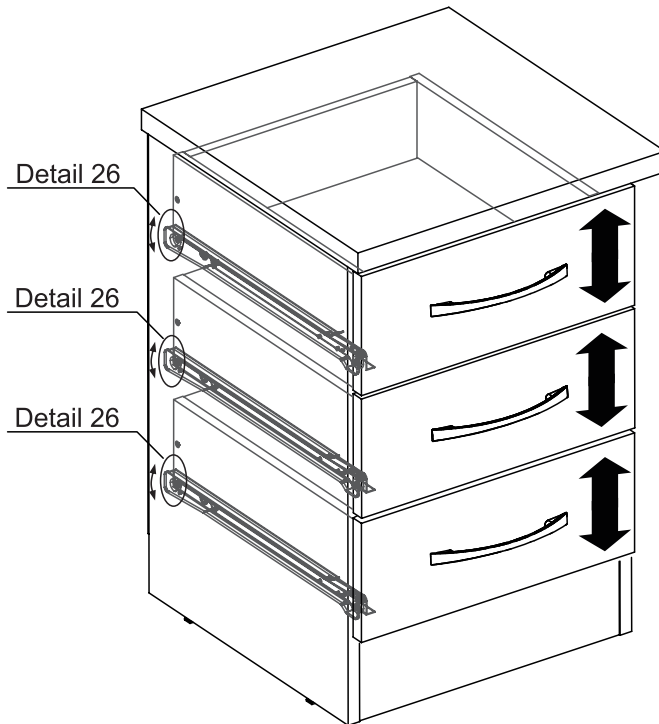
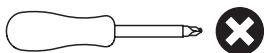

### Drawer Adjustment

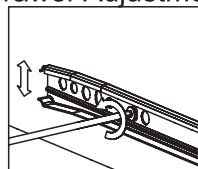

### Drawer Lock

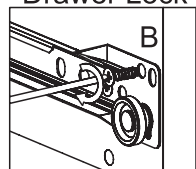

Detail 26