

# WHITE / OAK EFFECT PORTLAND 5 DRAWER NARROW CHEST ASSEMBLY INSTRUCTIONS

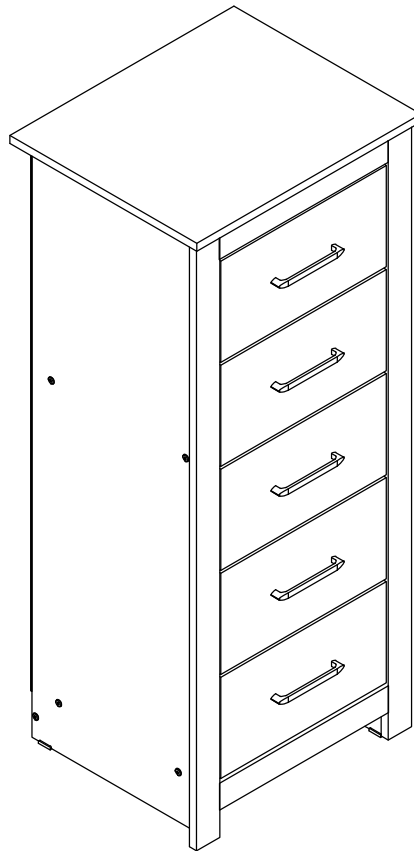
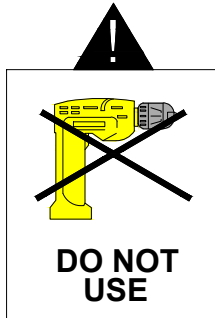

## **IMPORTANT FOR DOMESTIC USE ONLY PLEASE READ BEFORE YOU CONTINUE FURTHER**

THE PRODUCT YOU HAVE PURCHASED WILL GIVE YOU MANY YEARS OF SERVICE IF YOU FOLLOW THE GUIDELINES FOR ITS SAFE ASSEMBLY AND PERIODIC MAINTENANCE AND CLEANING.

ASSEMBLE ON A SOFT CLEAN SURFACE.

DO NOT USE ANY TOOLS OTHER THAN THOSE SHOWN.

ANY SPANNERS OR ALLEN KEYS REQUIRED ARE INCLUDED WITH THE FITTINGS KIT.

DO NOT FOR ANY REASON USE A POWER TOOL TO ASSEMBLE THIS PRODUCT. ITS USE WILL INVALIDATE ANY CLAIM YOU MAY HAVE AND COULD MAKE THIS PRODUCT UNSAFE.

DEPENDING ON THE AMOUNT OF USE THIS PRODUCT RECEIVES IT MAY BE NECESSARY TO TIGHTEN UP THE FIXINGS FROM TIME TO TIME. THIS IS COMPLETELY NORMAL FOR ANY FLAT PACK FURNITURE. DO NOT OVERTIGHTEN FIXING.

FOR CLEANING, YOU MAY USE A DAMP CLOTH (NOT WET) DO NOT USE POLISH, DETERGENT OR CHEMICAL CLEANERS.



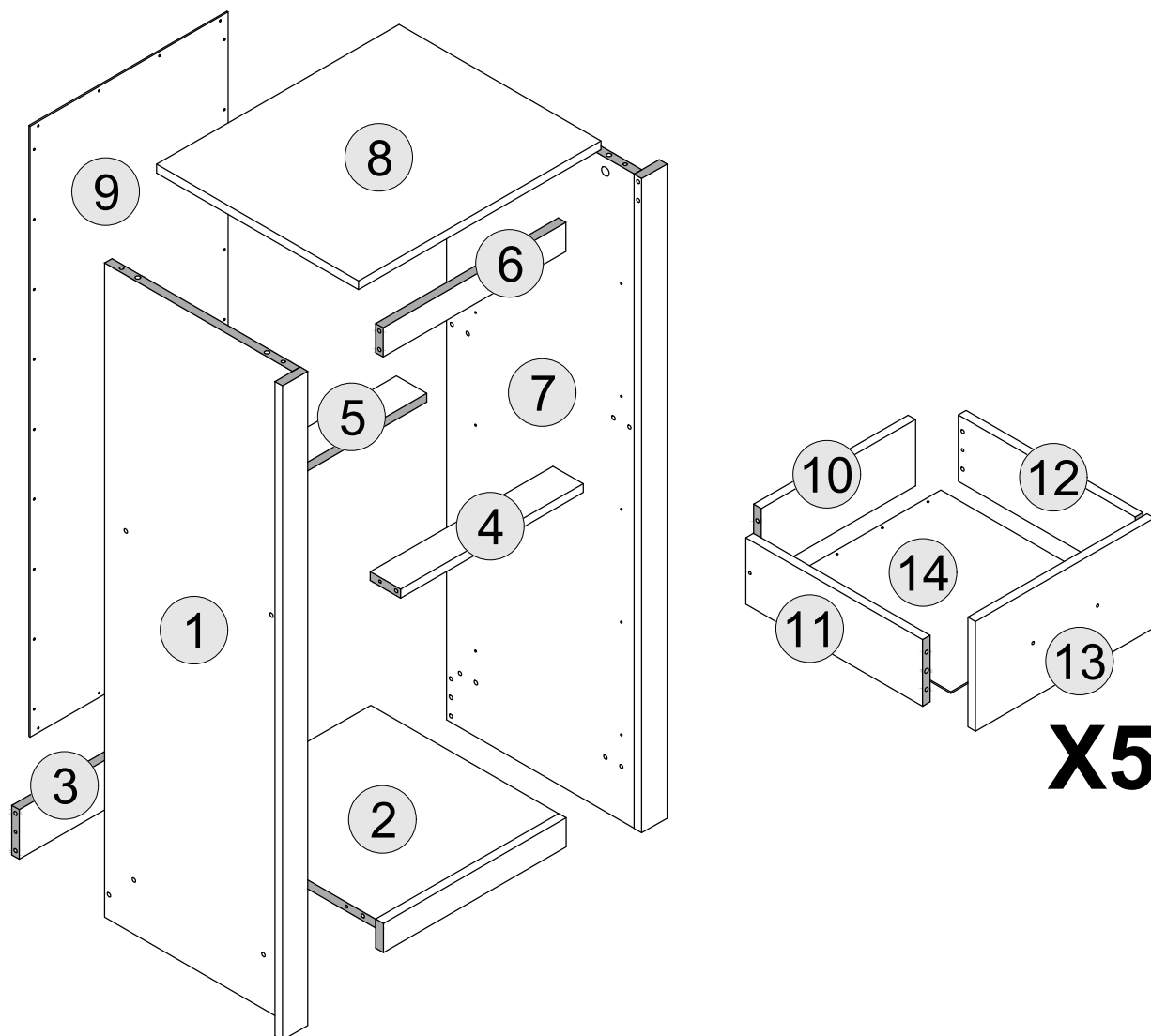









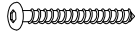

THE SURFACE OF THIS ITEM IS NOT HEAT RESISTANT. ALWAYS USE A PLACE MAT UNDER HOT OR COLD ITEMS TO PREVENT MARKING.

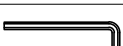

## PART LIST

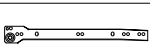
Part Number	Part Code	Part Description	Quantity	Carton
1	S100-102-183-EU1-01	Side Panel - Left	1	1/1
2	S100-102-183-EU1-02	Bottom Panel	1	1/1
3	S100-102-183-EU1-03	Base Apron	1	1/1
4	S100-102-183-EU1-04	Front Crossbar	1	1/1
5	S100-102-183-EU1-05	Back Crossbar	1	1/1
6	S100-102-183-EU1-06	Top Frame	1	1/1
7	S100-102-183-EU1-07	Side Panel - Right	1	1/1
8	S100-102-183-EU1-08	Top Panel	1	1/1
9	S100-102-183-EU1-09	Back Panel	1	1/1
10	S100-102-183-EU1-10	Drawer Back	5	1/1
11	S100-102-183-EU1-11	Drawer Side - Left	5	1/1
12	S100-102-183-EU1-12	Drawer Side - Right	5	1/1
13	S100-102-183-EU1-13	Drawer Front	5	1/1
14	S100-102-183-EU1-14	Drawer Base	5	1/1

## HARDWARE LIST

A		DOWEL 6 X 30MM	60 PCS
B		CAM BOLT + CAM NUT	14 SETS
C		BOLT M6 X 50MM	10 PCS
D		SCREW M3.5 X 16MM	34 PCS
E		TACK	26 PCS
F		PLASTIC FOOT	4 PCS
G		SCREW M3.5 X 12MM	60 PCS
H		HANDLE	5 PCS
I		ALLEN KEY	1 PC
J		SCREW M4 X 38MM	10 PCS
K		HANDLE SCREW 20MM	10 PCS
L		DRAWER RUNNER A - L/R	10 PCS
M		DRAWER RUNNER B - L/R	10 PCS
N		ANTI - TIP STRAP	2 PCS
O		SCREW M4 X 16MM	2 PCS

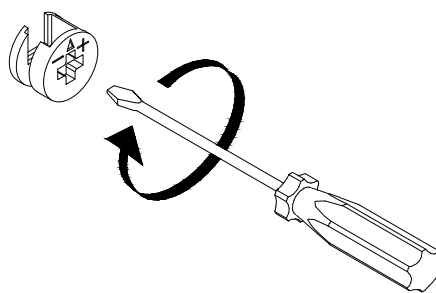

(SCREWDRIVER NOT PROVIDED)

USE A FLAT HEAD SCREWDRIVER TO TIGHTEN THE CAM NUTS. A QUARTER TURN CLOCKWISE IS ALL THAT IS NEEDED.

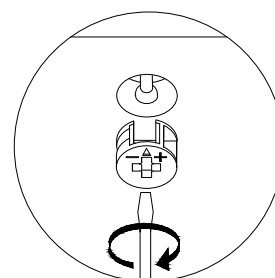
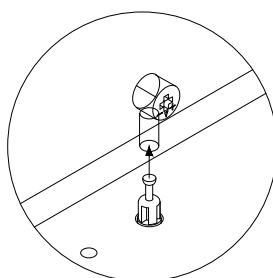
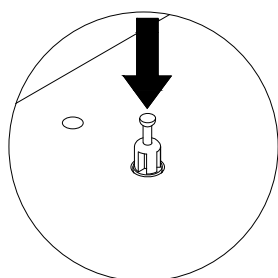

STEP 1 - PUSH CAM BOLT INTO INSERT

STEP 2 - ALIGN THE CAM BOLT WITH THE HOLE AND PUSH TOGETHER UNTIL FLUSH. ( MAKE SURE THE ARROW OF THE CAM LOCK IS POINTING TOWARD THE EDGE OF THE PANEL.)

STEP 3 - THE HEAD OF THE BOLT GOES INTO THE WIDE MOUTH OF THE CAM LOCK. YOU THEN TURN THE LOCK SO THE NARROW PART CLOSES OVER THE BOLT.

# STEP 1

**PARTS REQUIRED**

1 - SIDE PANEL - LEFT x1

**HARDWARE REQUIRED**

A  02

B  02

G  20

L  05

**TOOLS REQUIRED**

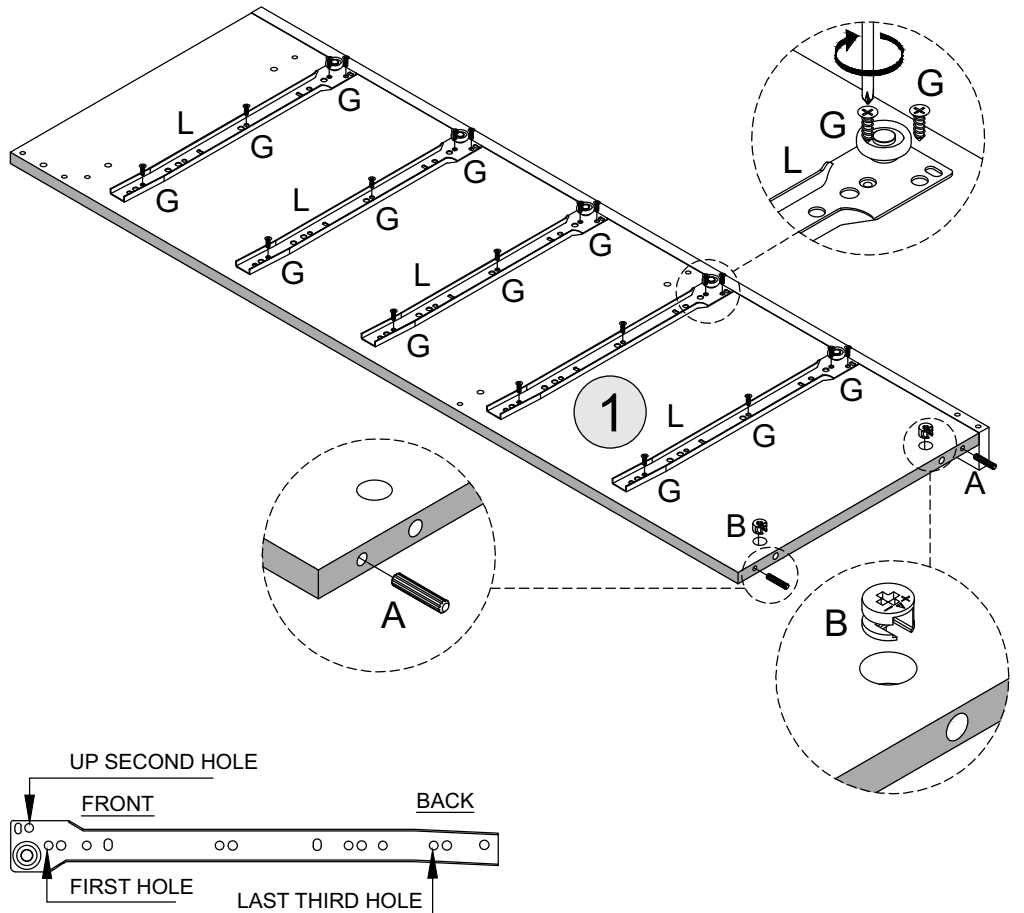
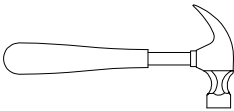
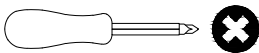

# STEP 2

**PARTS REQUIRED**

7 - SIDE PANEL - RIGHT x1

**HARDWARE REQUIRED**

A  02

B  02

G  20

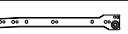
L  05

**TOOLS REQUIRED**

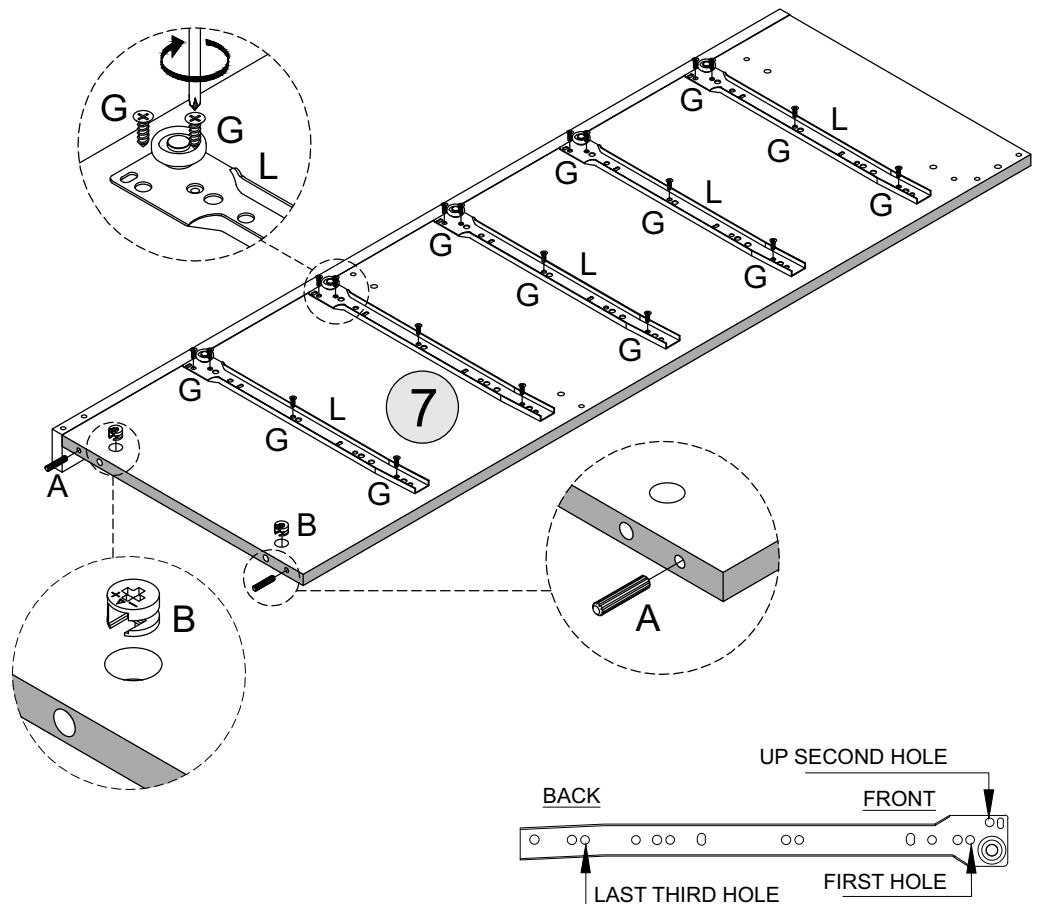
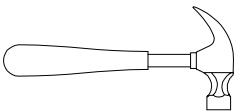
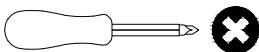

# STEP 3

PARTS REQUIRED

3 - BASE APRON	x1
4 - FRONT CROSSBAR	x1
5 - BACK CROSSBAR	x1
6 - TOP FRAME	x1

HARDWARE REQUIRED

A		12
---	---	----

TOOLS REQUIRED

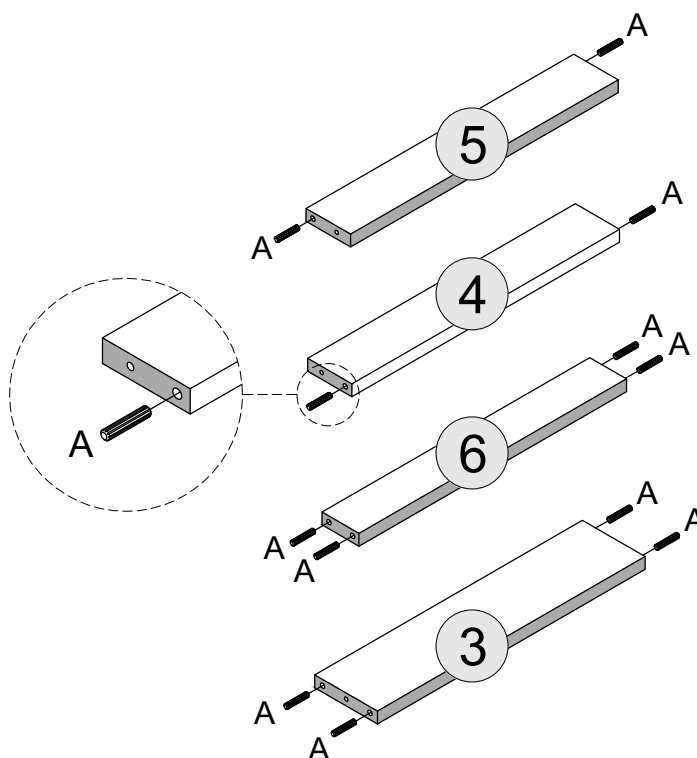
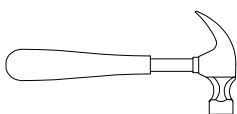

# STEP 4

PARTS REQUIRED

2 - BOTTOM PANEL	x1
8 - TOP PANEL	x1

HARDWARE REQUIRED

A		04
---	---	----

B		04
---	---	----

TOOLS REQUIRED

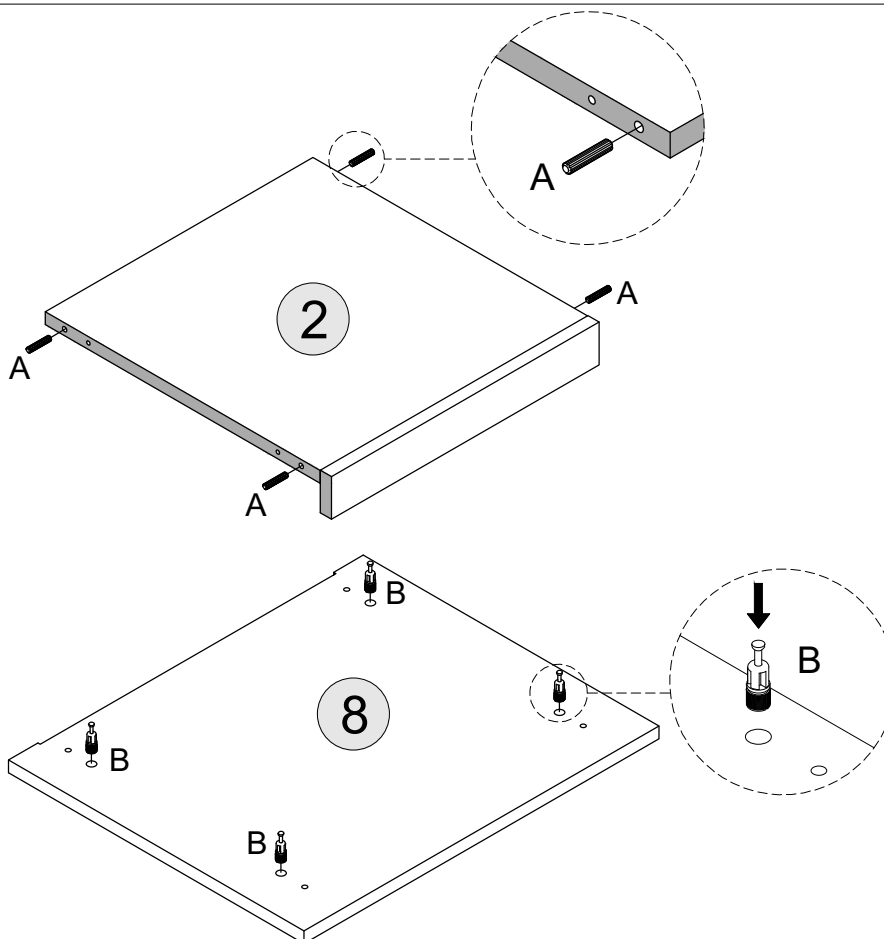
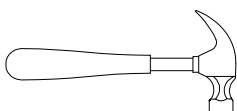

# STEP 5

PARTS REQUIRED

- 1 - SIDE PANEL - LEFT      x1
- 2 - BOTTOM PANEL            x1

HARDWARE REQUIRED

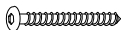
- C  02

TOOLS REQUIRED

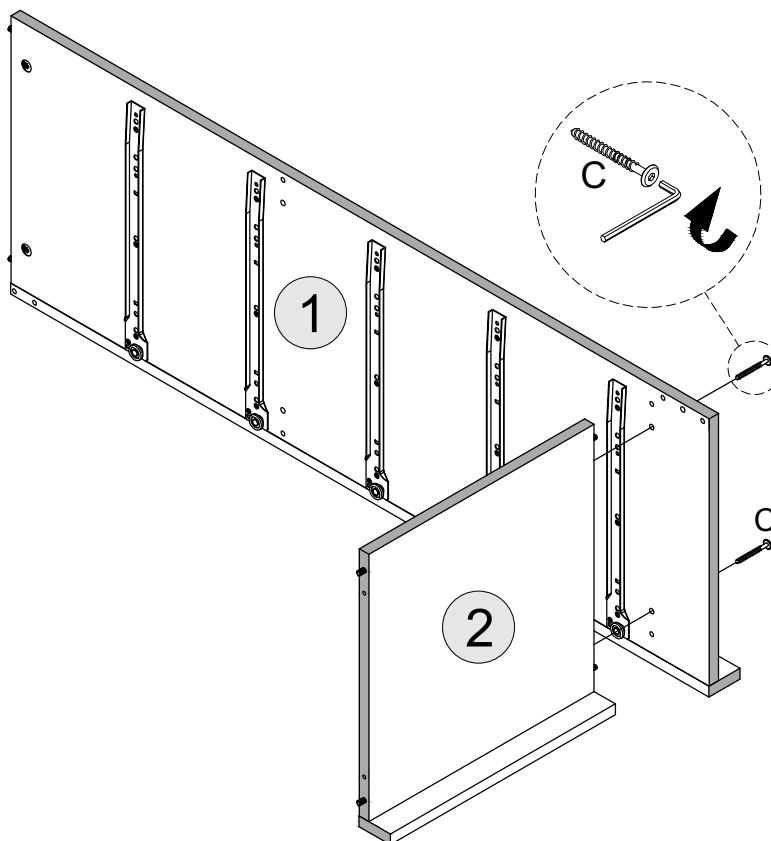

# STEP 6

PARTS REQUIRED

- 3 - BASE APRON            x1
- 4 - FRONT CROSBAR        x1
- 5 - BACK CROSBAR        x1
- 6 - TOP FRAME              x1

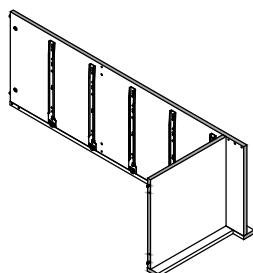

HARDWARE REQUIRED

- C  03

TOOLS REQUIRED

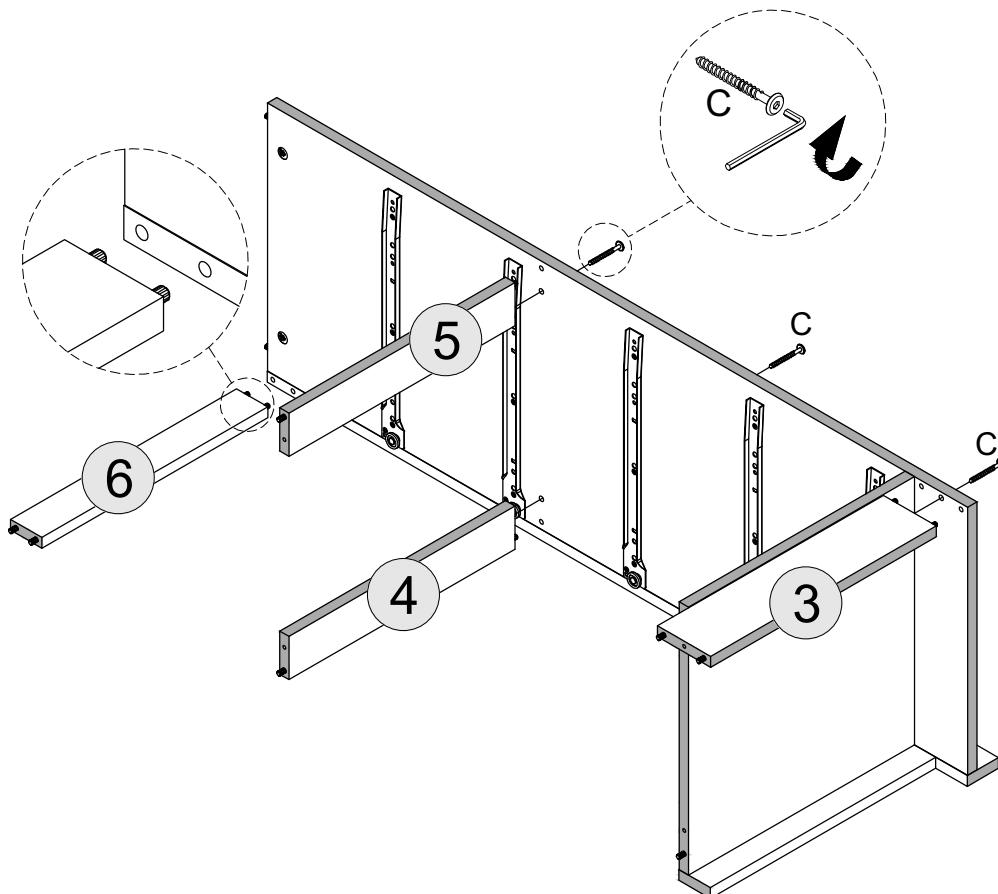

# STEP 7

PARTS REQUIRED

7 - SIDE PANEL - RIGHT x1

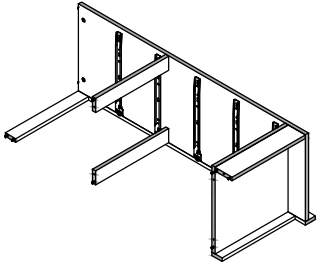

HARDWARE REQUIRED

C  05

TOOLS REQUIRED

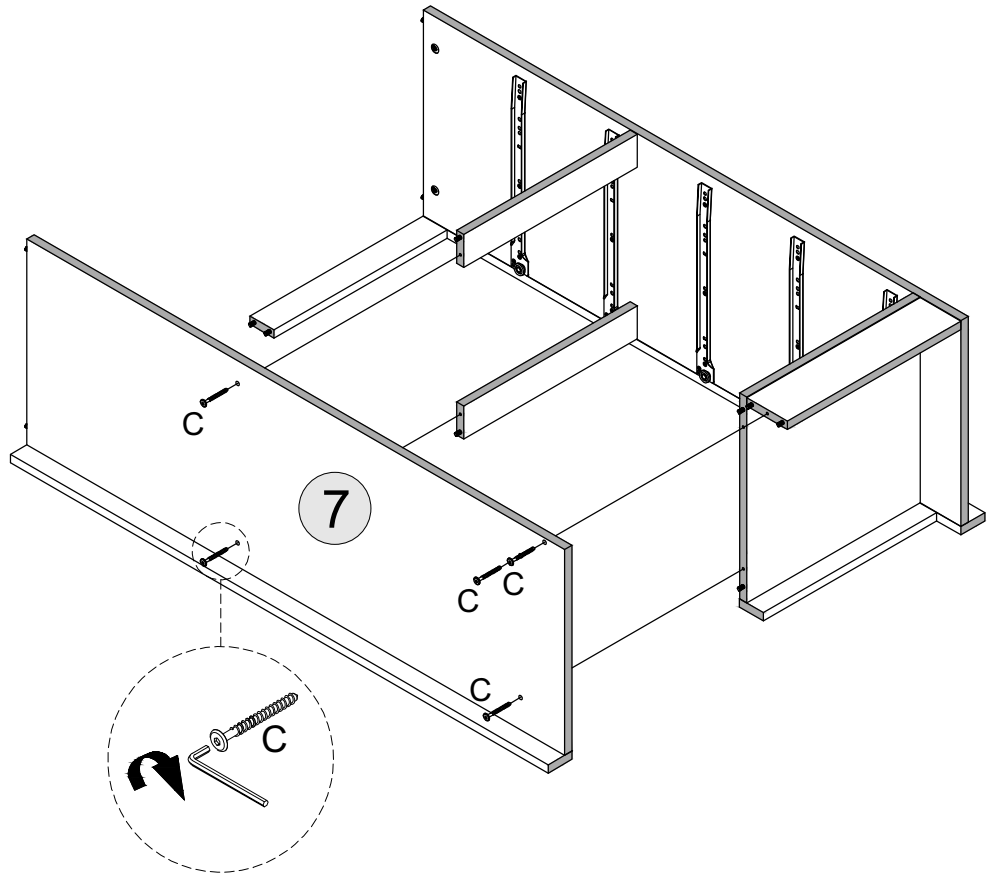

# STEP 8

PARTS REQUIRED

8 - TOP PANEL x1

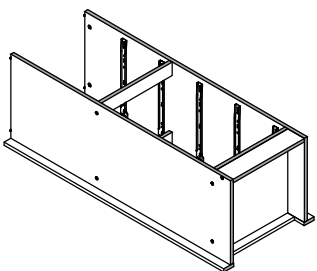

HARDWARE REQUIRED

TOOLS REQUIRED

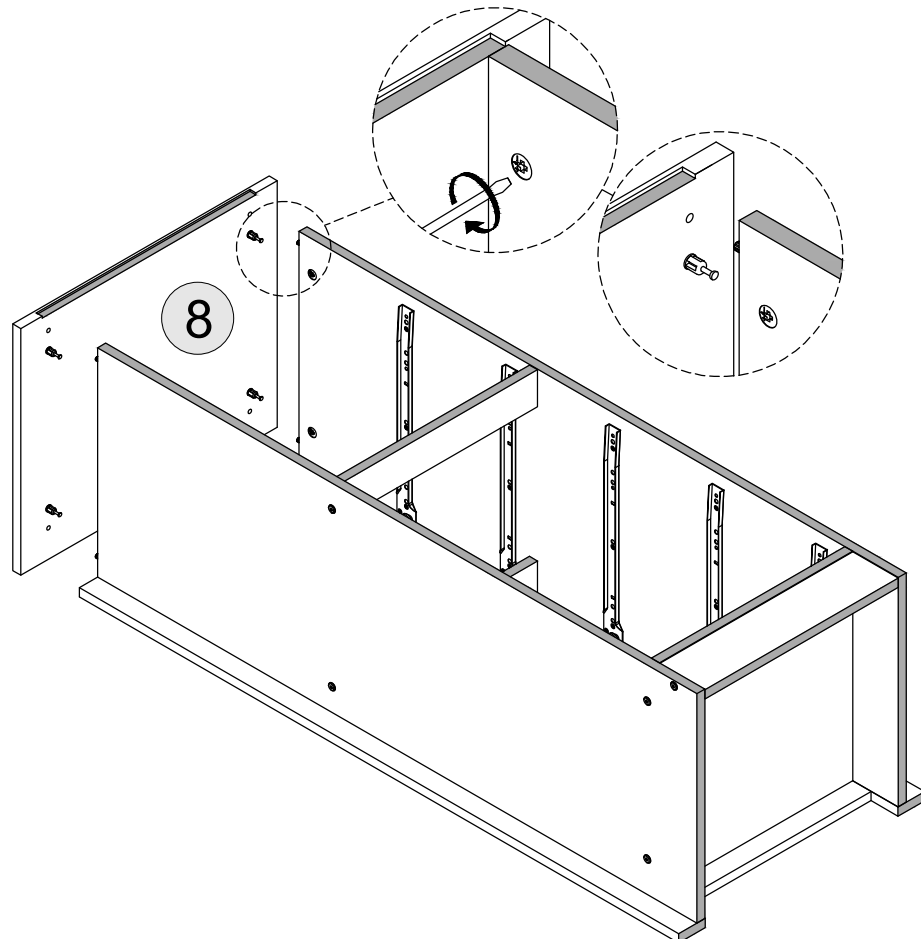
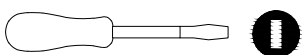

# STEP 9

## PARTS REQUIRED

9 - BACK PANEL x1

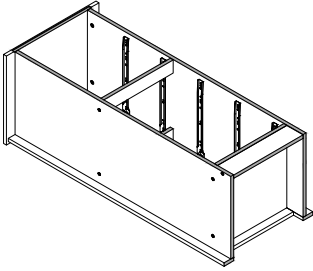

## HARDWARE REQUIRED

D  04

E  26

F  04

## TOOLS REQUIRED

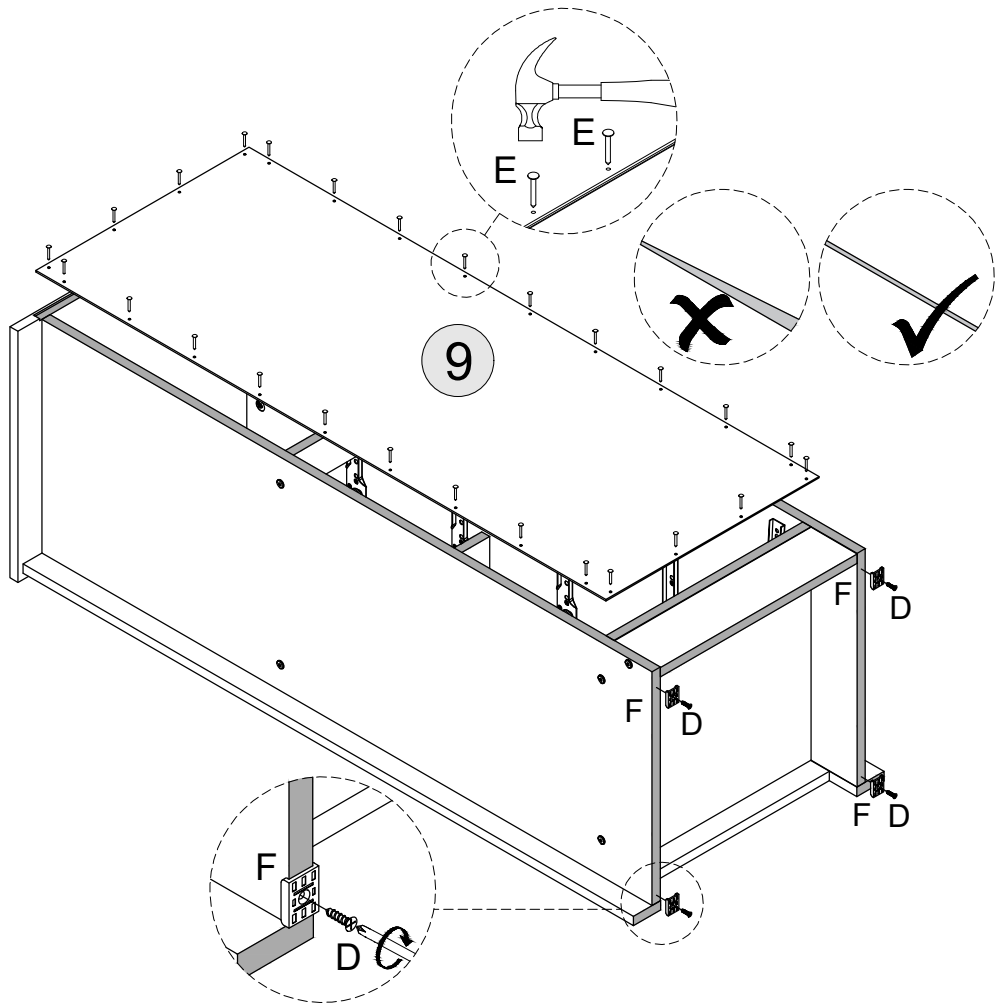
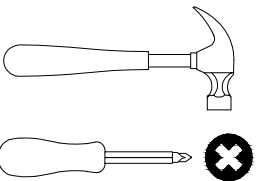

# STEP 10

## PARTS REQUIRED

10 - DRAWER BACK x5

11 - DRAWER SIDE-LEFT x5

12 - DRAWER SIDE-RIGHT x5

13 - DRAWER FRONT x5

## HARDWARE REQUIRED

A  40

B  10

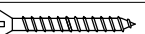
J  10

## TOOLS REQUIRED

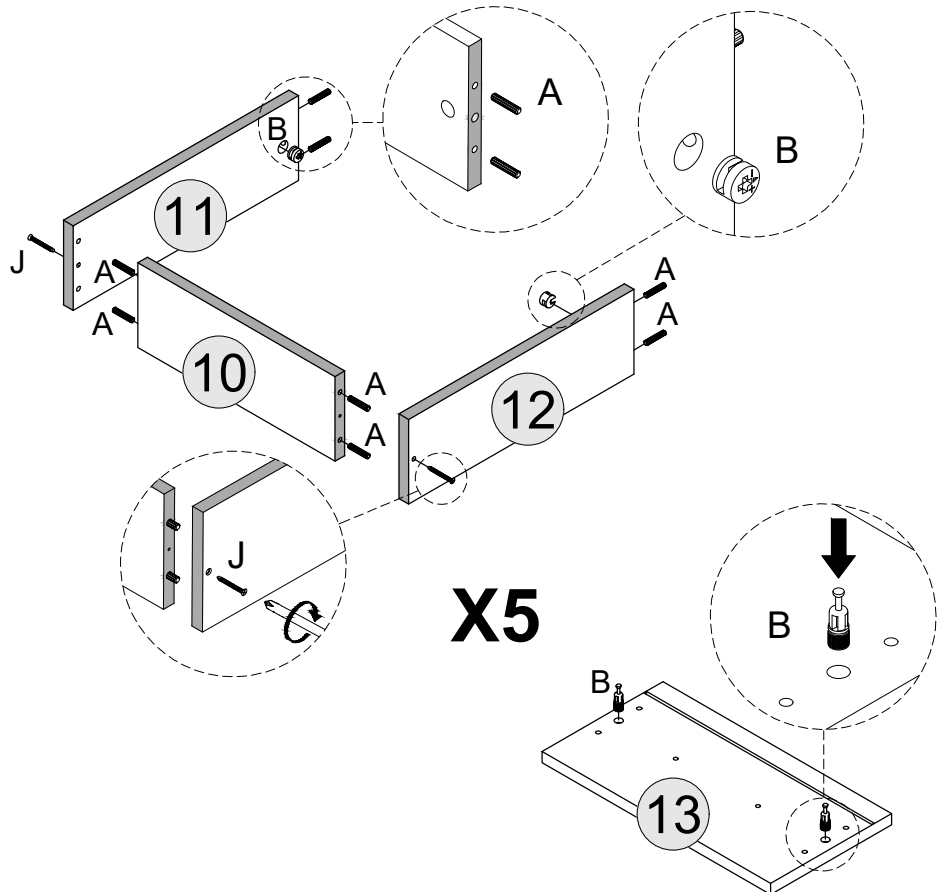
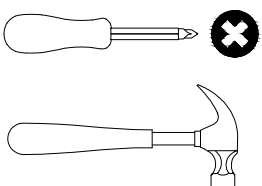



# STEP 11

PARTS REQUIRED

13 - DRAWER FRONT x5

14 - DRAWER BASE x5

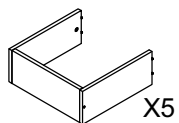

HARDWARE REQUIRED

G  20

H  05

K  10

TOOLS REQUIRED

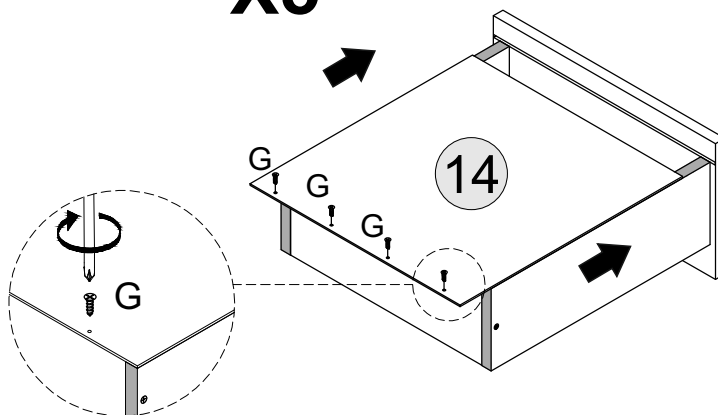
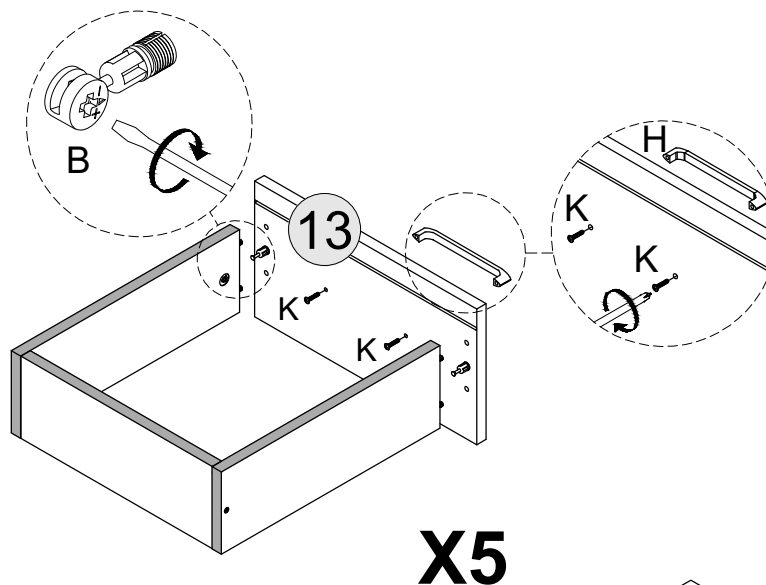
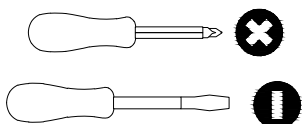

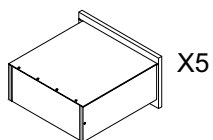

# STEP 12

PARTS REQUIRED



HARDWARE REQUIRED

D  30

M  10

TOOLS REQUIRED

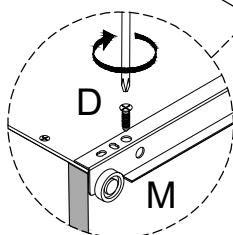
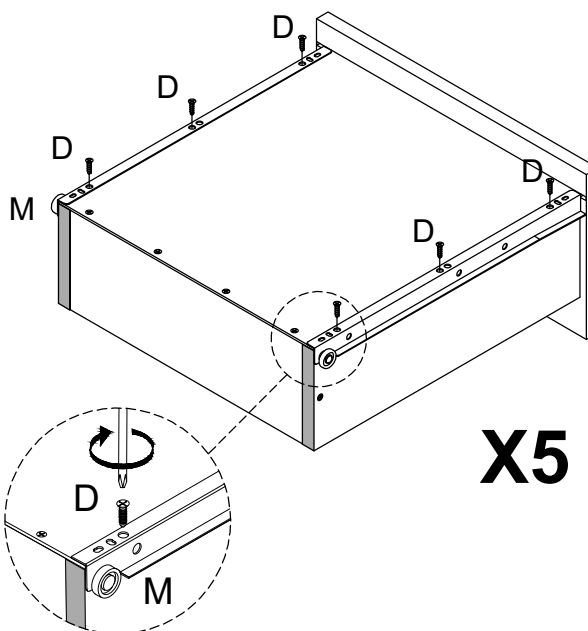
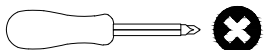

# STEP 13

PARTS REQUIRED

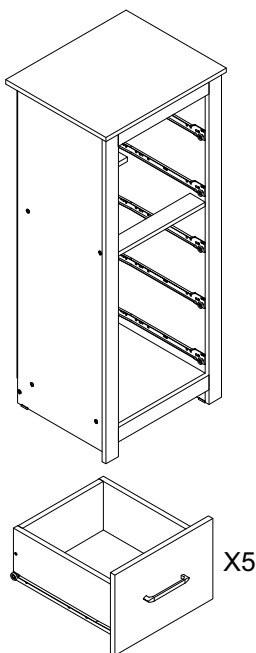

HARDWARE REQUIRED

TOOLS REQUIRED

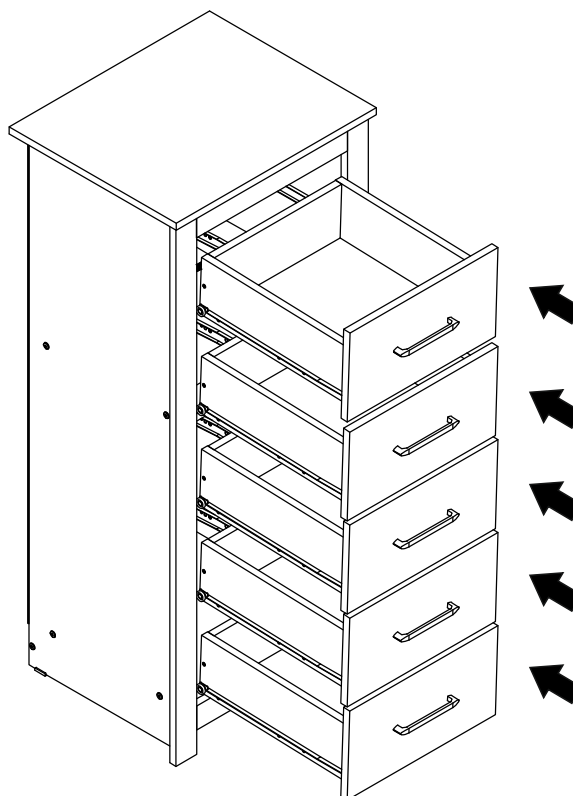

# STEP 14

PART REQUIRED

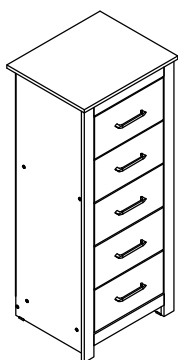

HARDWARE REQUIRED

N		02
O		02

TOOLS REQUIRED

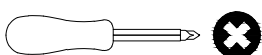

## WARNING

Serious or fatal injuries can occur from furniture tipping over. To prevent the furniture from tipping over we recommend that it is permanently fixed to the wall.

Wall fixings are not supplied with this product as different wall materials require different types of fixing devices. Please make sure you use fixings suitable for the walls in your home.

