

WHITE / OAK EFFECT PORTLAND 2 DRAWER BEDSIDE ASSEMBLY INSTRUCTIONS

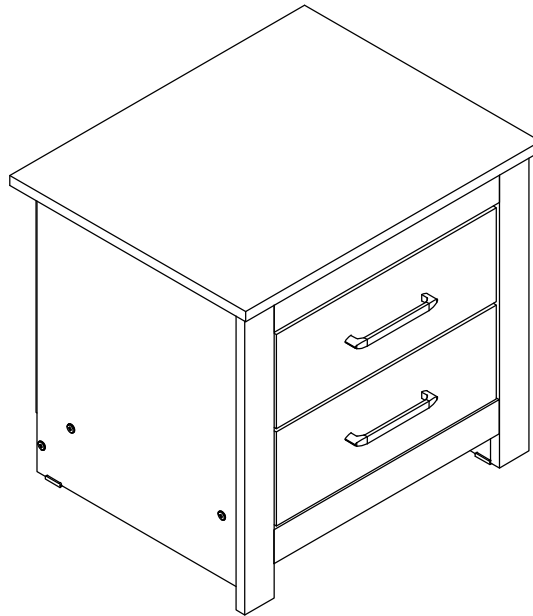
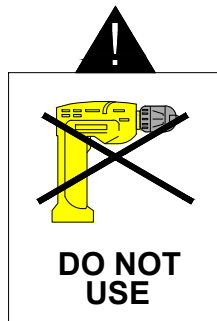

IMPORTANT FOR DOMESTIC USE ONLY PLEASE READ BEFORE YOU CONTINUE FURTHER

THE PRODUCT YOU HAVE PURCHASED WILL GIVE YOU MANY YEARS OF SERVICE IF YOU FOLLOW THE GUIDELINES FOR ITS SAFE ASSEMBLY AND PERIODIC MAINTENANCE AND CLEANING.

ASSEMBLE ON A SOFT CLEAN SURFACE.

DO NOT USE ANY TOOLS OTHER THAN THOSE SHOWN.

ANY SPANNERS OR ALLEN KEYS REQUIRED ARE INCLUDED WITH THE FITTINGS KIT.

DO NOT FOR ANY REASON USE A POWER TOOL TO ASSEMBLE THIS PRODUCT. ITS USE WILL INVALIDATE ANY CLAIM YOU MAY HAVE AND COULD MAKE THIS PRODUCT UNSAFE.

DEPENDING ON THE AMOUNT OF USE THIS PRODUCT RECEIVES IT MAY BE NECESSARY TO TIGHTEN UP THE FIXINGS FROM TIME TO TIME. THIS IS COMPLETELY NORMAL FOR ANY FLAT PACK FURNITURE. DO NOT OVERTIGHTEN FIXING.

FOR CLEANING, YOU MAY USE A DAMP CLOTH (NOT WET) DO NOT USE POLISH, DETERGENT OR CHEMICAL CLEANERS.



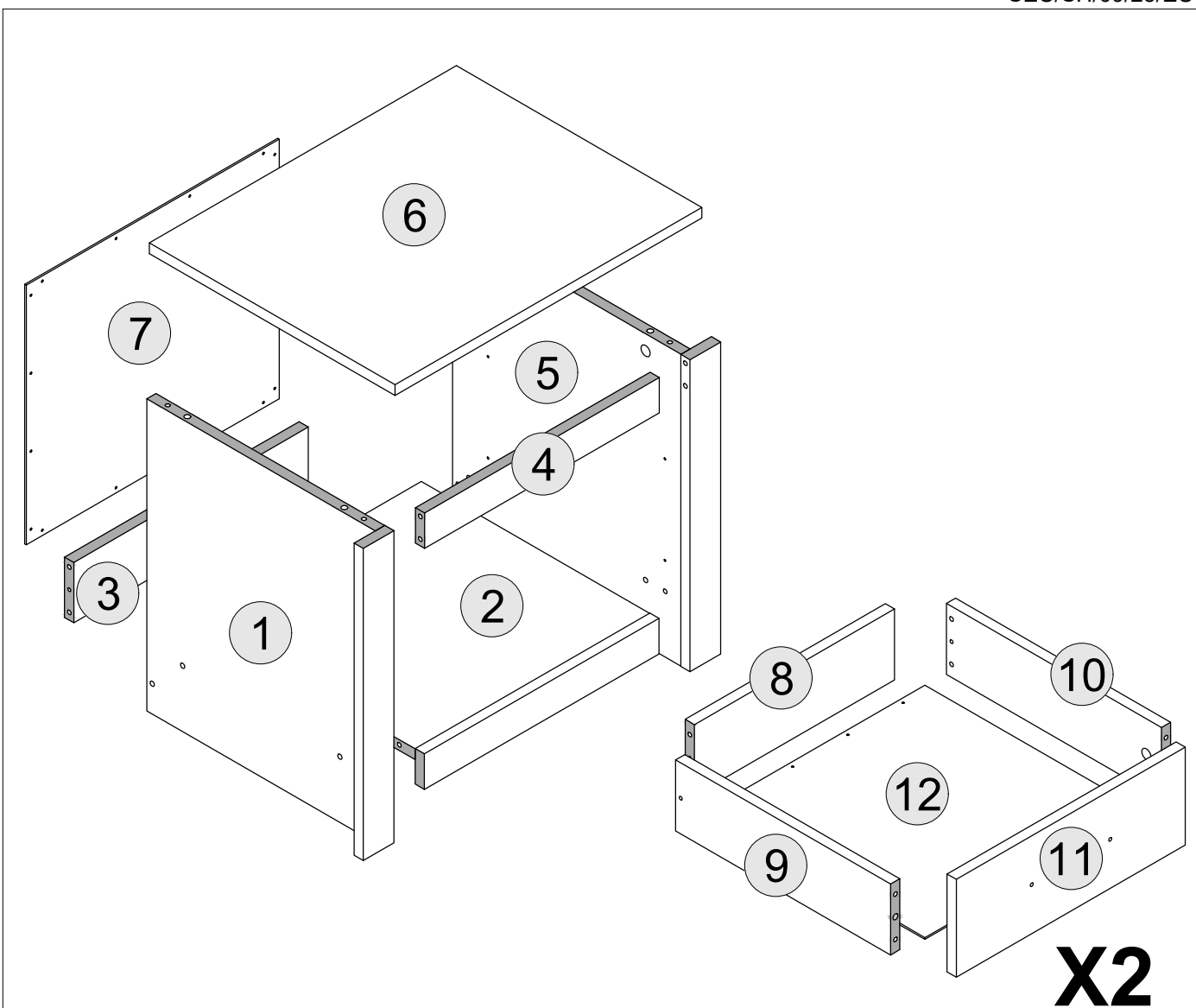







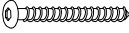

THE SURFACE OF THIS ITEM IS NOT HEAT RESISTANT. ALWAYS USE A PLACE MAT UNDER HOT OR COLD ITEMS TO PREVENT MARKING.

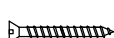

PART LIST

Part Number	Part Code	Part Description	Quantity	Carton
1	100-103-098-EU1-01	Side Panel - Left	1	1/1
2	100-103-098-EU1-02	Bottom Panel	1	1/1
3	100-103-098-EU1-03	Base Apron	1	1/1
4	100-103-098-EU1-04	Top Frame	1	1/1
5	100-103-098-EU1-05	Side Panel - Right	1	1/1
6	100-103-098-EU1-06	Top Panel	1	1/1
7	100-103-098-EU1-07	Back Panel	1	1/1
8	100-103-098-EU1-08	Drawer Back	2	1/1
9	100-103-098-EU1-09	Drawer Side - Left	2	1/1
10	100-103-098-EU1-10	Drawer Side - Right	2	1/1
11	100-103-098-EU1-11	Drawer Front	2	1/1
12	100-103-098-EU1-12	Drawer Base	2	1/1

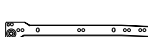
HARDWARE LIST

A		DOWEL 6 X 30MM	32 PCS
B		CAM BOLT + CAM NUT	8 SETS
C		BOLT M6 X 50MM	6 PCS
D		SCREW M3.5 X 16MM	16 PCS
E		TACK	16 PCS
F		PLASTIC FOOT	4 PCS
G		SCREW M3.5 X 12MM	24 PCS
H		HANDLE	2 PCS
I		ALLEN KEY	1 PC
J		SCREW M4 X 38MM	4 PCS
K		HANDLE SCREW 20MM	4 PCS
L		DRAWER RUNNER A - L/R	4 PCS
M		DRAWER RUNNER B - L/R	4 PCS

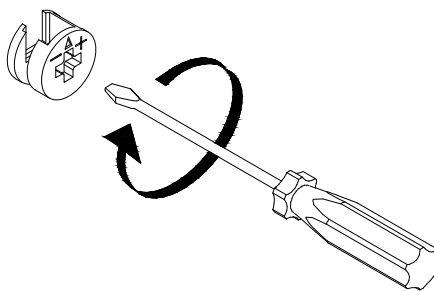

(SCREWDRIVER NOT PROVIDED)

USE A FLAT HEAD SCREWDRIVER TO TIGHTEN THE CAM NUTS. A QUARTER TURN CLOCKWISE IS ALL THAT IS NEEDED.

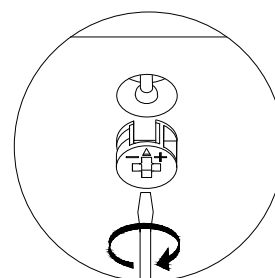
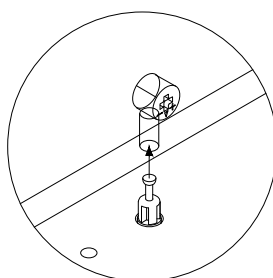
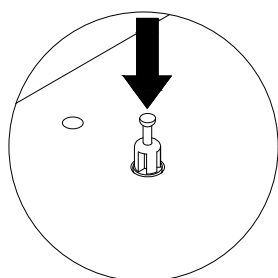

STEP 1 - PUSH CAM BOLT INTO INSERT

STEP 2 - ALIGN THE CAM BOLT WITH THE HOLE AND PUSH TOGETHER UNTIL FLUSH. (MAKE SURE THE ARROW OF THE CAM LOCK IS POINTING TOWARD ON THE EDGE OF THE PANEL.)



STEP 3 - THE HEAD OF THE BOLT GOES INTO THE WIDE MOUTH OF THE CAM LOCK. YOU THEN TURN THE LOCK SO THE NARROW PART CLOSES OVER THE BOLT.

STEP 1

PARTS REQUIRED

1 - SIDE PANEL - LEFT x1

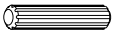
HARDWARE REQUIRED

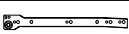
- A  02
- B  02
- G  08
- L  02

TOOLS REQUIRED

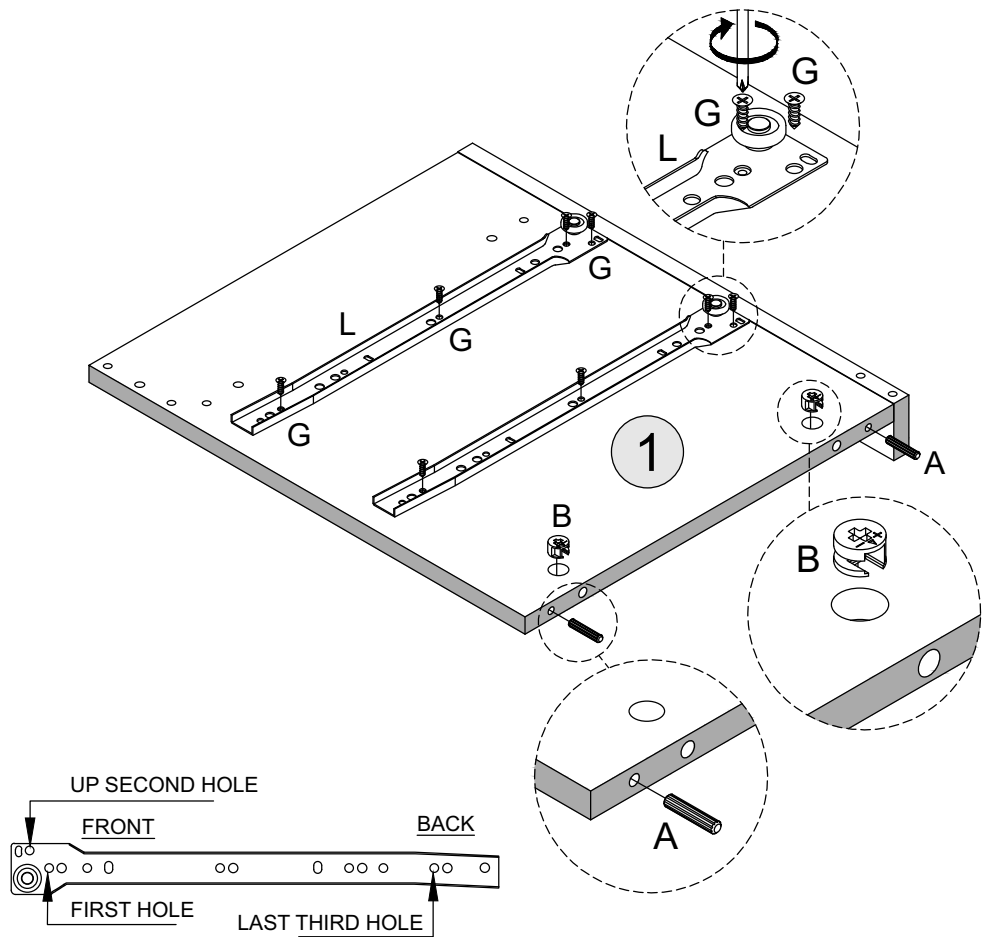
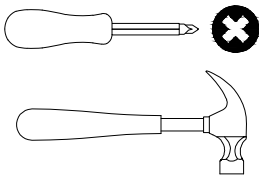



STEP 2

PARTS REQUIRED

5 - SIDE PANEL - RIGHT x1

HARDWARE REQUIRED

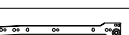
- A  02
- B  02
- G  08
- L  02

TOOLS REQUIRED

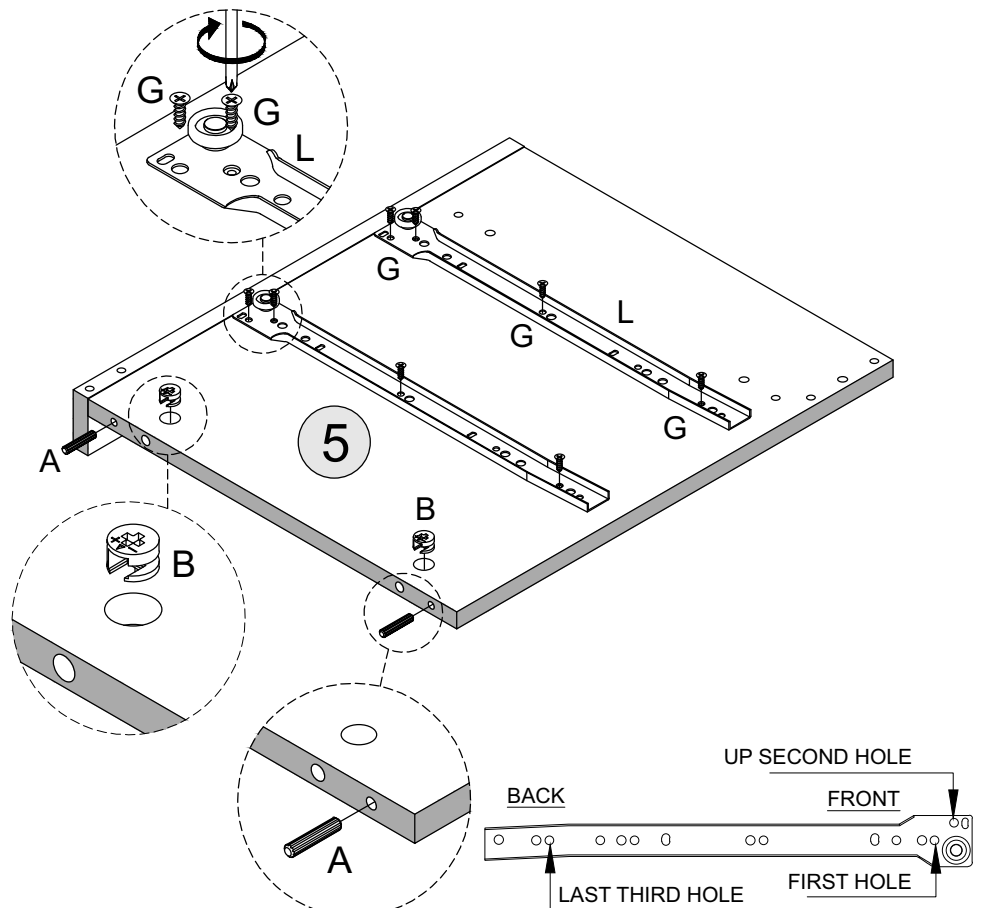
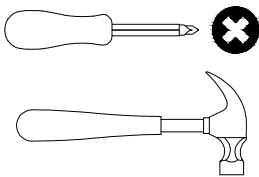

STEP 3

PARTS REQUIRED

2 - BOTTOM PANEL	x1
3 - BASE APRON	x1
4 - TOP FRAME	x1

HARDWARE REQUIRED

A		12
---	---	----

TOOLS REQUIRED

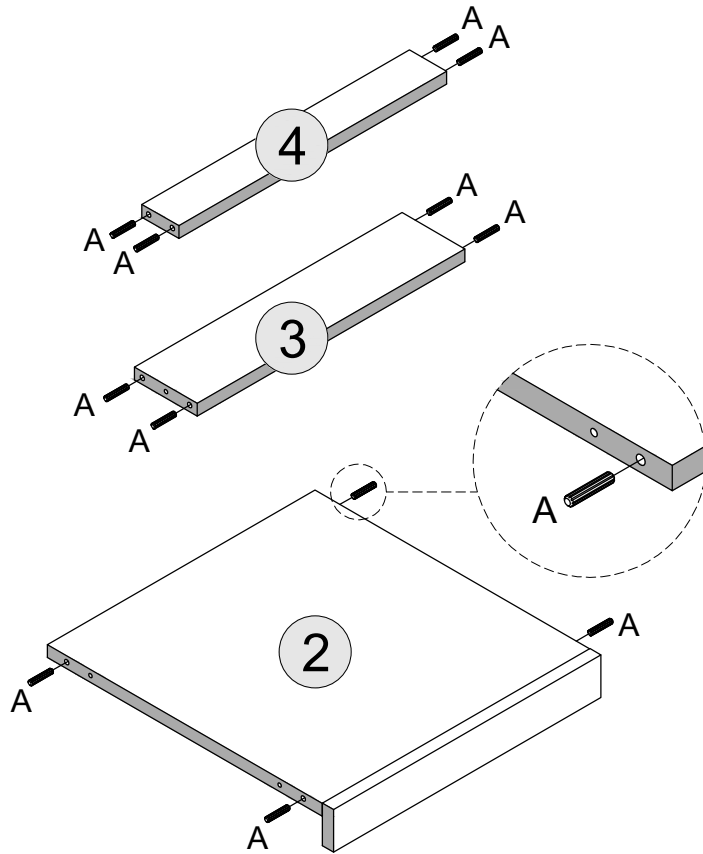
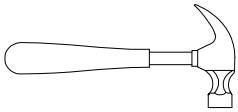

STEP 4

PARTS REQUIRED

6 - TOP PANEL	x1
---------------	----

HARDWARE REQUIRED

B		04
---	---	----

TOOLS REQUIRED

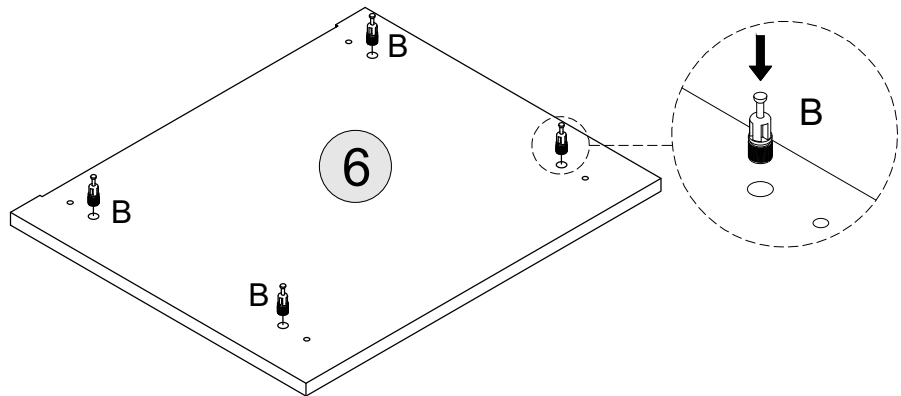

STEP 5

PARTS REQUIRED

1 - SIDE PANEL - LEFT x1

2 - BOTTOM PANEL x1

HARDWARE REQUIRED

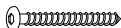
C  02

TOOLS REQUIRED

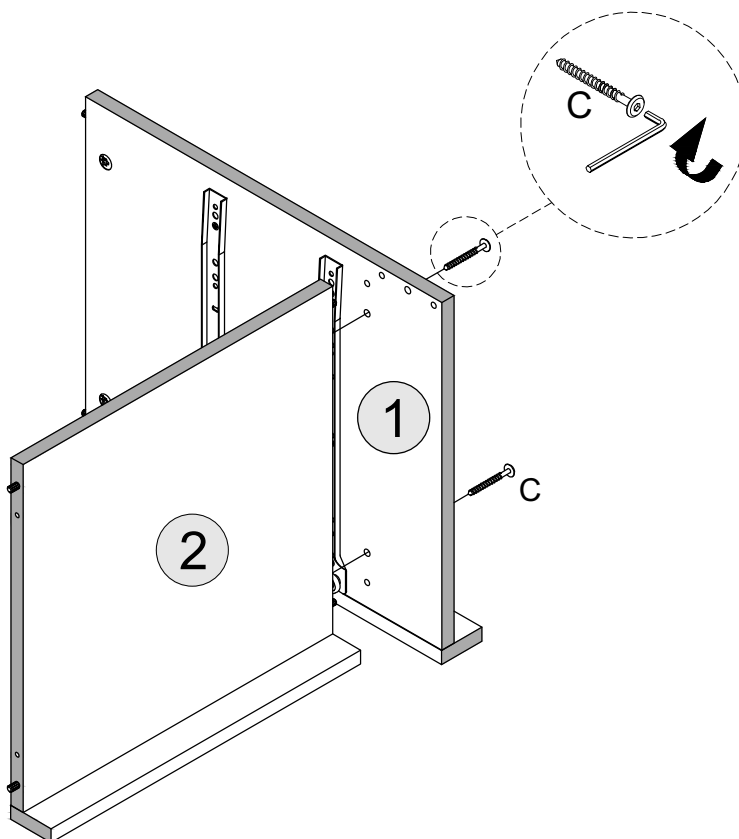

STEP 6

PARTS REQUIRED

3 - BASE APRON x1

4 - TOP FRAME x1

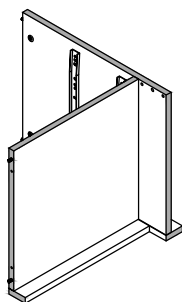

HARDWARE REQUIRED

C  01

TOOLS REQUIRED

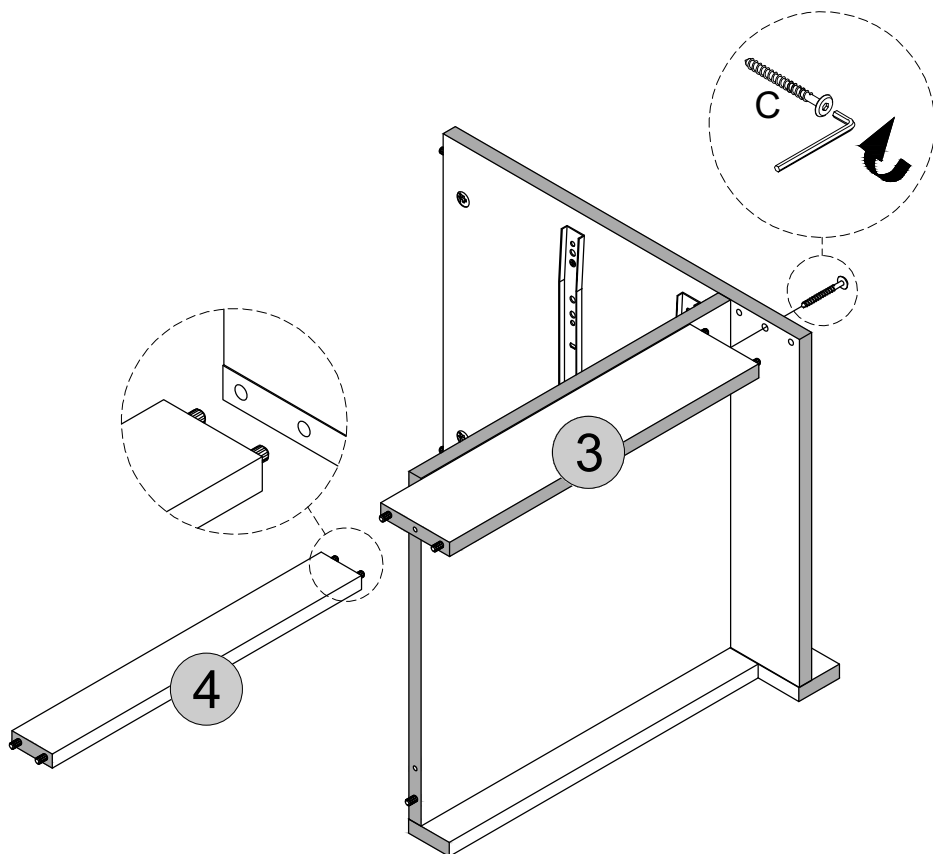

STEP 7

PARTS REQUIRED

5 - SIDE PANEL - RIGHT x1

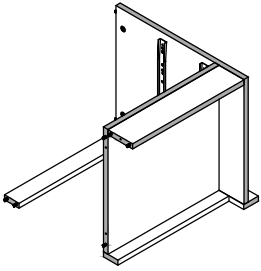

HARDWARE REQUIRED

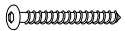
C  03

TOOLS REQUIRED

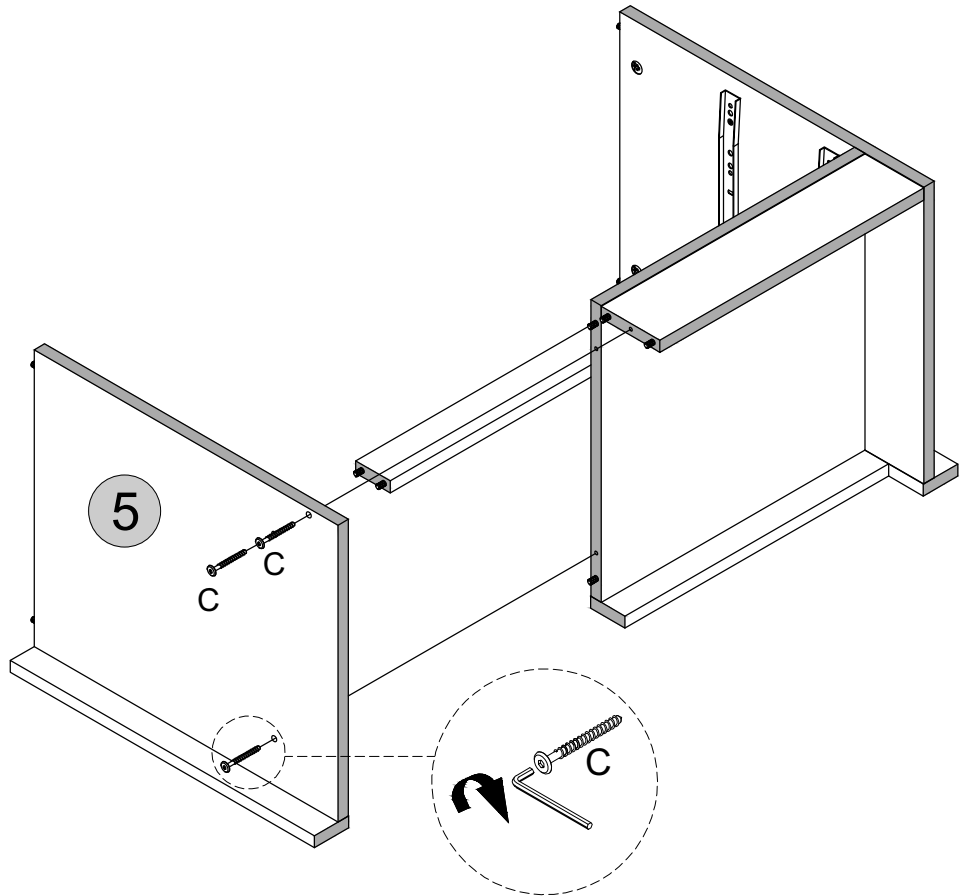

STEP 8

PARTS REQUIRED

6 - TOP PANEL x1

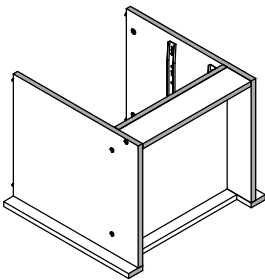

HARDWARE REQUIRED

TOOLS REQUIRED

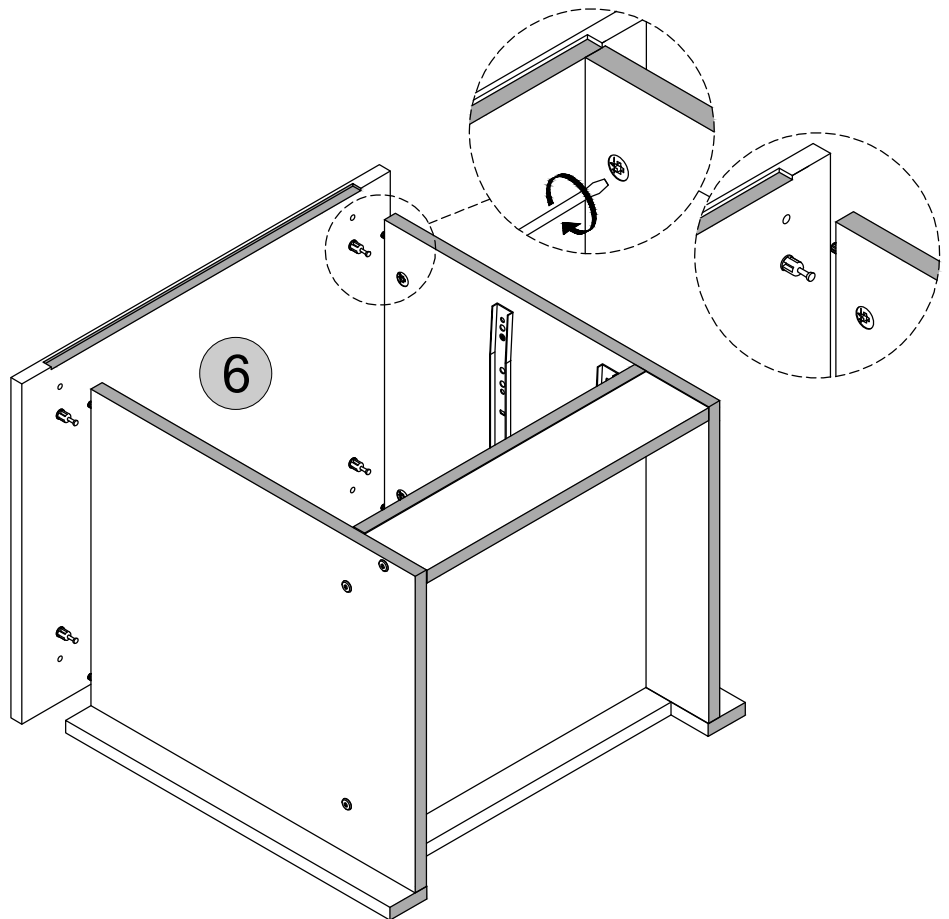
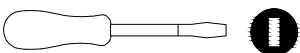

STEP 9

PARTS REQUIRED

7 - BACK PANEL x1

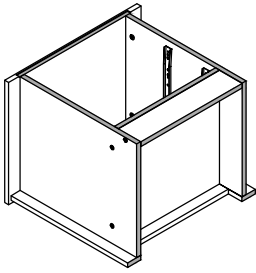

HARDWARE REQUIRED

D  04

E  16

F  04

TOOLS REQUIRED

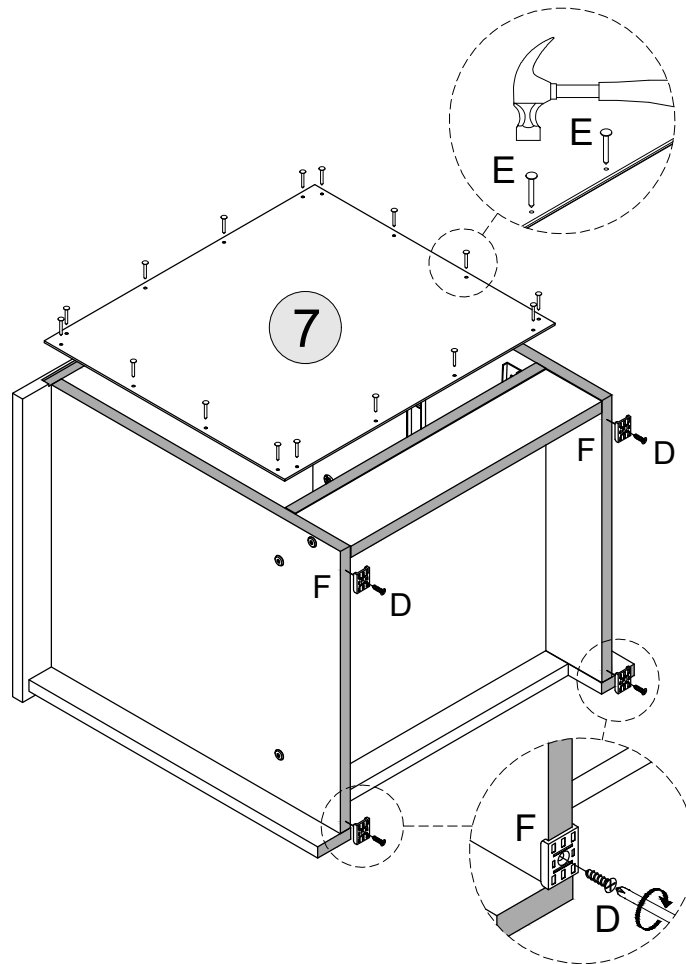
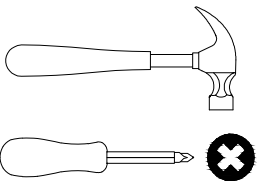

STEP 10

PARTS REQUIRED

8 - DRAWER BACK x2

9 - DRAWER SIDE-LEFT x2

10 - DRAWER SIDE-RIGHT x2

11 - DRAWER FRONT x2

HARDWARE REQUIRED

A  16

B  04

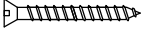
J  04

TOOLS REQUIRED

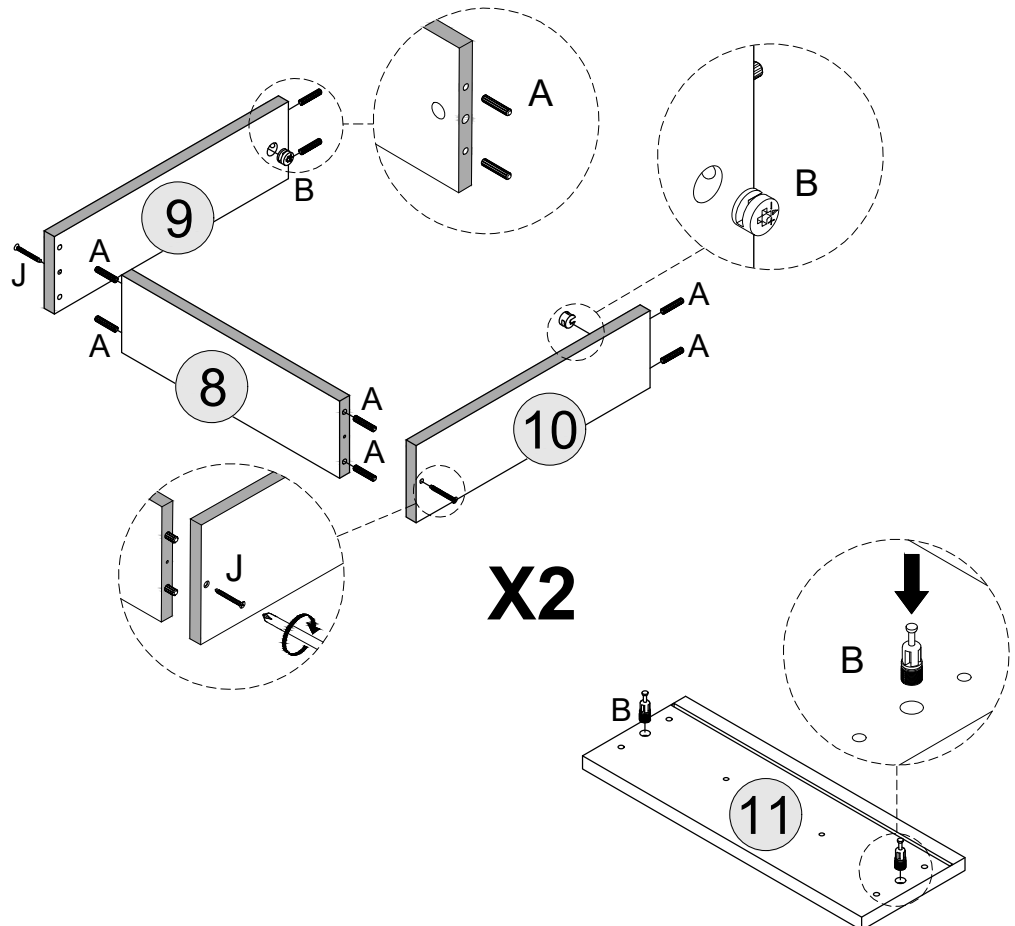
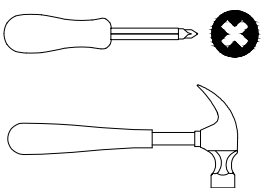

STEP 11

PARTS REQUIRED

11 - DRAWER FRONT x2

12 - DRAWER BASE x2

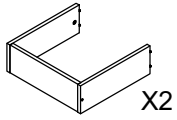

HARDWARE REQUIRED

G  08

H  02

K  04

TOOLS REQUIRED

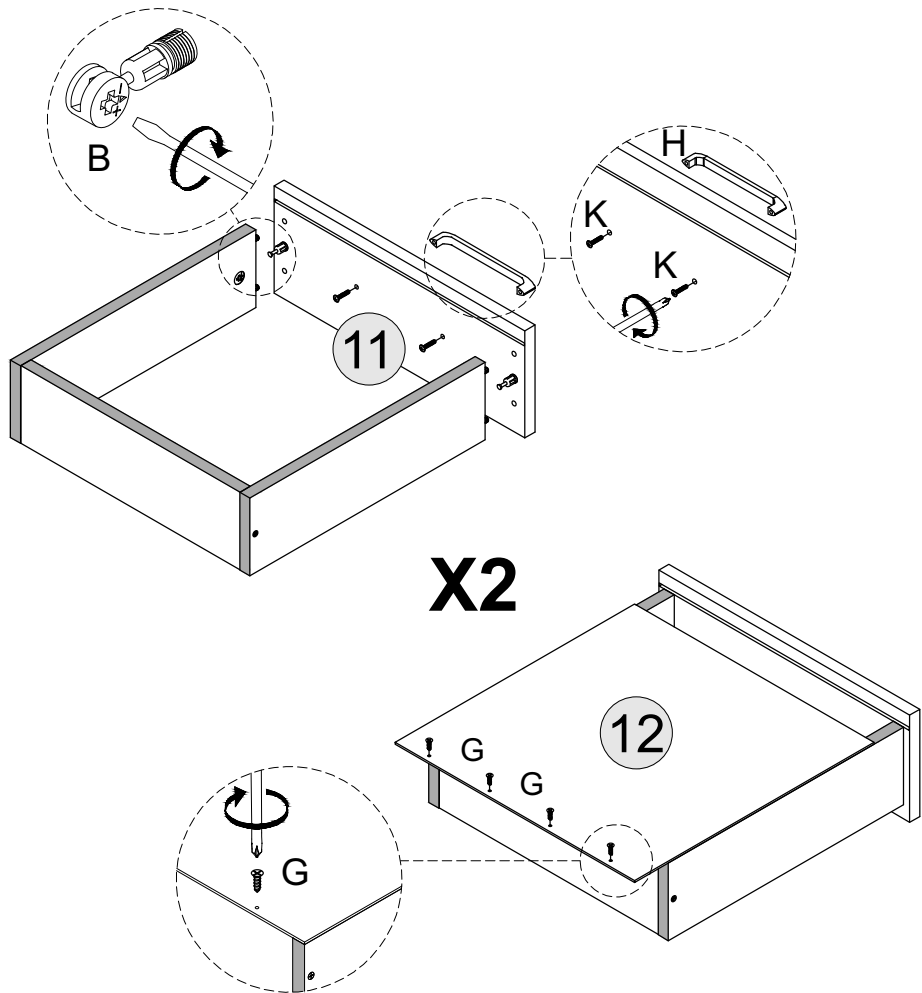
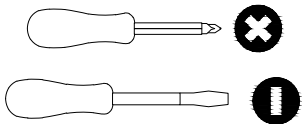

STEP 12

PARTS REQUIRED

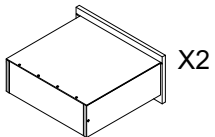

HARDWARE REQUIRED

D  12

M  04

TOOLS REQUIRED

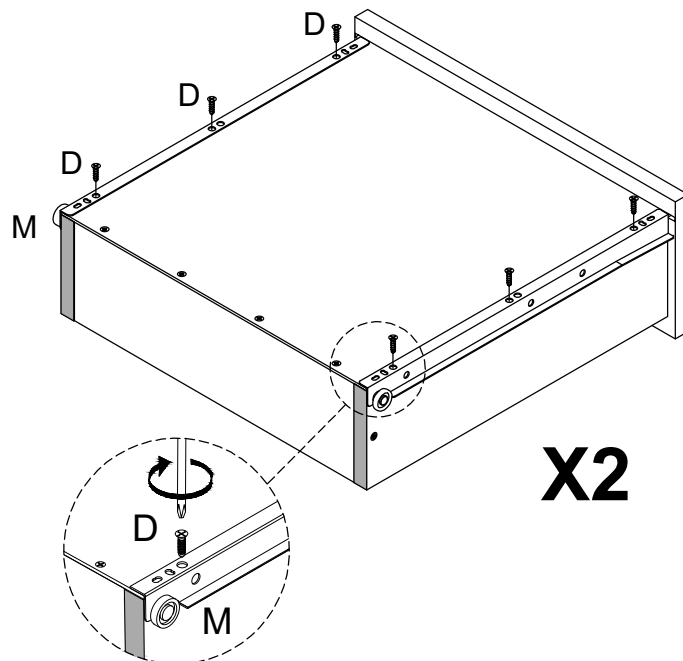
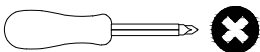

STEP 13

PARTS REQUIRED

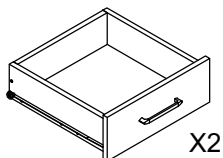
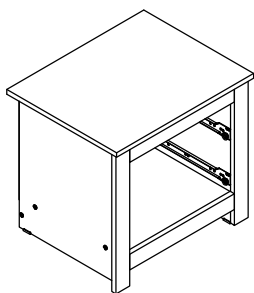

HARDWARE REQUIRED

TOOLS REQUIRED

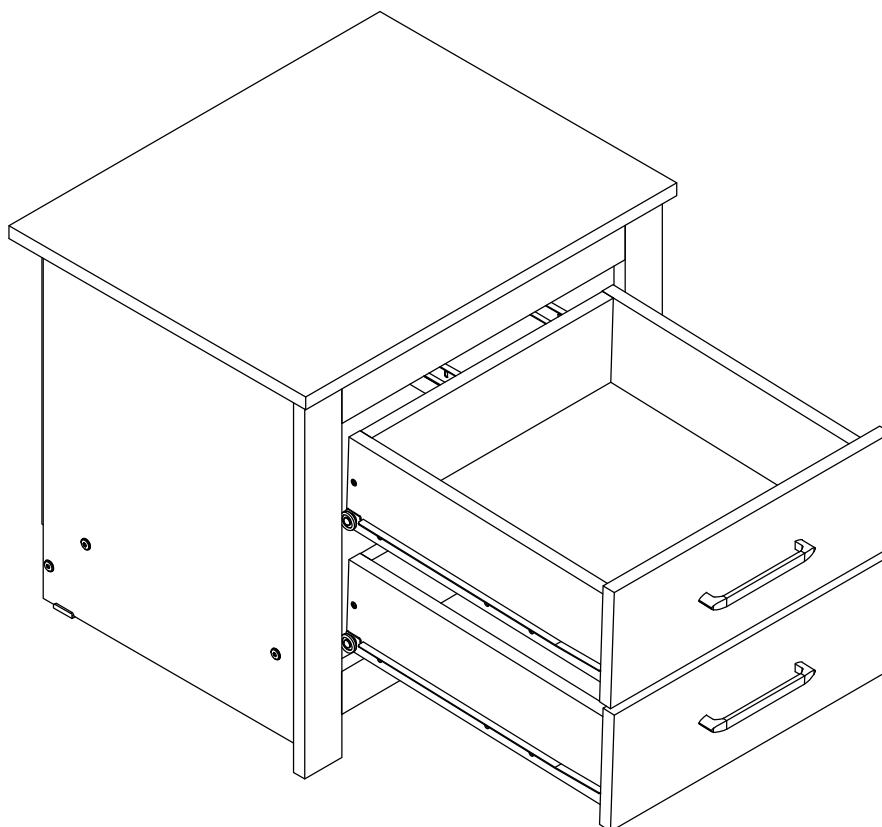

STEP 14

PART REQUIRED

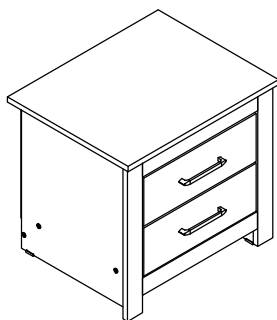

HARDWARE REQUIRED

TOOLS REQUIRED

