

YORK 5' BED ASSEMBLY INSTRUCTIONS

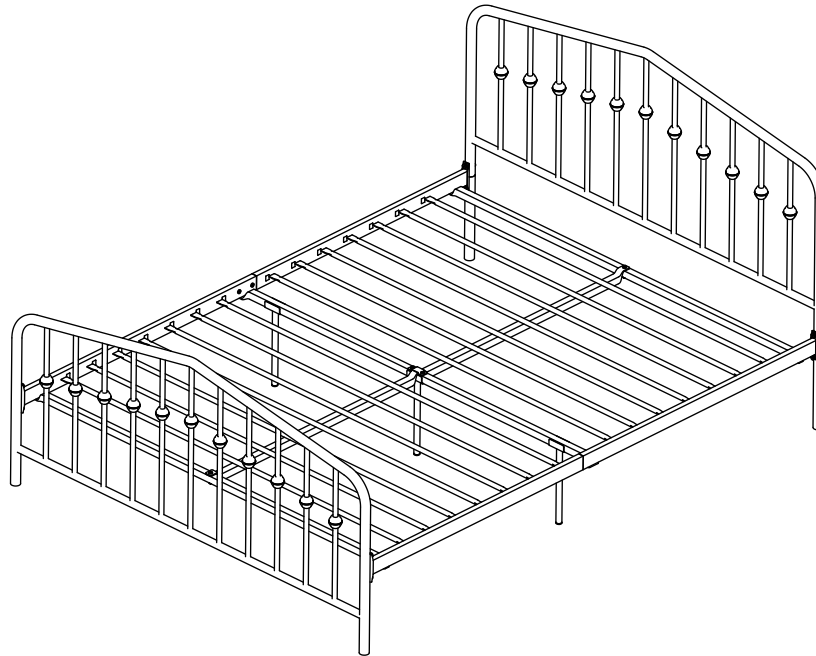

FOR DOMESTIC USE ONLY **IMPORTANT**

PLEASE READ BEFORE YOU CONTINUE FURTHER

THE PRODUCT YOU HAVE PURCHASED WILL GIVE YOU MANY YEARS OF SERVICE IF YOU FOLLOW THE GUIDELINES FOR ITS SAFE ASSEMBLY AND PERIODIC MAINTENANCE AND CLEANING.

DO NOT USE ANY TOOLS OTHER THAN THOSE SHOWN.

ANY SPANNERS OR ALLEN KEYS REQUIRED ARE INCLUDED WITH THE FITTINGS KIT.

DO NOT FOR ANY REASON USE A POWER TOOL TO ASSEMBLE THIS PRODUCT. ITS USE WILL INVALIDATE ANY CLAIM YOU MAY HAVE AND COULD MAKE THIS PRODUCT UNSAFE.

DEPENDING ON THE AMOUNT OF USE THIS PRODUCT RECEIVES IT MAY BE NECESSARY TO TIGHTEN UP THE FIXINGS FROM TIME TO TIME. THIS IS COMPLETELY NORMAL FOR ANY FLAT PACK FURNITURE.



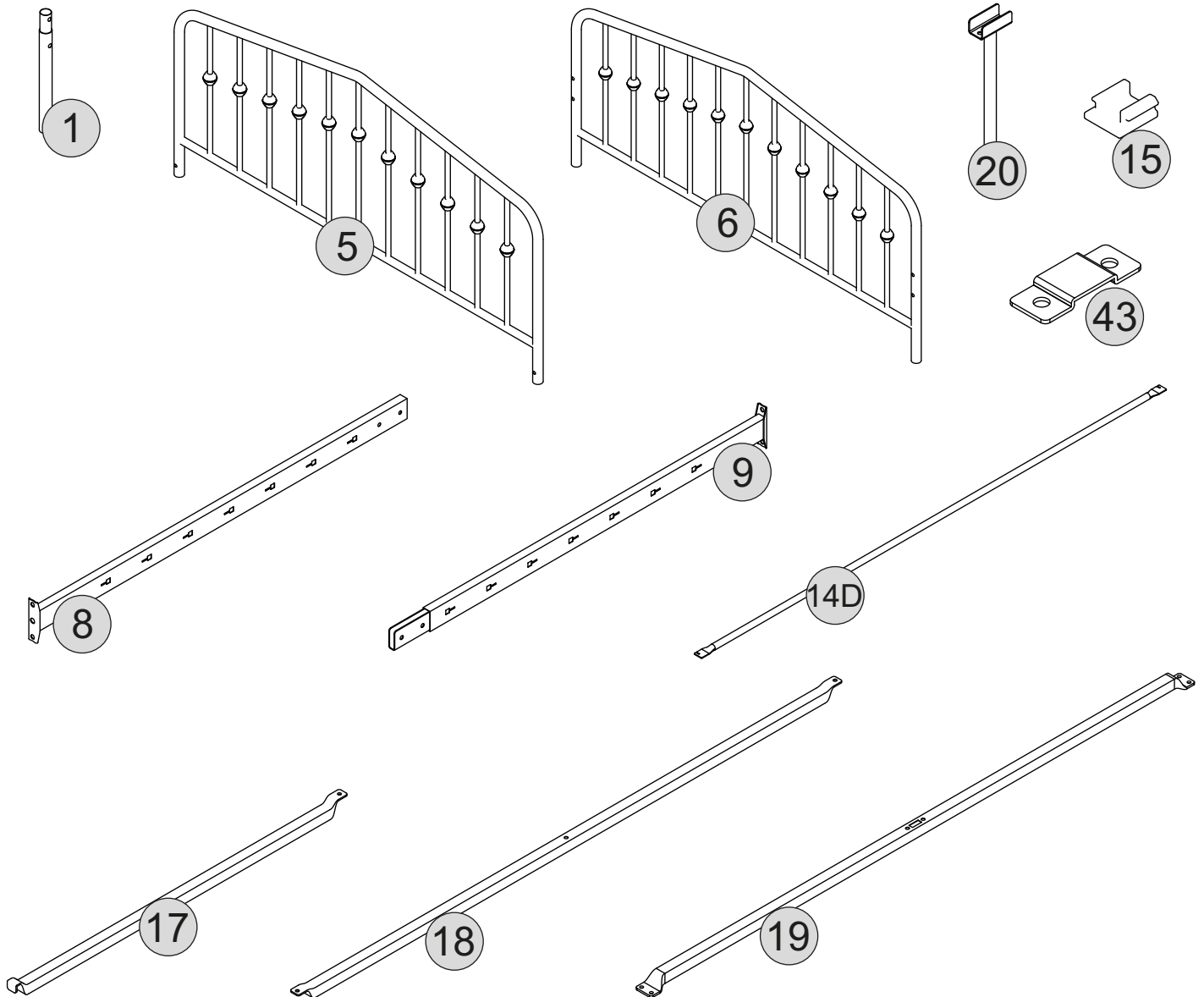



FOR CLEANING YOU MAY USE A DAMP CLOTH (NOT WET) DRY DUSTER AND NORMAL FURNITURE POLISH.

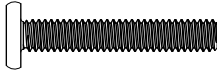
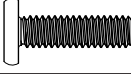
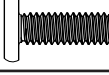
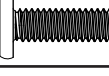

PART LIST

| Part Number | Part Code | Part Description | Quantity | Carton |
|-------------|----------------------|------------------|----------|--------|
| 1 | S200-204-047-XK1-01 | Headboard Post | 2 | 1/1 |
| 5 | S200-204-047-XK1-05 | Headboard | 1 | 1/1 |
| 6 | S200-204-047-XK1-06 | Footboard | 1 | 1/1 |
| 8 | S200-204-047-XK1-08 | Siderail A | 2 | 1/1 |
| 9 | S200-204-047-XK1-09 | Siderail B | 2 | 1/1 |
| 14D | S200-204-047-XK1-14D | Slats | 14 | 1/1 |
| 15 | S200-204-047-XK1-15 | Plastic Plug | 28 | 1/1 |
| 17 | S200-204-047-XK1-17 | Brace | 2 | 1/1 |
| 18 | S200-204-047-XK1-18 | Top/Bottom Brace | 2 | 1/1 |
| 19 | S200-204-047-XK1-19 | Centre Brace | 1 | 1/1 |
| 20 | S200-204-047-XK1-20 | Leg | 3 | 1/1 |
| 43 | S200-204-047-XK1-43 | Bracket | 1 | 1/1 |

HARDWARE LIST

| No | Part Name | | Qty | Carton |
|----|------------------|---|-----|--------|
| A | 38mm M6 Bolt |  | x4 | 1 |
| B | 22mm M6 Bolt |  | x12 | 1 |
| C | 18mm M6 Bolt |  | x6 | 1 |
| D | 22mm M8 Bolt |  | x8 | 1 |
| E | M6 Nut |  | x4 | 1 |
| F | M8 Spring Washer |  | x8 | 1 |
| G | M8 Metal Washer |  | x8 | 1 |
| H | 4mm Allen Key |  | x1 | 1 |
| I | Spanner |  | x1 | 1 |

THE USE OF POWER TOOLS TO ASSEMBLE THIS PRODUCT WILL INVALIDATE ANY CLAIM AND MAY DAMAGE THIS PRODUCT MAKING IT UNSAFE

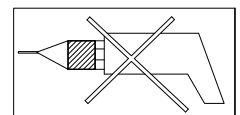

STEP 1

PARTS REQUIRED

1 - HEADBOARD POST x2



5 - HEADBOARD x1

HARDWARE REQUIRED

C  02

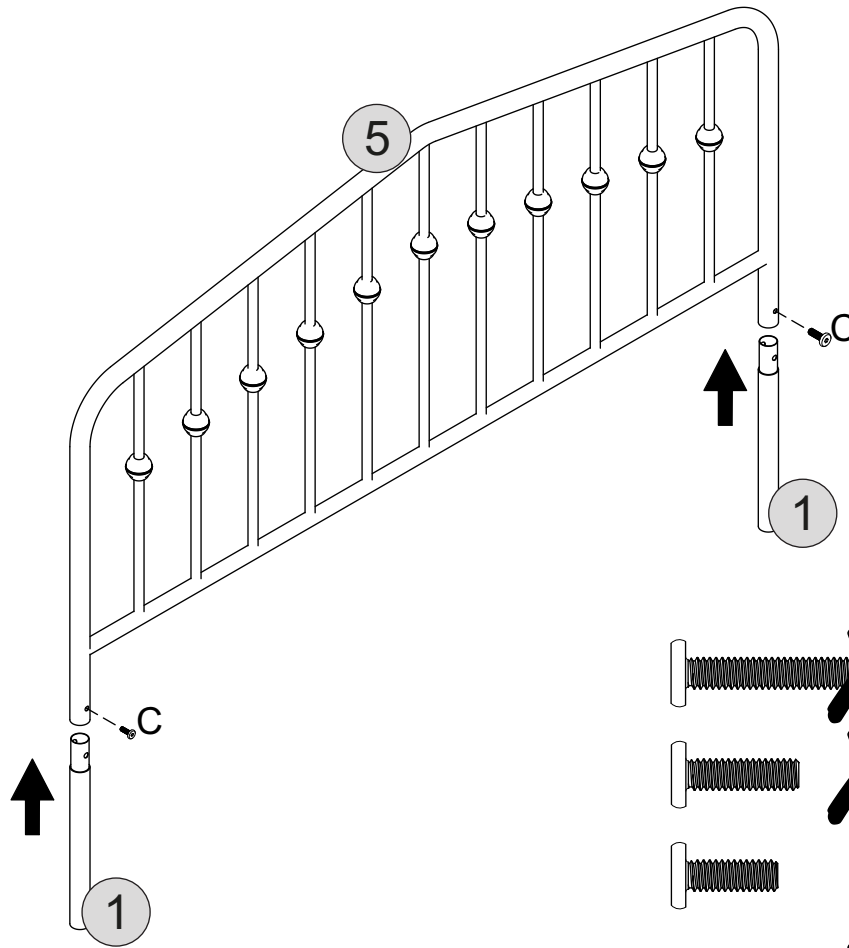
TOOLS REQUIRED

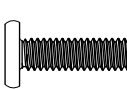
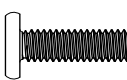
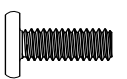

-  ~~X~~ M6x38mm
-  ~~X~~ M6x22mm
-  M6x18mm
-  ~~X~~ M8x22mm

STEP 2

PARTS REQUIRED

8 - SIDERAIL x2





9 - SIDERAIL x2

HARDWARE REQUIRED

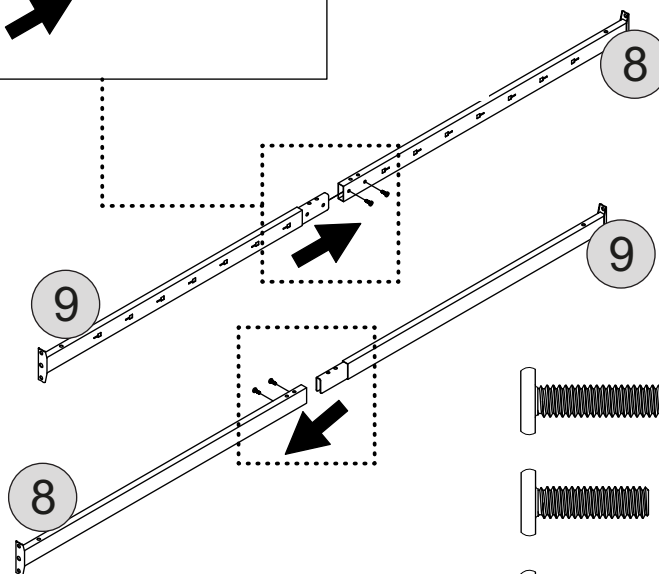
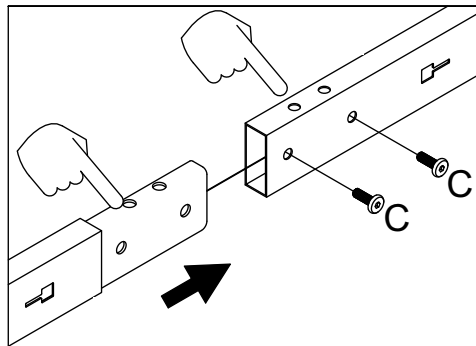
C  04

TOOLS REQUIRED



-  ~~X~~ M6x38mm
-  ~~X~~ M6x22mm
-  M6x18mm
-  ~~X~~ M8x22mm

STEP 3

PARTS REQUIRED

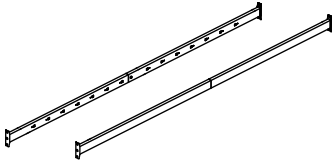

18 - TOP/BOTTOM BRACE x2





19 - CENTRE BRACE x1

HARDWARE REQUIRED

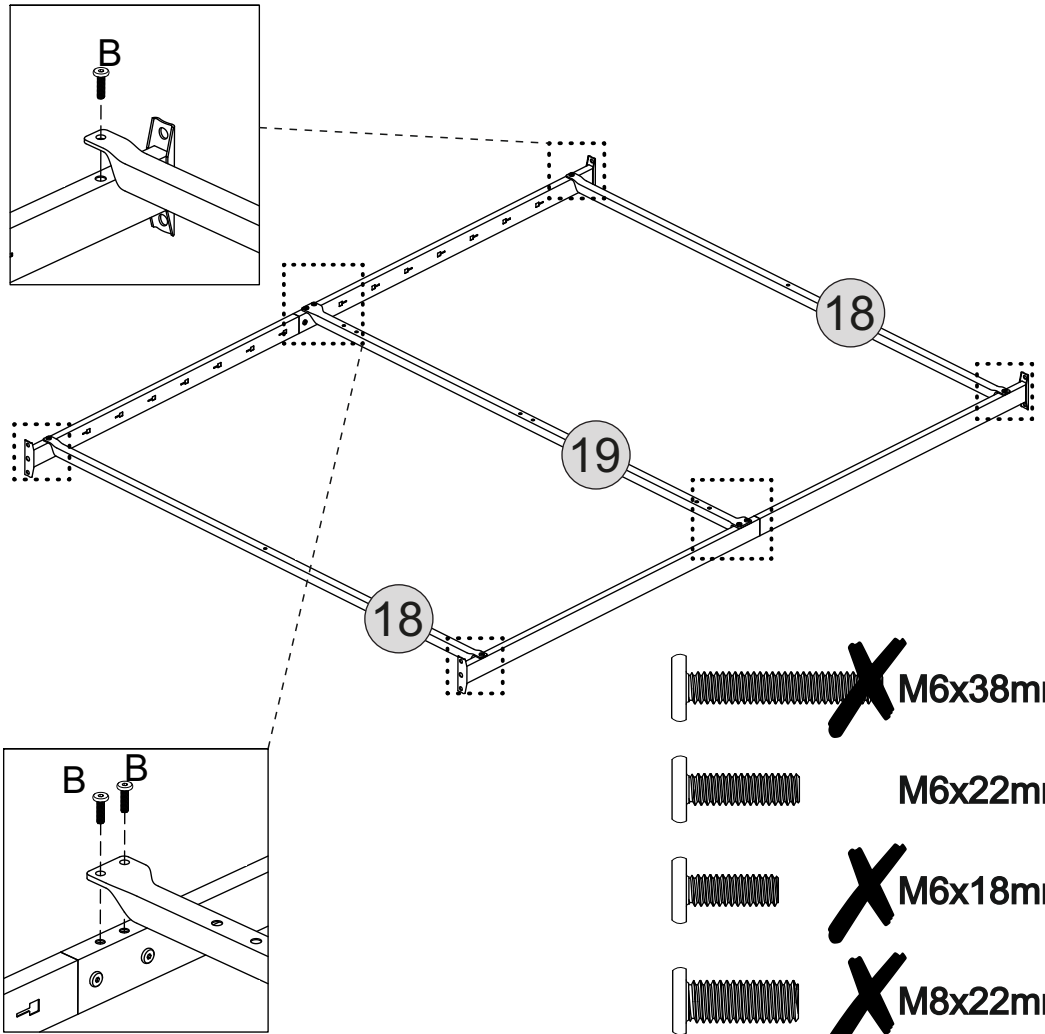

TOOLS REQUIRED



-  ~~X~~ M6x38mm
-  M6x22mm
-  ~~X~~ M6x18mm
-  ~~X~~ M8x22mm

STEP 4

PARTS REQUIRED

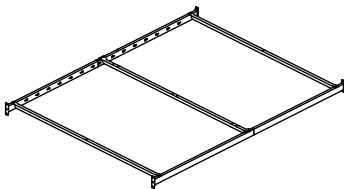



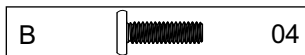

20 - LEG x2

HARDWARE REQUIRED

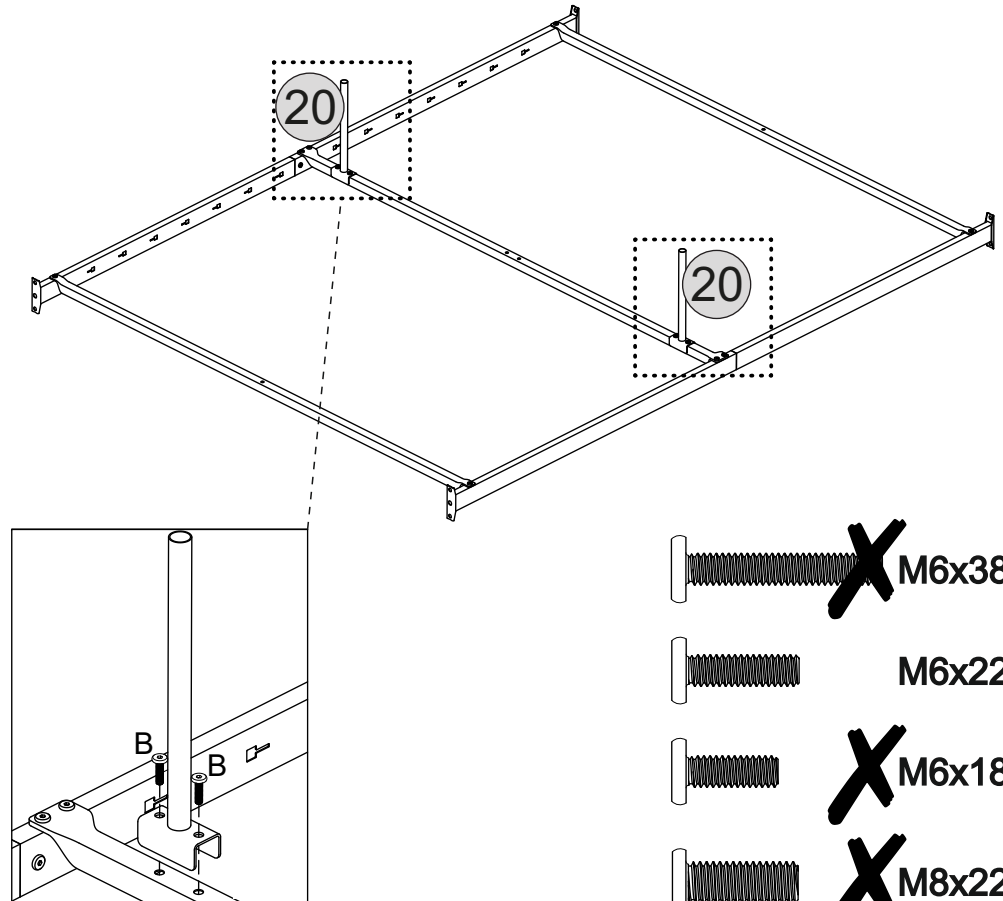

TOOLS REQUIRED



-  ~~X~~ M6x38mm
-  M6x22mm
-  ~~X~~ M6x18mm
-  ~~X~~ M8x22mm

STEP 5

PARTS REQUIRED

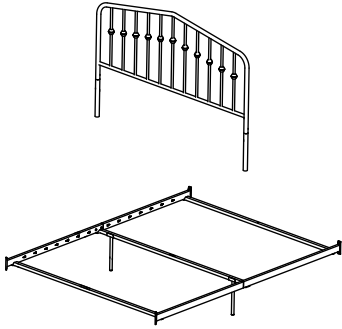

6 - FOOTBOARD x1

HARDWARE REQUIRED

| | | |
|---|--|----|
| D | | 08 |
| F | | 08 |
| G | | 08 |

TOOLS REQUIRED

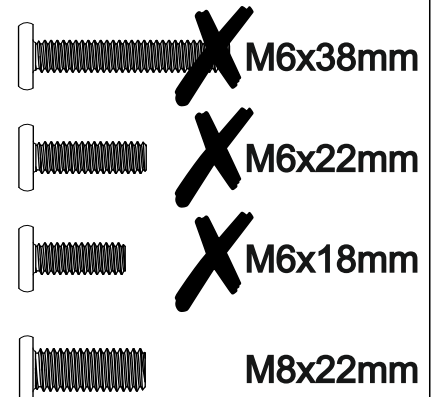
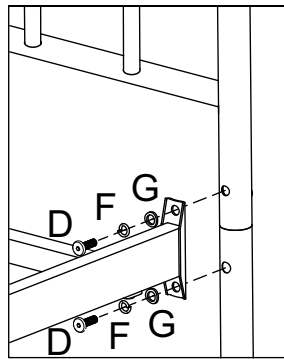
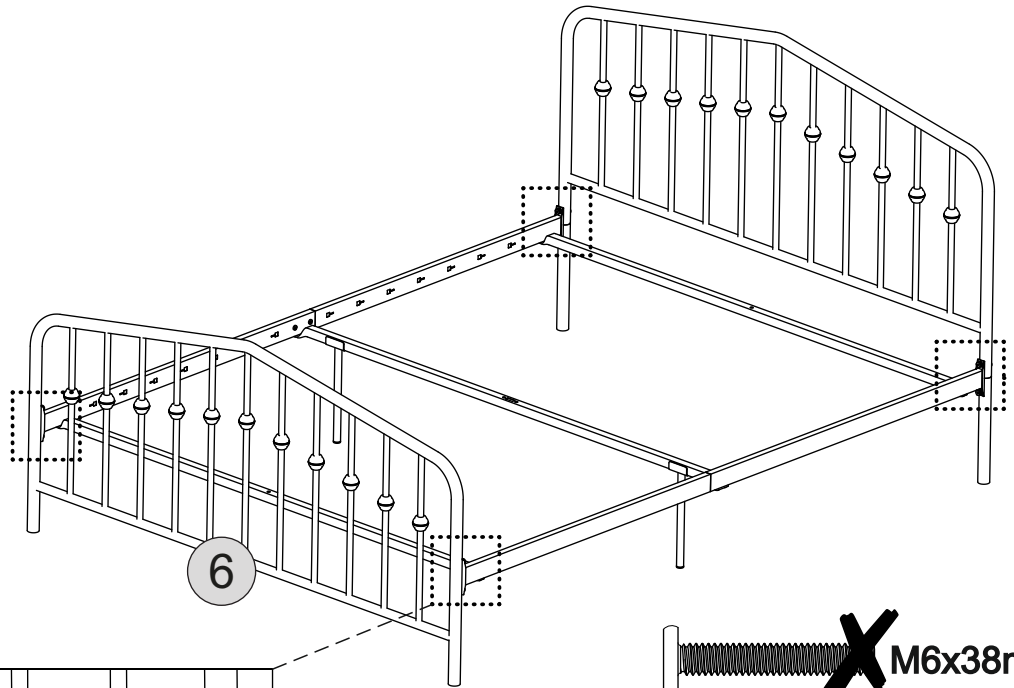
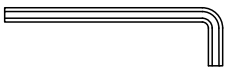

STEP 6

PARTS REQUIRED

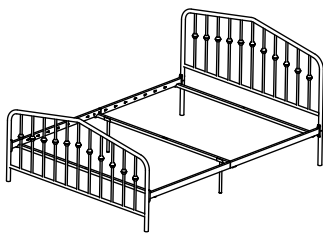

17 - BRACE x2

HARDWARE REQUIRED

| | | |
|---|--|----|
| A | | 02 |
| E | | 02 |

TOOLS REQUIRED

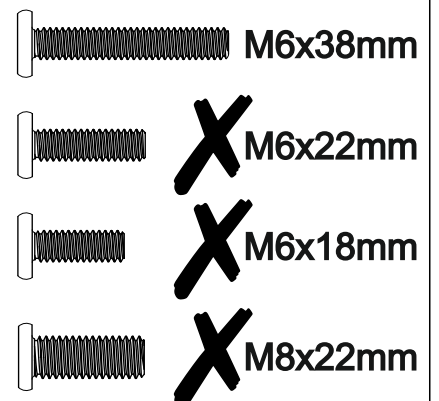
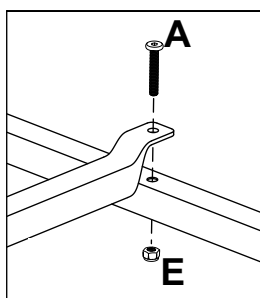
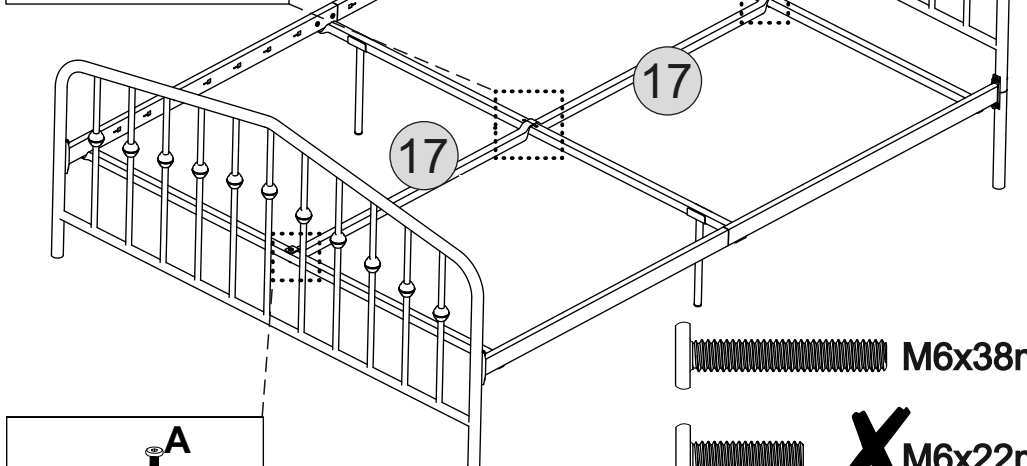
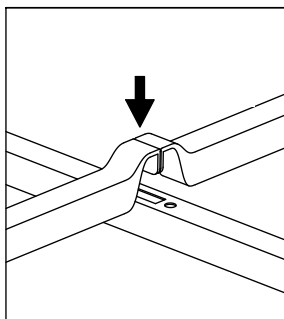
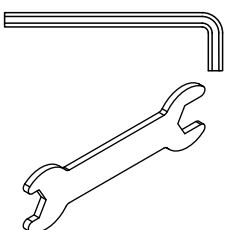

STEP 7

PARTS REQUIRED

20 - LEG x1

43 - BRACKET x1

HARDWARE REQUIRED

A  02

E  02

TOOLS REQUIRED

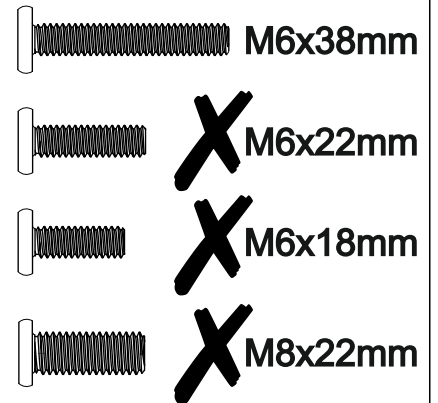
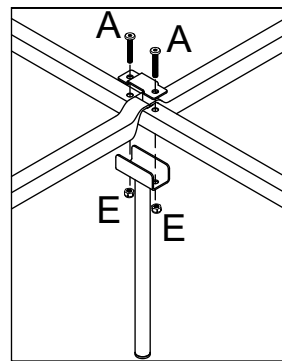
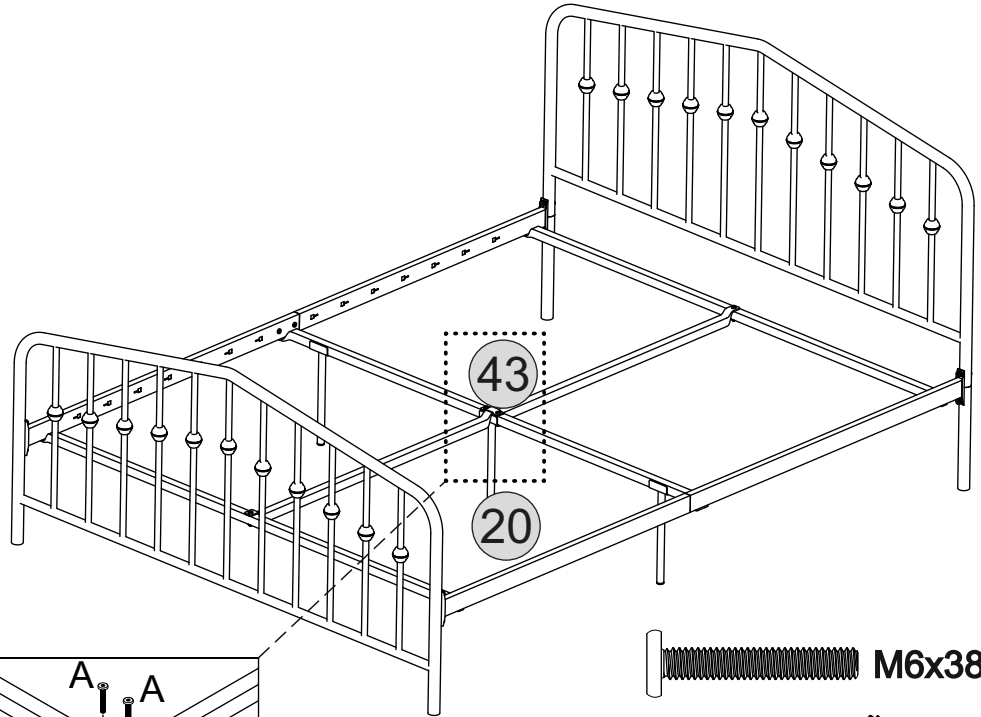
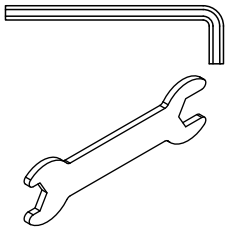

STEP 8

PARTS REQUIRED

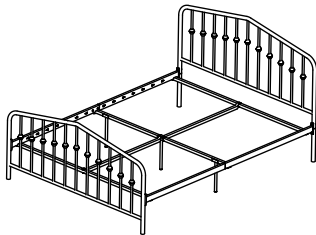

14D - SLATS x14

15 - PLASTIC PLUG x28

HARDWARE REQUIRED

TOOLS REQUIRED

